

NOTES:

1. MATERIALS AND FINISHES (PLATING THICKNESS IN MICRO-INCHES):  
 SHELL - BRASS, NICKEL PLATING  
 CHAIN - BRASS, NICKEL PLATING  
 INSULATOR - PTFE
2. ELECTRICAL:  
 A. FREQUENCY RANGE: DC 0-300 Hz  
 B. DIELECTRIC WITHSTANDING VOLTAGE: 1000 VRMS, MIN.
3. MECHANICAL:  
 A. DURABILITY: 500 CYCLES MIN.  
 B. TEMPERATURE RANGE: - 65°C to +165°C

THIRD ANGLE PROJ.

REVISIONS

REV	DESCRIPTION	DATE	ECO	APPR
A	U1005A1-N WAS N1005A1\TONY. T\02-07-95'	07-Feb-95	---	---
B	DRAWING NO. WERE CHANGED ON ITEM 2 AND NO.3	23-Sep-96	---	TONY
C	SEE SHEET 1	30-Mar-99	---	---
D	SEE SHEET 1	08-Dec-04	---	SH
E	REDRAWN TO UPDATE FORMAT	09-Jul-08	---	SHE

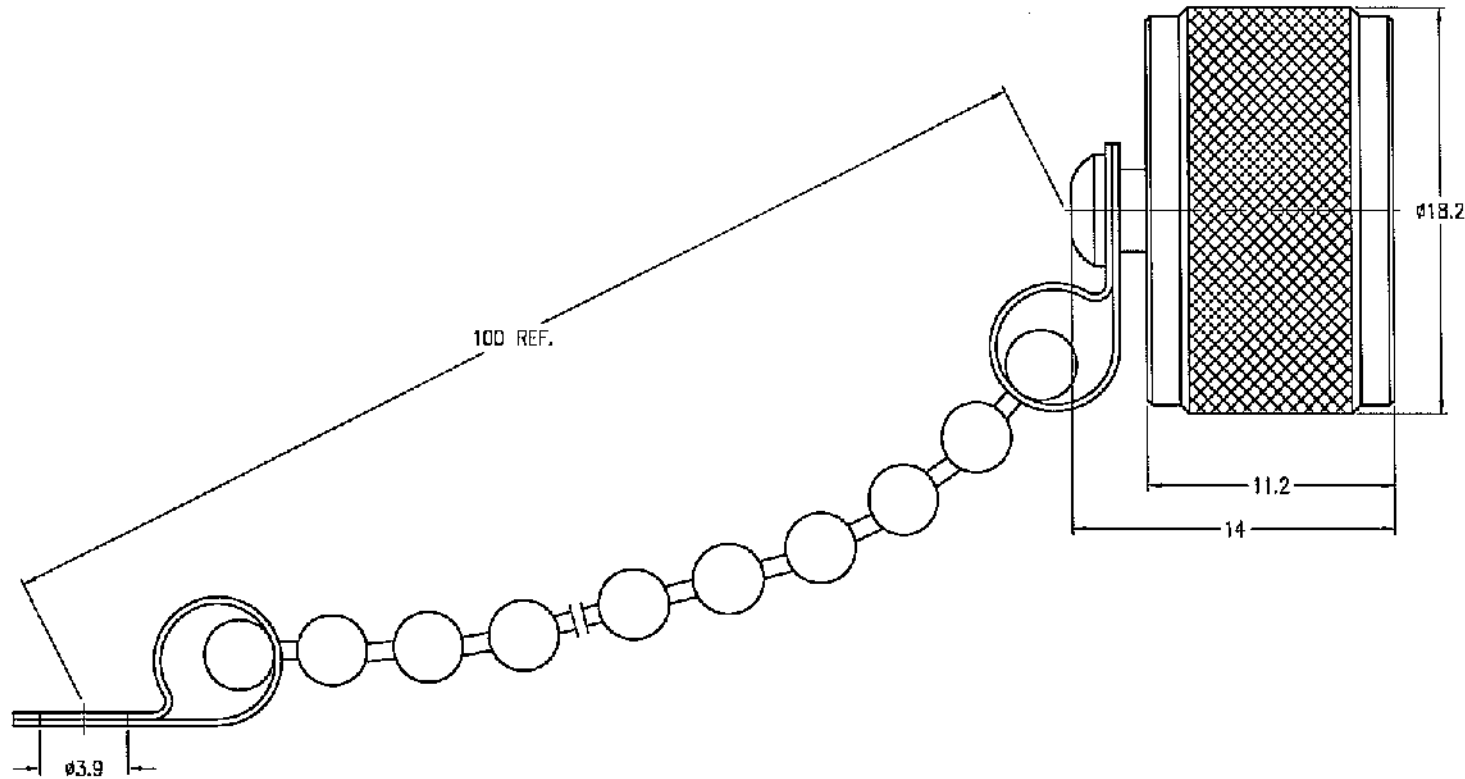

**CUSTOMER OUTLINE DRAWING**

ALL OTHER SHEETS ARE FOR INTERNAL USE ONLY

UNLESS OTHERWISE SPECIFIED, DIMENSIONS ARE IN METRIC AND TOLERANCES ARE:  
 0.5 - 6mm ±0.1mm    6 - 30mm ±0.2mm    30 - 120mm ±0.3mm    ANGLES ±1°

NOTICE - These drawings, specifications, or other data (1) are, and remain the property of Amphenol Corp. (2) must be returned upon request; and (3) are confidential and not to be disclosed to any person other than those to whom they are given by Amphenol Corp. The furnishing of these drawings, specifications, or other data by Amphenol Corp., or to any other person to anyone for any purpose is not to be regarded by implication or otherwise in any manner licensing, granting rights or permitting such holder or any other person to manufacture, use or sell any product, process or design, patented or otherwise, that may in any way be related to or disclosed by said drawings, specifications, or other data.

MATERIAL	DRAWN	DATE	TITLE			Amphenol RF Danbury CT USA, Taichung Taiwan, Shenzhen China www.amphenolrf.com
	AFSUN	15-Dec-04	UHF MALE CAP WITH CHAIN			
REFERENCE	ENGINEER	DATE	SCALE: 3/1	SHEET 2 OF 2	DRAWING NO. U1005A1-N	
	S.HSIEH	15-Dec-04			ITEM NO. 061005AAADONHOF	
FINISH	APPROVED	DATE	DWG SIZE	CODE ID	REV	PART NO. 083-1AC-RFX
	S.HSIEH	15-Dec-04	B	74868	E	
	CAD FILE	F:\DWG\U\1005A1\N-CSZ				