

# GN 927.4 | Cam clamping levers

Zinc alloy and stainless steel



- 1
- 2
- 3
- 4
- 5
- 6
- 7
- 8
- 9
- 10
- 11
- 12
- 13
- 14
- 15
- 16
- 17
- 18

## LEVER BODY

Die-cast zinc alloy, epoxy resin coating, RAL 9005 black colour, matte finish.

## ROTATING PIN

AISI 303 stainless steel.

## CLAMPING ELEMENT

AISI 303 stainless steel with threaded hole or threaded screw.

## STANDARD EXECUTIONS

- **GN 927.4-A-B**: positioning with AISI 303 stainless steel threaded adjustment wing nut, with AISI 303 stainless steel support bushing with glass fibre reinforced acetal-based technopolymer (POM) contact insert.
- **GN 927.4-B-B**: positioning without adjustment wing nut, with support bushing in glass-fibre reinforced polyamide based (PA) technopolymer.

## FEATURES AND APPLICATIONS

GN 927.4 cam clamping levers are suitable for quick clamping. The GN 927.4-A-B version with adjustment wing nut provides quick and efficient tightening. In fact, the adjustment wing nut at the base enables adjustment of the tightening force used and simultaneous locking of the lever in the position required. This type of lever allows you to reach clamping forces up to 8 kN.

## SPECIAL EXECUTIONS ON REQUEST

Lever body in RAL 2004 orange, RAL 3000 red or RAL 9006 grey colour.

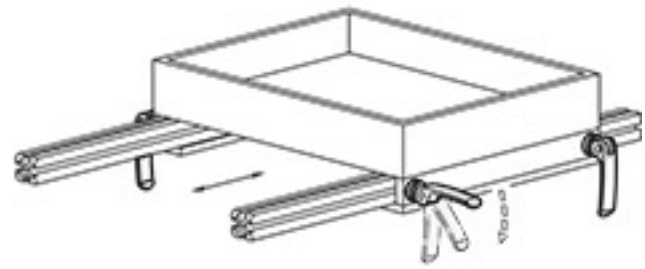
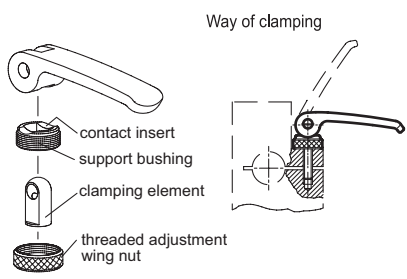

Clamping handles

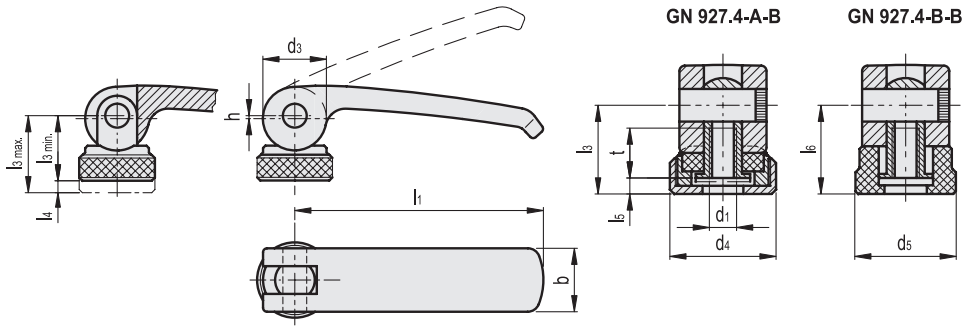

GN 927.4 (d1)

INOX STAINLESS STEEL

Code	Description	l1	d1	l3 min	l3 max	l4	l5	l6	h	d3	d4	d5	t	b	⚖
GN.35791	GN 927.4-44-M4-A-B	44	M4	13.2	15.2	2	2.2	-	0.5	12	15	-	8	12	27
GN.35811	GN 927.4-44-M5-A-B	44	M5	13.2	15.2	2	2.2	-	0.5	12	15	-	8	12	27
GN.35792	GN 927.4-44-M4-B-B	44	M4	-	-	2	2.2	15.2	0.5	12	-	14	8	12	24
GN.35812	GN 927.4-44-M5-B-B	44	M5	-	-	2	2.2	15.2	0.5	12	-	14	8	12	24
GN.68998	GN 927.4-63-M5-A-B	63	M5	16.3	18.8	2.5	3	-	0.75	16	19	-	10	16	57
GN.69001	GN 927.4-63-M6-A-B	63	M6	16.3	18.8	2.5	3	-	0.75	16	19	-	10	16	56
GN.68999	GN 927.4-63-M5-B-B	63	M5	-	-	2.5	3	16.3	0.75	16	-	18.5	10	16	51
GN.69002	GN 927.4-63-M6-B-B	63	M6	-	-	2.5	3	16.3	0.75	16	-	18.5	10	16	50
GN.69028	GN 927.4-82-M6-A-B	82	M6	19.5	22.5	3	3.7	-	1	20	25	-	12	20	55
GN.69031	GN 927.4-82-M8-A-B	82	M8	19.5	22.5	3	3.7	-	1	20	25	-	12	20	110
GN.69029	GN 927.4-82-M6-B-B	82	M6	-	-	3	3.7	19.5	1	20	-	22.5	12	20	60
GN.69032	GN 927.4-82-M8-B-B	82	M8	-	-	3	3.7	19.5	1	20	-	22.5	12	20	97
GN.69058	GN 927.4-101-M8-A-B	101	M8	25.3	29.3	4	4.8	-	1.5	26	30	-	15	25	215
GN.69061	GN 927.4-101-M10-A-B	101	M10	25.3	29.3	4	4.8	-	1.5	26	30	-	15	25	211
GN.69059	GN 927.4-101-M8-B-B	101	M8	-	-	4	4.8	25.3	1.5	26	-	27	15	25	200
GN.69062	GN 927.4-101-M10-B-B	101	M10	-	-	4	4.8	25.3	1.5	26	-	27	15	25	185

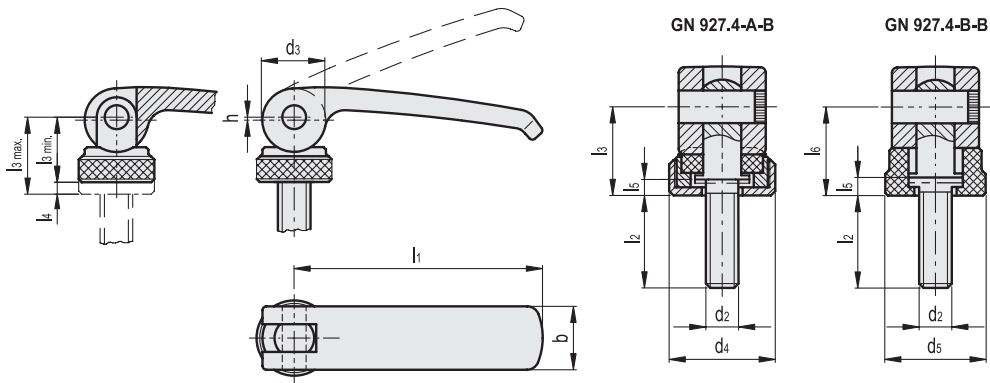

GN 927.4 (d2 - l2)

INOX STAINLESS STEEL

Code	Description	l1	d2	l2	l3 min	l3 max	l4	l5	l6	h	d3	d4	d5	b	⚖
GN.35796	GN 927.4-44-M4-12-A-B	44	M4	12	13.2	15.2	2	2.2	-	0.5	12	15	-	12	29
GN.35798	GN 927.4-44-M4-16-A-B	44	M4	16	13.2	15.2	2	2.2	-	0.5	12	15	-	12	29
GN.35800	GN 927.4-44-M4-20-A-B	44	M4	20	13.2	15.2	2	2.2	-	0.5	12	15	-	12	28
GN.35802	GN 927.4-44-M4-25-A-B	44	M4	25	13.2	15.2	2	2.2	-	0.5	12	15	-	12	30
GN.35804	GN 927.4-44-M4-30-A-B	44	M4	30	13.2	15.2	2	2.2	-	0.5	12	15	-	12	30
GN.35816	GN 927.4-44-M5-12-A-B	44	M5	12	13.2	15.2	2	2.2	-	0.5	12	15	-	12	28
GN.35818	GN 927.4-44-M5-16-A-B	44	M5	16	13.2	15.2	2	2.2	-	0.5	12	15	-	12	30
GN.35820	GN 927.4-44-M5-20-A-B	44	M5	20	13.2	15.2	2	2.2	-	0.5	12	15	-	12	32
GN.35822	GN 927.4-44-M5-25-A-B	44	M5	25	13.2	15.2	2	2.2	-	0.5	12	15	-	12	32
GN.35824	GN 927.4-44-M5-30-A-B	44	M5	30	13.2	15.2	2	2.2	-	0.5	12	15	-	12	32
GN.35826	GN 927.4-44-M5-35-A-B	44	M5	35	13.2	15.2	2	2.2	-	0.5	12	15	-	12	30
GN.35828	GN 927.4-44-M5-40-A-B	44	M5	40	13.2	15.2	2	2.2	-	0.5	12	15	-	12	32



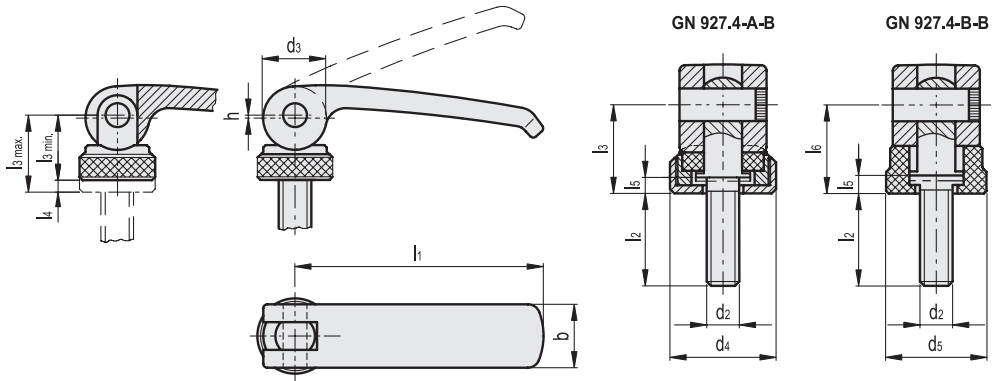

GN 927.4 (d2 - l2)

Code	Description	l1	d2	l2	l3 min	l3 max	l4	l5	l6	h	d3	d4	d5	b	⚖
GN.35797	GN 927.4-44-M4-12-B-B	44	M4	12	-	-	2	2.2	15.2	0.5	12	-	14	12	25
GN.35799	GN 927.4-44-M4-16-B-B	44	M4	16	-	-	2	2.2	15.2	0.5	12	-	14	12	26
GN.35801	GN 927.4-44-M4-20-B-B	44	M4	20	-	-	2	2.2	15.2	0.5	12	-	14	12	25
GN.35803	GN 927.4-44-M4-25-B-B	44	M4	25	-	-	2	2.2	15.2	0.5	12	-	14	12	26
GN.35805	GN 927.4-44-M4-30-B-B	44	M4	30	-	-	2	2.2	15.2	0.5	12	-	14	12	27
GN.35817	GN 927.4-44-M5-12-B-B	44	M5	12	-	-	2	2.2	15.2	0.5	12	-	14	12	24
GN.35819	GN 927.4-44-M5-16-B-B	44	M5	16	-	-	2	2.2	15.2	0.5	12	-	14	12	27
GN.35821	GN 927.4-44-M5-20-B-B	44	M5	20	-	-	2	2.2	15.2	0.5	12	-	14	12	29
GN.35823	GN 927.4-44-M5-25-B-B	44	M5	25	-	-	2	2.2	15.2	0.5	12	-	14	12	29
GN.35825	GN 927.4-44-M5-30-B-B	44	M5	30	-	-	2	2.2	15.2	0.5	12	-	14	12	29
GN.35827	GN 927.4-44-M5-35-B-B	44	M5	35	-	-	2	2.2	15.2	0.5	12	-	14	12	31
GN.35829	GN 927.4-44-M5-40-B-B	44	M5	40	-	-	2	2.2	15.2	0.5	12	-	14	12	29
GN.35836	GN 927.4-63-M5-16-A-B	63	M5	16	16.3	18.8	2.5	3	-	0.75	16	19	-	16	60
GN.68996	GN 927.4-63-M5-20-A-B	63	M5	20	16.3	18.8	2.5	3	-	0.75	16	19	-	16	55
GN.69023	GN 927.4-63-M5-25-A-B	63	M5	25	16.3	18.8	2.5	3	-	0.75	16	19	-	16	56
GN.69005	GN 927.4-63-M5-30-A-B	63	M5	30	16.3	18.8	2.5	3	-	0.75	16	19	-	16	61
GN.69025	GN 927.4-63-M5-35-A-B	63	M5	35	16.3	18.8	2.5	3	-	0.75	16	19	-	16	62
GN.69027	GN 927.4-63-M5-40-A-B	63	M5	40	16.3	18.8	2.5	3	-	0.75	16	19	-	16	63
GN.69009	GN 927.4-63-M5-50-A-B	63	M5	50	16.3	18.8	2.5	3	-	0.75	16	19	-	16	65
GN.35840	GN 927.4-63-M6-16-A-B	63	M6	16	16.3	18.8	2.5	3	-	0.75	16	19	-	16	60
GN.69011	GN 927.4-63-M6-20-A-B	63	M6	20	16.3	18.8	2.5	3	-	0.75	16	19	-	16	62
GN.69013	GN 927.4-63-M6-25-A-B	63	M6	25	16.3	18.8	2.5	3	-	0.75	16	19	-	16	63
GN.69015	GN 927.4-63-M6-30-A-B	63	M6	30	16.3	18.8	2.5	3	-	0.75	16	19	-	16	63
GN.69017	GN 927.4-63-M6-35-A-B	63	M6	35	16.3	18.8	2.5	3	-	0.75	16	19	-	16	64
GN.69019	GN 927.4-63-M6-40-A-B	63	M6	40	16.3	18.8	2.5	3	-	0.75	16	19	-	16	65
GN.69021	GN 927.4-63-M6-50-A-B	63	M6	50	16.3	18.8	2.5	3	-	0.75	16	19	-	16	68
GN.35838	GN 927.4-63-M5-16-B-B	63	M5	16	-	-	2.5	3	16.3	0.75	16	-	18.5	16	55
GN.68997	GN 927.4-63-M5-20-B-B	63	M5	20	-	-	2.5	3	16.3	0.75	16	-	18.5	16	55
GN.69024	GN 927.4-63-M5-25-B-B	63	M5	25	-	-	2.5	3	16.3	0.75	16	-	18.5	16	56
GN.69006	GN 927.4-63-M5-30-B-B	63	M5	30	-	-	2.5	3	16.3	0.75	16	-	18.5	16	56
GN.69026	GN 927.4-63-M5-35-B-B	63	M5	35	-	-	2.5	3	16.3	0.75	16	-	18.5	16	62
GN.69008	GN 927.4-63-M5-40-B-B	63	M5	40	-	-	2.5	3	16.3	0.75	16	-	18.5	16	65
GN.69010	GN 927.4-63-M5-50-B-B	63	M5	50	-	-	2.5	3	16.3	0.75	16	-	18.5	16	65
GN.35842	GN 927.4-63-M6-16-B-B	63	M6	16	-	-	2.5	3	16.3	0.75	16	-	18.5	16	54
GN.69012	GN 927.4-63-M6-20-B-B	63	M6	20	-	-	2.5	3	16.3	0.75	16	-	18.5	16	62
GN.69014	GN 927.4-63-M6-25-B-B	63	M6	25	-	-	2.5	3	16.3	0.75	16	-	18.5	16	63
GN.69016	GN 927.4-63-M6-30-B-B	63	M6	30	-	-	2.5	3	16.3	0.75	16	-	18.5	16	63
GN.69018	GN 927.4-63-M6-35-B-B	63	M6	35	-	-	2.5	3	16.3	0.75	16	-	18.5	16	64
GN.69020	GN 927.4-63-M6-40-B-B	63	M6	40	-	-	2.5	3	16.3	0.75	16	-	18.5	16	63
GN.69022	GN 927.4-63-M6-50-B-B	63	M6	50	-	-	2.5	3	16.3	0.75	16	-	18.5	16	68

## GN 927.4 (d2 - l2)

INOX STAINLESS STEEL

Code	Description	l1	d2	l2	l3 min	l3 max	l4	l5	l6	h	d3	d4	d5	b	⚖
GN.35856	GN 927.4-82-M6-20-A-B	82	M6	20	19.5	22.5	3	3.7	-	1	20	25	-	20	118
GN.69033	GN 927.4-82-M6-25-A-B	82	M6	25	19.5	22.5	3	3.7	-	1	20	25	-	20	120
GN.69035	GN 927.4-82-M6-30-A-B	82	M6	30	19.5	22.5	3	3.7	-	1	20	25	-	20	120
GN.69037	GN 927.4-82-M6-35-A-B	82	M6	35	19.5	22.5	3	3.7	-	1	20	25	-	20	120
GN.69039	GN 927.4-82-M6-40-A-B	82	M6	40	19.5	22.5	3	3.7	-	1	20	25	-	20	120
GN.69053	GN 927.4-82-M6-50-A-B	82	M6	50	19.5	22.5	3	3.7	-	1	20	25	-	20	122
GN.69055	GN 927.4-82-M6-60-A-B	82	M6	60	19.5	22.5	3	3.7	-	1	20	25	-	20	122
GN.35860	GN 927.4-82-M8-20-A-B	82	M8	20	19.5	22.5	3	3.7	-	1	20	25	-	20	121
GN.69041	GN 927.4-82-M8-25-A-B	82	M8	25	19.5	22.5	3	3.7	-	1	20	25	-	20	122
GN.69043	GN 927.4-82-M8-30-A-B	82	M8	30	19.5	22.5	3	3.7	-	1	20	25	-	20	123
GN.69045	GN 927.4-82-M8-35-A-B	82	M8	35	19.5	22.5	3	3.7	-	1	20	25	-	20	125
GN.69047	GN 927.4-82-M8-40-A-B	82	M8	40	19.5	22.5	3	3.7	-	1	20	25	-	20	129
GN.69049	GN 927.4-82-M8-50-A-B	82	M8	50	19.5	22.5	3	3.7	-	1	20	25	-	20	130
GN.69051	GN 927.4-82-M8-60-A-B	82	M8	60	19.5	22.5	3	3.7	-	1	20	25	-	20	132
GN.35858	GN 927.4-82-M6-20-B-B	82	M6	20	-	-	3	3.7	19.5	1	20	-	22.5	20	103
GN.69034	GN 927.4-82-M6-25-B-B	82	M6	25	-	-	3	3.7	19.5	1	20	-	22.5	20	120
GN.69036	GN 927.4-82-M6-30-B-B	82	M6	30	-	-	3	3.7	19.5	1	20	-	22.5	20	120
GN.69038	GN 927.4-82-M6-35-B-B	82	M6	35	-	-	3	3.7	19.5	1	20	-	22.5	20	120
GN.69040	GN 927.4-82-M6-40-B-B	82	M6	40	-	-	3	3.7	19.5	1	20	-	22.5	20	120
GN.69054	GN 927.4-82-M6-50-B-B	82	M6	50	-	-	3	3.7	19.5	1	20	-	22.5	20	122
GN.69056	GN 927.4-82-M6-60-B-B	82	M6	60	-	-	3	3.7	19.5	1	20	-	22.5	20	122
GN.35862	GN 927.4-82-M8-20-B-B	82	M8	20	-	-	3	3.7	19.5	1	20	-	22.5	20	106
GN.69042	GN 927.4-82-M8-25-B-B	82	M8	25	-	-	3	3.7	19.5	1	20	-	22.5	20	122
GN.69044	GN 927.4-82-M8-30-B-B	82	M8	30	-	-	3	3.7	19.5	1	20	-	22.5	20	123
GN.69046	GN 927.4-82-M8-35-B-B	82	M8	35	-	-	3	3.7	19.5	1	20	-	22.5	20	125
GN.69048	GN 927.4-82-M8-40-B-B	82	M8	40	-	-	3	3.7	19.5	1	20	-	22.5	20	129
GN.69050	GN 927.4-82-M8-50-B-B	82	M8	50	-	-	3	3.7	19.5	1	20	-	22.5	20	130
GN.69052	GN 927.4-82-M8-60-B-B	82	M8	60	-	-	3	3.7	19.5	1	20	-	22.5	20	132
GN.69063	GN 927.4-101-M8-20-A-B	101	M8	20	25.3	29.3	4	4.8	-	1.5	26	30	-	25	224
GN.69065	GN 927.4-101-M8-30-A-B	101	M8	30	25.3	29.3	4	4.8	-	1.5	26	30	-	25	227
GN.69067	GN 927.4-101-M8-40-A-B	101	M8	40	25.3	29.3	4	4.8	-	1.5	26	30	-	25	232
GN.69069	GN 927.4-101-M8-50-A-B	101	M8	50	25.3	29.3	4	4.8	-	1.5	26	30	-	25	235
GN.69081	GN 927.4-101-M8-60-A-B	101	M8	60	25.3	29.3	4	4.8	-	1.5	26	30	-	25	238
GN.69071	GN 927.4-101-M10-20-A-B	101	M10	20	25.3	29.3	4	4.8	-	1.5	26	30	-	25	229
GN.35866	GN 927.4-101-M10-25-A-B	101	M10	25	25.3	29.3	4	4.8	-	1.5	26	30	-	25	232
GN.69073	GN 927.4-101-M10-30-A-B	101	M10	30	25.3	29.3	4	4.8	-	1.5	26	30	-	25	234
GN.35870	GN 927.4-101-M10-35-A-B	101	M10	35	25.3	29.3	4	4.8	-	1.5	26	30	-	25	237
GN.69075	GN 927.4-101-M10-40-A-B	101	M10	40	25.3	29.3	4	4.8	-	1.5	26	30	-	25	240
GN.69077	GN 927.4-101-M10-50-A-B	101	M10	50	25.3	29.3	4	4.8	-	1.5	26	30	-	25	260
GN.69079	GN 927.4-101-M10-60-A-B	101	M10	60	25.3	29.3	4	4.8	-	1.5	26	30	-	25	265
GN.69064	GN 927.4-101-M8-20-B-B	101	M8	20	-	-	4	4.8	25.3	1.5	26	-	27	25	224
GN.69066	GN 927.4-101-M8-30-B-B	101	M8	30	-	-	4	4.8	25.3	1.5	26	-	27	25	227
GN.69068	GN 927.4-101-M8-40-B-B	101	M8	40	-	-	4	4.8	25.3	1.5	26	-	27	25	232
GN.69070	GN 927.4-101-M8-50-B-B	101	M8	50	-	-	4	4.8	25.3	1.5	26	-	27	25	235
GN.69082	GN 927.4-101-M8-60-B-B	101	M8	60	-	-	4	4.8	25.3	1.5	26	-	27	25	238
GN.69072	GN 927.4-101-M10-20-B-B	101	M10	20	-	-	4	4.8	25.3	1.5	26	-	27	25	229
GN.35868	GN 927.4-101-M10-25-B-B	101	M10	25	-	-	4	4.8	25.3	1.5	26	-	27	25	184
GN.69074	GN 927.4-101-M10-30-B-B	101	M10	30	-	-	4	4.8	25.3	1.5	26	-	27	25	234
GN.35872	GN 927.4-101-M10-35-B-B	101	M10	35	-	-	4	4.8	25.3	1.5	26	-	27	25	220
GN.69076	GN 927.4-101-M10-40-B-B	101	M10	40	-	-	4	4.8	25.3	1.5	26	-	27	25	240
GN.69078	GN 927.4-101-M10-50-B-B	101	M10	50	-	-	4	4.8	25.3	1.5	26	-	27	25	260
GN.69080	GN 927.4-101-M10-60-B-B	101	M10	60	-	-	4	4.8	25.3	1.5	26	-	27	25	265



Clamping handles