

BPS SERIES

006004
Issue 1

Battery Safety Pressure Sensors CAN Communication Output

DESCRIPTION

The BPS Series are automotive-grade pressure sensors designed to detect and report thermal runaway events in lithium-ion battery packs. They use a combination of MEMS (Micro- Electromechanical System) and ASIC (Application-Specific Integrated Circuit) technologies to detect pressure changes in the battery packs of electric vehicles and energy storage systems (ESS). The detected value is transmitted to the battery management system (BMS) using CAN (Controller Area Network) communication.

The BPS Series measures from 50 kPa to 300 kPa absolute pressure. It has settable warning thresholds for both absolute pressure and rate of change of pressure. The BPS Series allows early detection of a thermal runaway event in a lithium-ion battery pack. This product delivers on performance and reliability.

The BPS Series is automotive qualified and incorporates integrated circuits that are AEC-Q100 qualified to meet higher quality and reliability requirements. The BPS series is also RoHS compliant.

CUSTOMIZATION

The BPS Series may be customized to better meet application needs. Solutions may be tailored to exact specifications for improved time to market, lower total system costs and enhanced reliability. For technical assistance, we provide global engineering and service support for your needs.

OPERATING MODES

The sensors function in the following operating modes:

- **ECO Mode:** The sensor operates in ECO mode when the request pin voltage is set to low. The sensor wakes up for 15 ms and hibernates for the remaining 985 ms (typical) to reduce power consumption during each measurement cycle of 1 second (default value). In ECO Mode, CAN communication is disabled. If the absolute pressure or rate of change of pressure is above the set threshold, a wake-up signal is sent to the BMS to initiate a full battery system check.
- **Continuous Mode:** The sensor operates in Continuous Mode when the request pin voltage is set to high by the BMS. CAN communication is enabled in Continuous mode. In Continuous mode, the sensor monitors and outputs the absolute pressure and rate of change of pressure to the BMS using CAN communication. The sensor can be switched to ECO mode by setting the request pin voltage to low.

Note: The sensor default working mode is ECO mode.

WORKING LOGIC FUNCTIONS

- **Request Signal :** The BMS controls the sensor's operating mode through the request pin of the sensor.
- **Wake-up Signal:** When the sensor detects that the absolute pressure or rate of change of pressure is above a set threshold, the wake-up pin is set to high to wake up the BMS.

TRANSPORTATION APPLICATIONS

- Battery pack systems for electric vehicles and energy



FEATURES

- High accuracy and low temperature drift
- CAN communication protocol
- Wake-up output and request input for high reliability system integration
- Settable warning thresholds for absolute pressure and rate of change of pressure allow use with different equipment types

VALUE TO CUSTOMERS

- Early detection of thermal runaway has the potential to mitigate the loss of life and property
- ECO mode enables continuous system monitoring in low power mode
- Thermal runaway detection sensor allows compliance with international regulations and recommendations
- Solutions may be tailored to exact specifications for improved time to market
- Lower total system costs and enhanced reliability



The BPS Series joins the Battery Monitoring Suite. To view the entire product portfolio, [click here.](#)

Honeywell

BATTERY SAFETY PRESSURE SENSORS

1.0 GENERAL SPECIFICATIONS

TABLE 1. GENERAL SPECIFICATIONS¹

CHARACTERISTIC	MIN.	TYP.	MAX.	UNIT	CONDITION
Operating and storage temperature ranges	-40 [-40]	—	105 [221]	°C [°F]	—
Absolute pressure detection range	50	—	300	kPa	—
Maximum withstand pressure	—	—	400	kPa	—
Maximum failure pressure	—	—	500	kPa	—

¹ All specifications are at room temperature unless otherwise noted.

2.0 CAN (CONTROLLER AREA NETWORK) OUTPUT

The BPS Series is able to provide outputs using the CAN communication protocol. See Table 2 for additional information.

TABLE 2. OPERATING SPECIFICATIONS FOR CAN VERSIONS¹

CHARACTERISTIC	MIN.	TYP.	MAX.	UNIT	CONDITION
CANBUS protocol	—	—	—	—	Version 2.0A/B
Baud rate	—	—	500	kbps	—
Supply voltage (Vs)	6	12	18	V	—
Over voltage	—	—	24	V	for Vs, 1 min at 25°C
Reverse voltage	—	—	-20	V	for Vs, 1 min at 25°C
Supply current	—	25	30	mA	Continuous Mode
ECO mode current:					
t = 1 s	—	—	200	µA	1 s ECO Mode cycle time
t = 2 s	—	—	100	µA	2 s ECO Mode cycle time
Wake-up output:					
high level voltage	5.5	12	18	V	—
low level voltage	—	—	0.15	V	—
output capability	0.6	1.2	1.8	mA	—
default state (low level voltage)	—	—	0.15	V	—
REQUEST input from from BMS to BPS:					
voltage	5.5	12	18	V	—
sink current	—	—	0.15	mA	—
enable voltage level	5.5	12	18	V	—
disable voltage level	—	—	0.5	V	—
enable signal time	—	50	—	ms	—
Minimum data bit (resolution)	0.1	—	—	kPa	-40°C to 105°C
Absolute accuracy:					
10°C to 100°C	-2	—	2	kPa	—
-40°C to 105°C	-4	—	4	kPa	—
ECO Mode detection cycle time	400	1000	2000	ms	ECO Mode, configurable
Response time	—	30	—	ms	—

¹ All specifications are at room temperature unless otherwise noted.

BMS: BATTERY MANAGEMENT SYSTEM

TABLE 3. ORDER GUIDE

CATALOG LISTING	DESCRIPTION
BPS6C-X00	BPS Series, battery safety pressure sensor, six pins, CAN output signal, MCU1 version.
BPS6C-H00	BPS Series, battery safety pressure sensor, six pins, CAN output signal, MCU2 version.

NOTE: MCU1 is a drop-in replacement for MCU2. No change to product fit, form and function. The MCU options improve material supply.

BATTERY SAFETY PRESSURE SENSORS

3.0 SENSOR OVERVIEW

Figure 1. State Diagram

The BPS Series has two operating modes: ECO mode and Continuous mode. The state diagram below describes these operating modes and the transition between the modes.

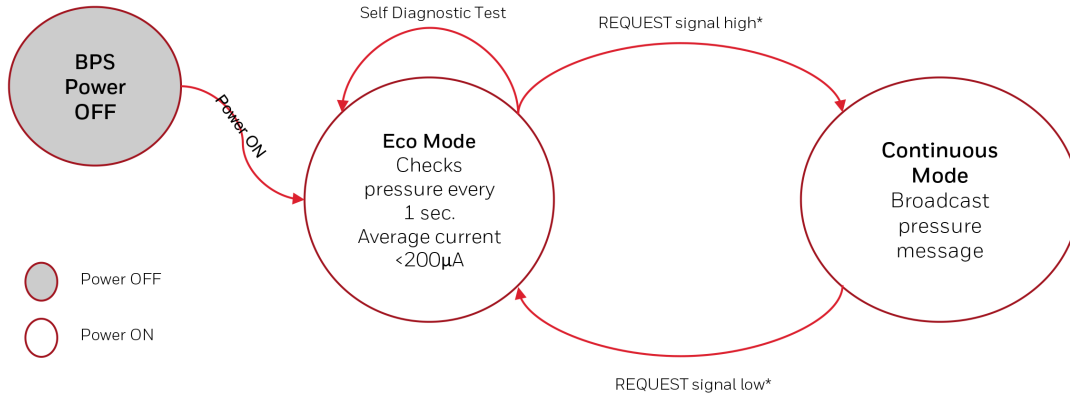

NOTE: * The state of the REQUEST signal is determined by the BMS. See figure 2.

Figure 2. BPS and BMS Signal Interface

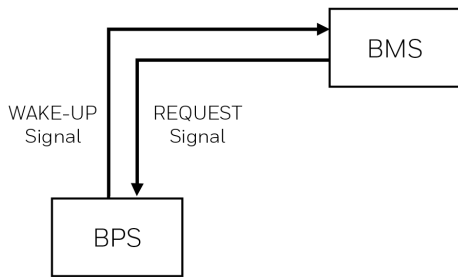
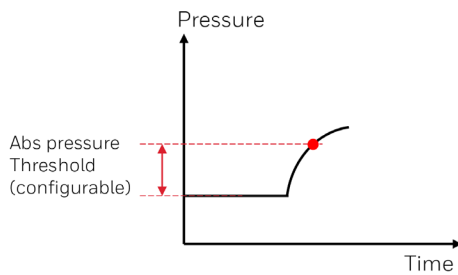
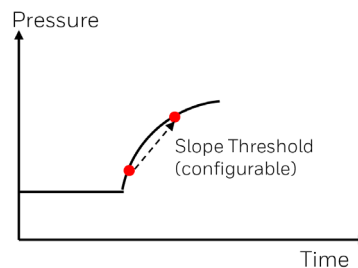

Figure 3. Absolute Pressure Sensing



The absolute pressure is the air pressure in the battery pack. The absolute pressure settable warning threshold can be configured. When the air pressure in the battery pack is greater than the absolute pressure threshold, the BPS flags this event. Refer to Installation Instructions for more information.

Figure 4. Rate of Change (Slope) Threshold Monitoring



The rate of change of absolute pressure is monitored in the battery pack. The rate of change (slope) threshold can be configured. When the rate of change of air pressure in the battery pack is greater than the slope threshold, the BPS flags this event. Refer to Installation Instructions for more information.

BATTERY SAFETY PRESSURE SENSORS

SCHEMATIC DIAGRAMS AND OUTPUT SIGNALS

Figure 5. Recommended REQUEST pin BMS interface circuit

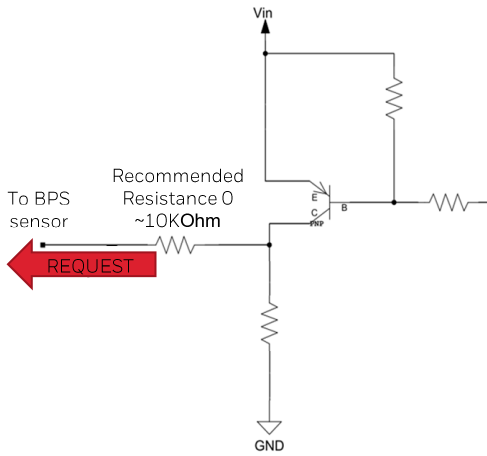

DEFAULT STATE: ACTIVE LOW

TABLE 4. BMS REQUEST INPUT

PARAMETER	MIN.	TYP.	MAX.	UNIT
BMS request input voltage	5.5	12	18	V
Sink current	—	—	0.15	mA
Request enable voltage level	5.5	12	18	V
Request disable voltage level	—	—	0.5	V
Request enable signal time	—	50	—	ms

Figure 6. Recommended WAKEUP pin interface circuit

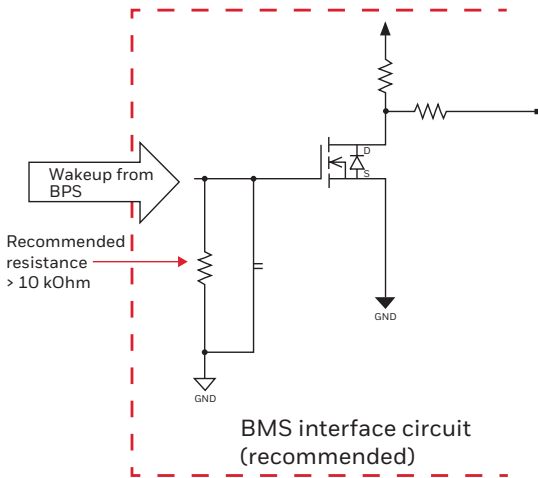

TABLE 5. WAKEUP OUTPUT

PARAMETER	MIN.	TYP.	MAX.	UNIT
Wakeup high level voltage	5.5	12	18	V
Wakeup low level voltage	—	—	0.5	V
Wakeup output capability	0.6	1.2	1.8	mA
Default state (Low level voltage)	—	—	0.5	V

BATTERY SAFETY PRESSURE SENSORS

Figure 7. Product Nomenclature

For example, **BPS6C-X00** defines a BPS Series, battery safety pressure sensor, six pins, CAN output signal, MCU1 version.

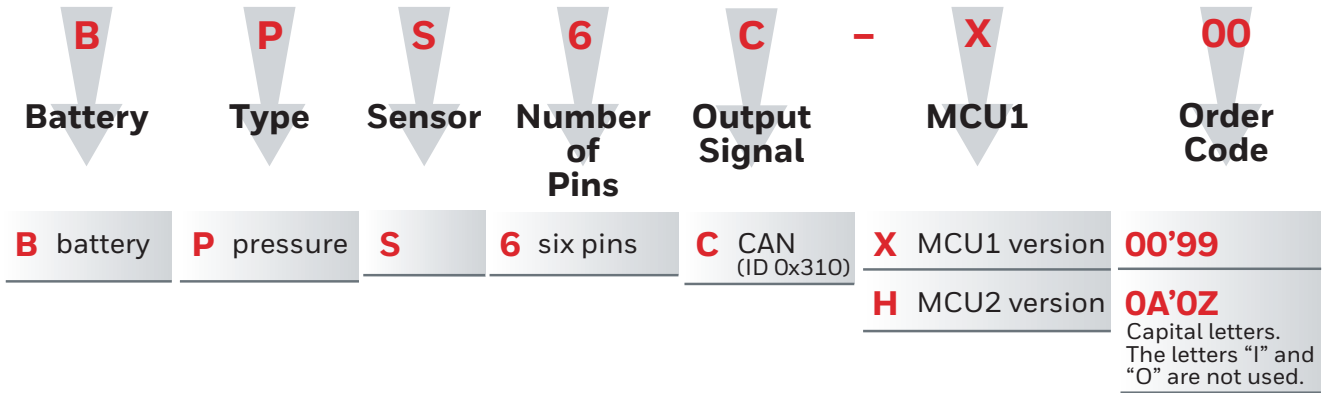

Figure 8. Mounting Dimensions (For reference only)

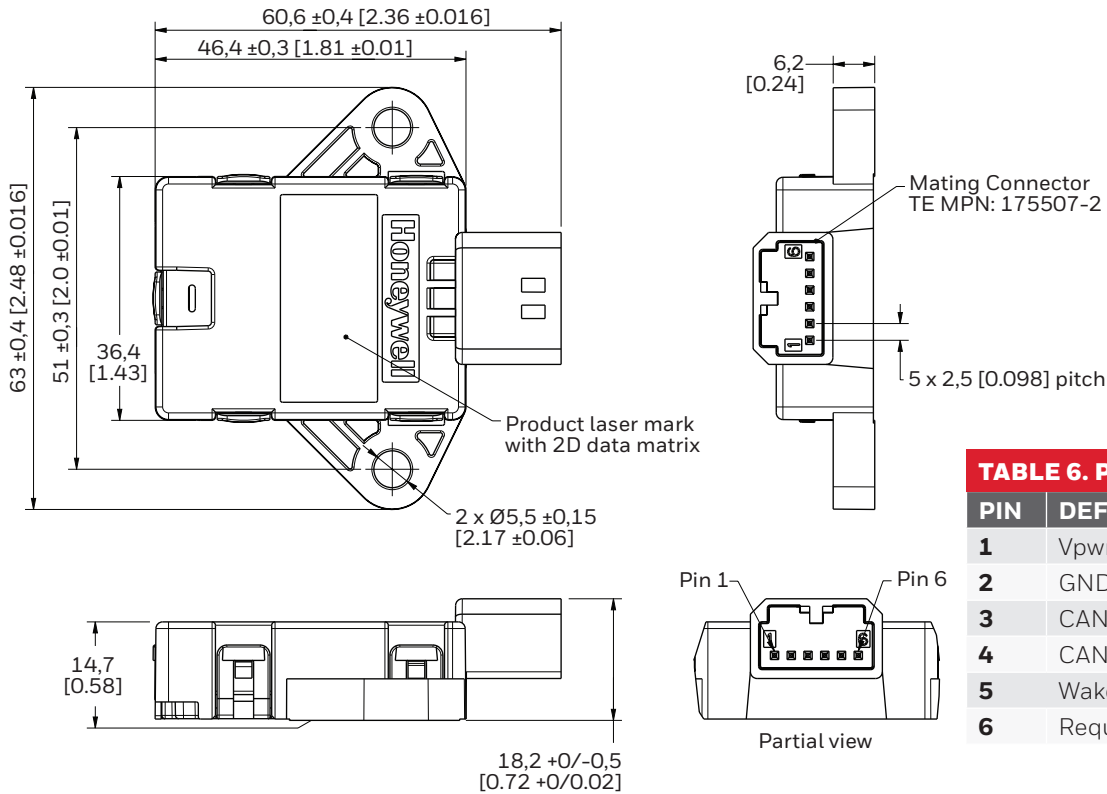
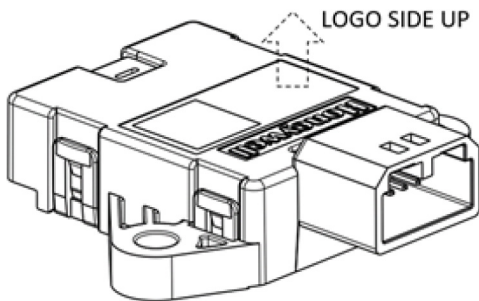

TABLE 6. PINOUT	
PIN	DEFINITION
1	Vpwr
2	GND
3	CAN_H
4	CAN_L
5	Wakeup
6	Request

Figure 9. Sensor Installation Recommendation



WARRANTY/REMEDY

Honeywell warrants goods of its manufacture as being free of defective materials and faulty workmanship during the applicable warranty period. Honeywell's standard product warranty applies unless agreed to otherwise by Honeywell in writing; please refer to your order acknowledgment or consult your local sales office for specific warranty details. If warranted goods are returned to Honeywell during the period of coverage, Honeywell will repair or replace, at its option, without charge those items that Honeywell, in its sole discretion, finds defective.

The foregoing is buyer's sole remedy and is in lieu of all other warranties, expressed or implied, including those of merchantability and fitness for a particular purpose. In no event shall Honeywell be liable for consequential, special, or indirect damages.

While Honeywell may provide application assistance personally, through our literature and the Honeywell web site, it is buyer's sole responsibility to determine the suitability of the product in the application.

Specifications may change without notice. The information we supply is believed to be accurate and reliable as of this writing. However, Honeywell assumes no responsibility for its use.

FOR MORE INFORMATION

Honeywell Sensing and Safety Technologies services its customers through a worldwide network of sales offices and distributors. For application assistance, current specifications, pricing or the nearest Authorized Distributor, visit our [website](#) or call:

USA/Canada	+1 302 613 4491
Latin America	+1 305 805 8188
Europe	+44 1344 238258
Japan	+81 (0) 3-6730-7152
Singapore	+65 6355 2828
Greater China	+86 4006396841

Honeywell Sensing and Safety Technologies

830 East Arapaho Road
Richardson, TX 75081
sps.honeywell.com/ast

WARNING PERSONAL INJURY

DO NOT USE these products as safety or emergency stop devices or in any other application where failure of the product could result in personal injury.

Failure to comply with these instructions could result in death or serious injury.

WARNING MISUSE OF DOCUMENTATION

- The information presented in this product sheet is for reference only. Do not use this document as a product installation guide.
- Complete installation, operation, and maintenance information is provided in the instructions supplied with each product.

Failure to comply with these instructions could result in death or serious injury.