



Ultrasonic sensor

UGC00800EOKG/US



1 LEDs



Product characteristics

Electrical design	PNP
Output function	normally open / normally closed; (parameterisable)
Sensing range [mm]	60...800; (Target: 200 x 200 mm)
Housing	threaded type
Dimensions [mm]	M18 x 1 / L = 60.5

Electrical data

Operating voltage [V]	10...30 DC; ("supply class 2" to cULus)
Current consumption [mA]	< 35
Protection class	III
Reverse polarity protection	yes
Power-on delay time [s]	< 0.3
Converter frequency [kHz]	230

Inputs / outputs

Number of inputs and outputs	Number of digital outputs: 1
------------------------------	------------------------------

Inputs

Synchronisation input	no
Multiplex input	no

Outputs

Total number of outputs	1
Electrical design	PNP
Number of digital outputs	1
Output function	normally open / normally closed; (parameterisable)
Max. voltage drop switching output DC [V]	2.2
Permanent current rating of switching output DC [mA]	100
Switching frequency DC [Hz]	5
Short-circuit protection	yes
Overload protection	yes

UGT201



Ultrasonic sensor

UGC00800EOKG/US

Detection zone		
Sensing range	[mm]	60...800; (Target: 200 x 200 mm)
Blind zone	[mm]	60
Angle of aperture cylindrical	[°]	15; (±2)
Max. deviation from the 90° angle sensor/object	[°]	± 4
Accuracy / deviations		
Temperature compensation		yes
Hysteresis	[%]	< 1
Switch point drift	[%]	-5...5
Notes on the accuracy / deviation		The indicated values are reached after a warm-up time of min. 20 minutes
Repeatability		1 %
Resolution	[mm]	3
Operating conditions		
Ambient temperature	[°C]	-20...70
Storage temperature	[°C]	-30...80
Protection		IP 67
Tests / approvals		
EMC	EN 61000-4-2 ESD	4 kV CD / 8 kV AD
	EN 61000-4-3 HF radiated	3 V/m
	EN 61000-4-4 Burst	2 kV
	EN 61000-4-6 HF conducted	3 V
	EN 55011	Class A
Vibration resistance	EN 60068-2-6 Fc	(10-55) Hz 1 mm amplitude, oscillation period 5 min., 30 min. per axis at resonance or 55 Hz
Shock resistance	EN 60068-2-27 Ea	30 g 11 ms half-sine; 3 shocks each in every direction of the 3 coordinate axes
MTTF	[years]	235
UL approval	Ta	-20...70 °C
	voltage supply	Class 2
	File number UL	E174191
Mechanical data		
Weight	[g]	56
Housing		threaded type
Dimensions	[mm]	M18 x 1 / L = 60.5
Thread designation		M18 x 1
Materials		PBT; PA; epoxy glass ceramics
Tightening torque	[Nm]	1
Displays / operating elements		
Display	switching status	1 x LED, yellow
	echo	1 x LED, green
Accessories		
Accessories (supplied)		lock nuts: 2, plastics rubber washers: 2



Ultrasonic sensor

UGC00800EOKG/US

Remarks

Remarks	operating voltage "supply class 2" according to cULus
Pack quantity	1 pcs.

Electrical connection

Connector: 1 x M12



Connection

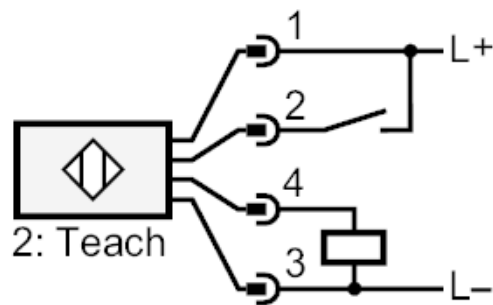

2: Teach

Diagrams and graphs

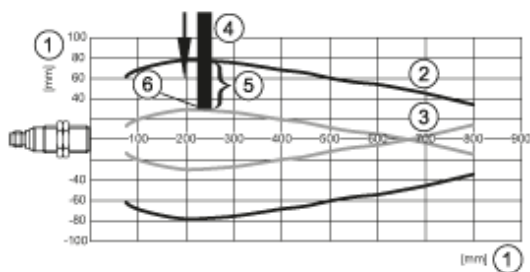
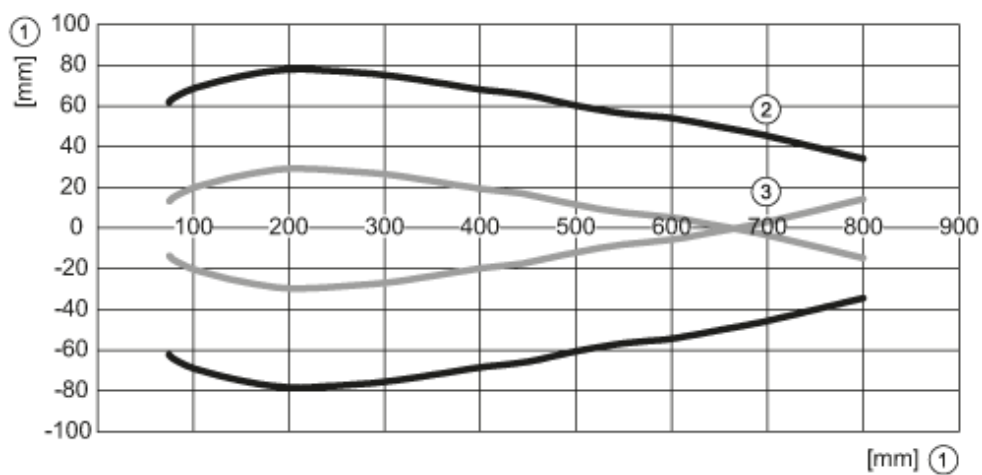

- 1: distance
- 2: Detection zone
- 3: switch-on/switch-off graph
- 4: Target 100 x 100 mm
- 5: 50% of the target in the detection zone
- 6: switch point