

Micro-tek

Micro-Shear[®] flush cutters utilize a shearing cut, with the by-pass cutting edges slicing cleanly through the metal.

9100AS

Oval Head Micro-Shear[®] Flush Cutter - ESD safe
 Strong and Durable. Size and shape reflect the latest advances in enhanced ergonomics.
 Cutting edges are an ultra durable 56-58 RC.
 Cutting capacity: 12 AWG (2.0 mm) soft wire.

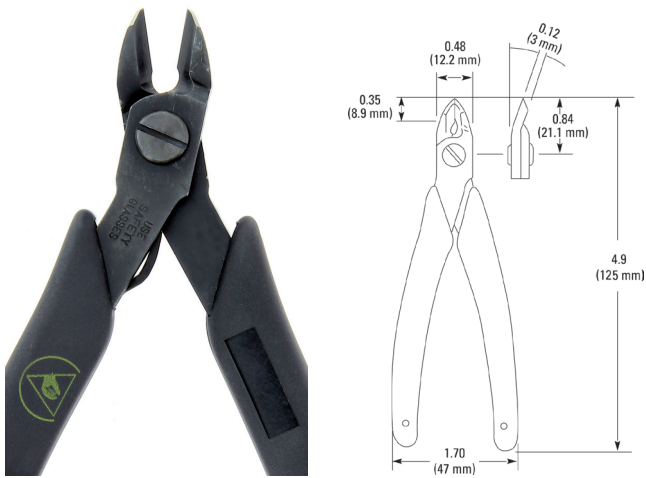

9200AS

Tapered Head Micro-Shear[®] Flush Cutter - ESD safe
 Tapered Head version of 9100AS. Improved access in high density areas and added precision.
 Precision-ground Micro-Shear[®] cutting edges guarantee a clean cut.
 Cutting capacity: 14 AWG (1.6 mm) soft wire.

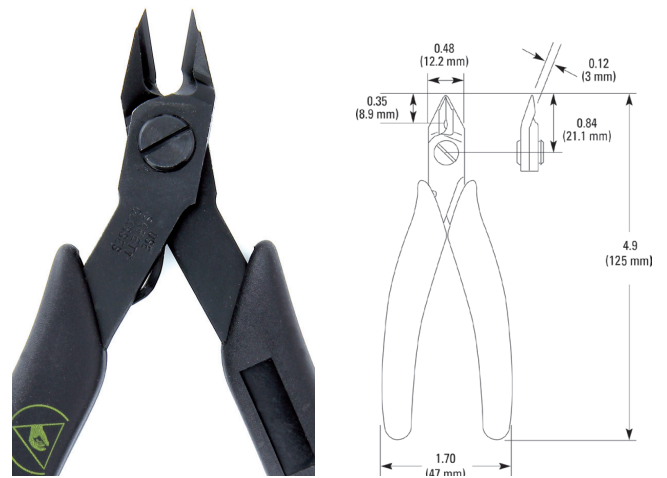

410AS

Micro-Shear[®] Flush Cutter - ESD safe
 Size and shape are optimized to work in high density areas.
 Rockwell hardness of 55-57 RC.
 Cutting capacity: 18 AWG (1.02 mm) soft wire.

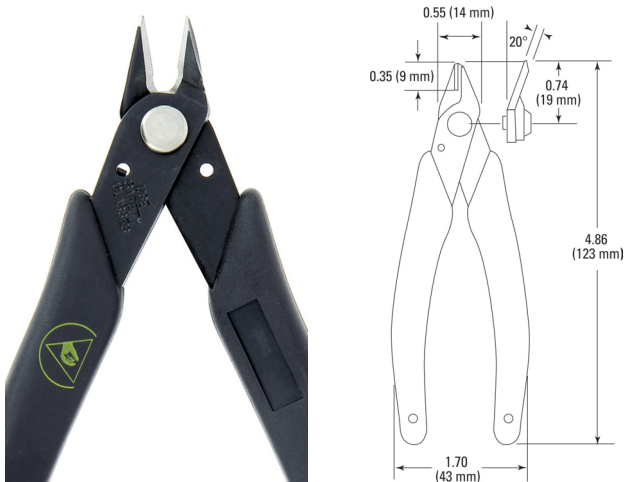

420AS

Angled Micro-Shear[®] Flush Cutter - ESD safe
 Slim profile for accessibility allows easier cutting in difficult areas.
 Angled head provides excellent sight lines when used in either the vertical or horizontal position.
 Cutting capacity: 20 AWG (0.8 mm) soft wire.

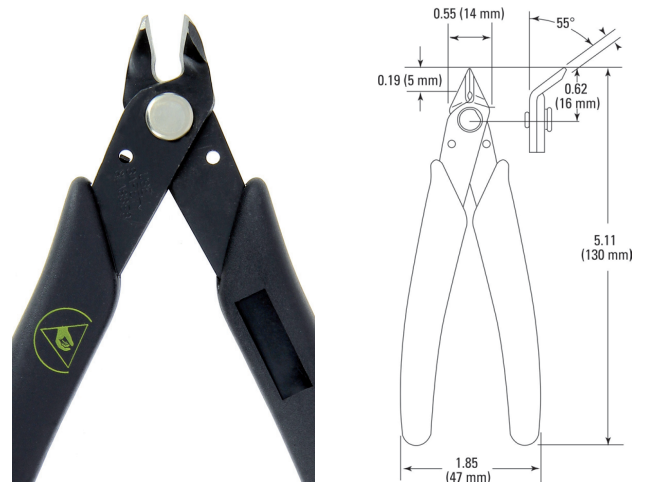

2175AS

Maxi-Shear™ Flush Cutter - ESD safe

Extremely durable and versatile wire cutter.

Tough enough for harnesses and cables with the precision to cut material less than 1 mm thick or work in high density areas.

Cutting capacity: 12 AWG (2.0 mm) soft wire.

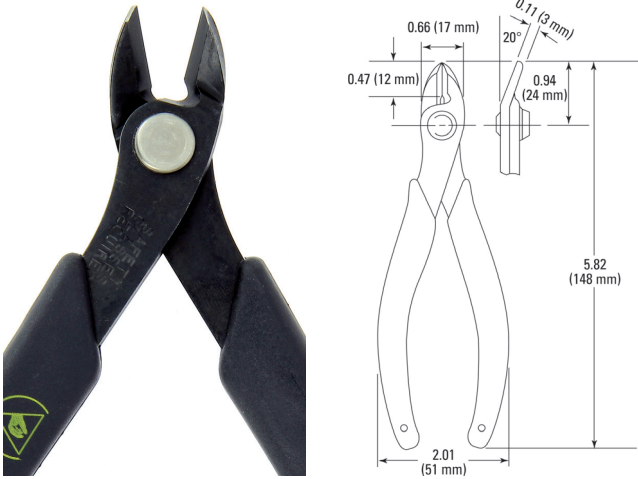

2193AS

Music Wire Shear - ESD safe

Designed specifically for cutting music wire and other types of hardened wire.

Used to cut hardened and tempered steel wire up to 12 AWG.

Cuts music wire up to 0.040" (1.0 mm) diameter.

Cutting capacity: 12 AWG (2.0 mm) hard wire.

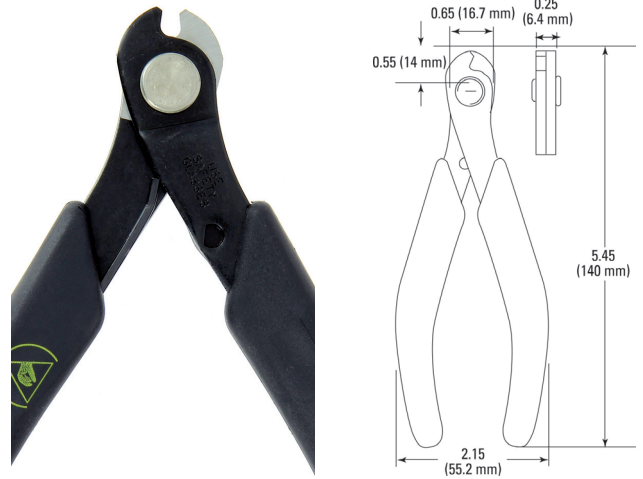

Micro Cutter

LXAS

Micro-Shear® Flush Cutter - ESD safe

Ultra slim profile for access in high density areas.

Extra tough high carbon steel blades.

Sized for smaller hands and maximum maneuverability.

Cutting capacity: 16 AWG (1.29 mm) soft wire.

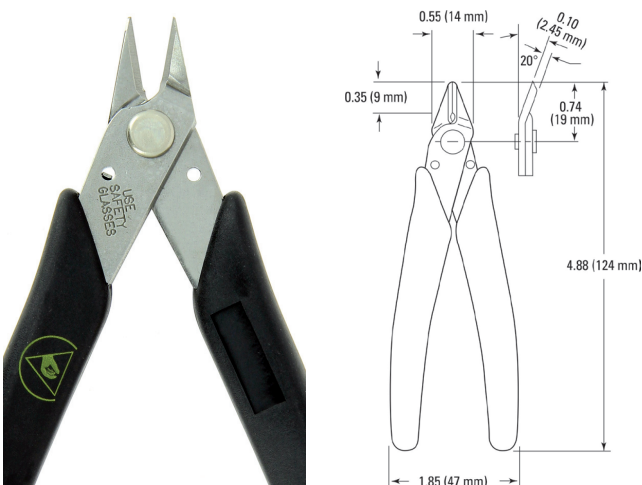

175

Micro-tek Flush Cutter - ESD safe

Carefully crafted precision cutting blades combine seamlessly with curved, palm shaped handles to deliver effortless lead cutting (copper, nickel, etc. up to 1mm) and user comfort.

Hardened carbon steel, thin profile for tight areas.

Cutting capacity: 18 AWG (1.02 mm) soft wire.



Scissors

440AS

Mini-Shear - ESD safe

Ultra precise scissor, cuts fine or delicate items with a clean, square edge.

Innovative design, advantageous for users with arthritic hands.

Cutting capacity: 20 AWG (0.8 mm) soft wire.
0.005" (0.127 mm) mylar, plastic and shielded cable.

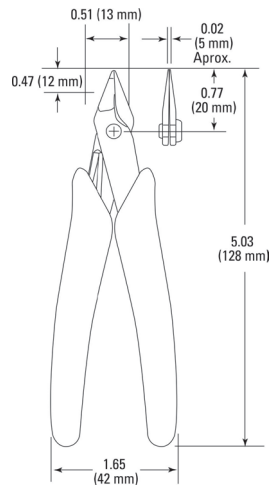

9180AS

Kevlar® Fiber Shear - ESD safe

Designed and manufactured specifically for cutting the Kevlar® fiber strength component of fiber optic cables.

Serrated edge prevents the fibers from sliding out the front of the shear while cutting. Cutting edges 58-60 RC.

Cutting capacity: 12 AWG (2.0 mm) soft wire.

030" (0.8 mm) soft sheet metal.

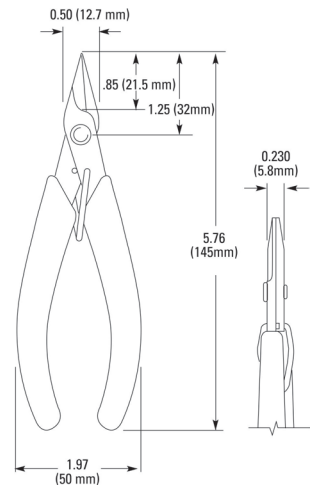

Wire Stripper

501AS

Wire Stripper/Cutter - ESD safe

Designed to cut and strip all wire sizes from 10-26 AWG.

Can be used for both solid and stranded wire.

Cutting capacity: 10-26 AWG (2.59-0.405 mm) stranded wire.

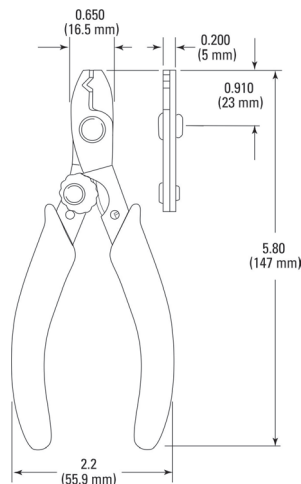

505AS

Wire Stripper/Cutter - ESD safe

Similar to 501AS, but with the added benefit of having wire gauge markings on the cam and a handy closure "hook" that keeps the tool in a closed position when not in use.

Model 505AS is designed for solid wire from 12-26 AWG (2.0-0.405 mm).

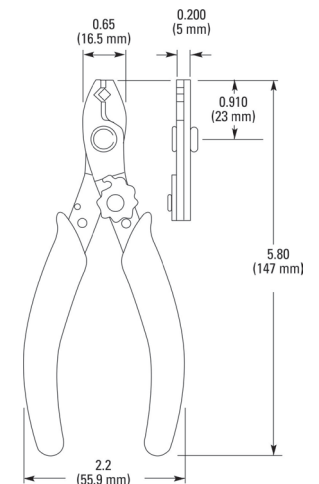

Jewellery Crimper

494 - Four in One Crimper

A bead crimping plier that precisely crimps/folds 1, 2, and 3 millimeter crimp tubes and includes a chain nose plier for handling delicate beads, micro-crimps and for adding an extra squeeze to your crimps.

The folding stations are designed to fit three different size crimp tubes (1, 2 & 3 mm) and ensure a secure and attractive result. Crimper has soft rubber hand grips and a return spring that opens the tool after each squeeze.

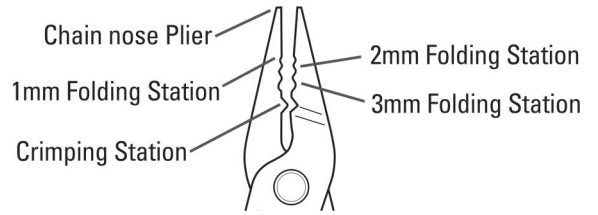

Step #1
Place crimp in the Crimping Station. Squeeze firmly.

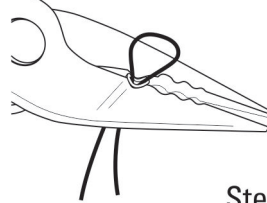

Step #2
Turn crimp on its side. < Place in the appropriate size Folding Station. Squeeze firmly.

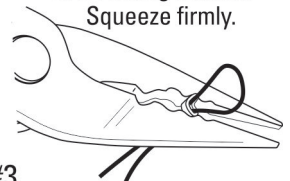

Step #3

Use the chain nose tip of the plier for any additional squeezing or bending.

Split Ring Plier

496

Designed for performance and ease of use, the split ring plier's curved catch tip opens the ring and securely grasps it, simplifying installation of clasps, charms or other jewelry pieces. Low profile return spring automatically brings tool back to open position after each installation.

