

Product Data Sheet CoR 8212J/2H4P

ebmpapst

The engineer's choice



CoR 8212J/2H4P

INDEX

1	General	3
2	Mechanics	3
2.1	General	3
2.2	Connections	3
3	Operating Data	5
3.1	Electrical Interface - Input	5
3.2	Electrical Operating Data	6
3.3	Electrical Interface - Output	7
3.4	Electrical Features	8
3.5	Aerodynamics	9
3.6	Sound Data	10
4	Environment	10
4.1	General	10
4.2	Climatic Requirements	10
5	Safety	11
5.1	Electrical Safety	11
5.2	Approval Tests	11
6	Reliability	11
6.1	General	11

1 General

Fan type	Axial fan	
Rotating direction looking at rotor	Counterclockwise	
Airflow direction	Air outlet over struts	
Bearing system	Ball bearing	
Mounting position - shaft	Any	

2 Mechanics**2.1 General**

Width	80,0 mm	
Height	80,0 mm	
Depth	80,0 mm	
Mass	0,430 kg	
Housing material	Plastic	
Impeller material	Plastic	
Max. torque when mounted across both mounting flanges Screw size	Wire outlet corner: 50 Ncm Remaining corners: 110 Ncm ISO 4762 - M4 degreased, without an additional brace and without washer	

2.2 Connections

Electrical connection	Wires	
Lead wire length	L = 310 mm	
Tolerance	+ - 10,0 mm	
Wire size (AWG)	22	
Insulation diameter	1,30 mm	

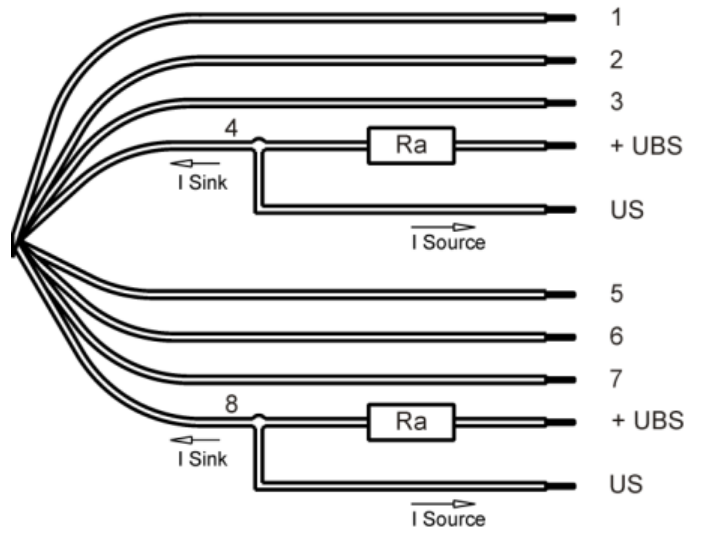

Wire	Color	Operation	Plug connection
1	red	+ UB	Pin 1
2	blue	- GND	Pin 2
3	violet	PWM	Pin 3
4	white	Tacho	Pin 4
5	red	+ UB	Pin 5
6	blue	- GND	Pin 6
7	violet	PWM	Pin 7
8	white	Tacho	Pin 8

3 Operating Data

3.1 Electrical Interface - Input

Control input	PWM
---------------	-----

Features

Input type	Open collector	
PWM - Frequency		1 kHz - 5 kHz

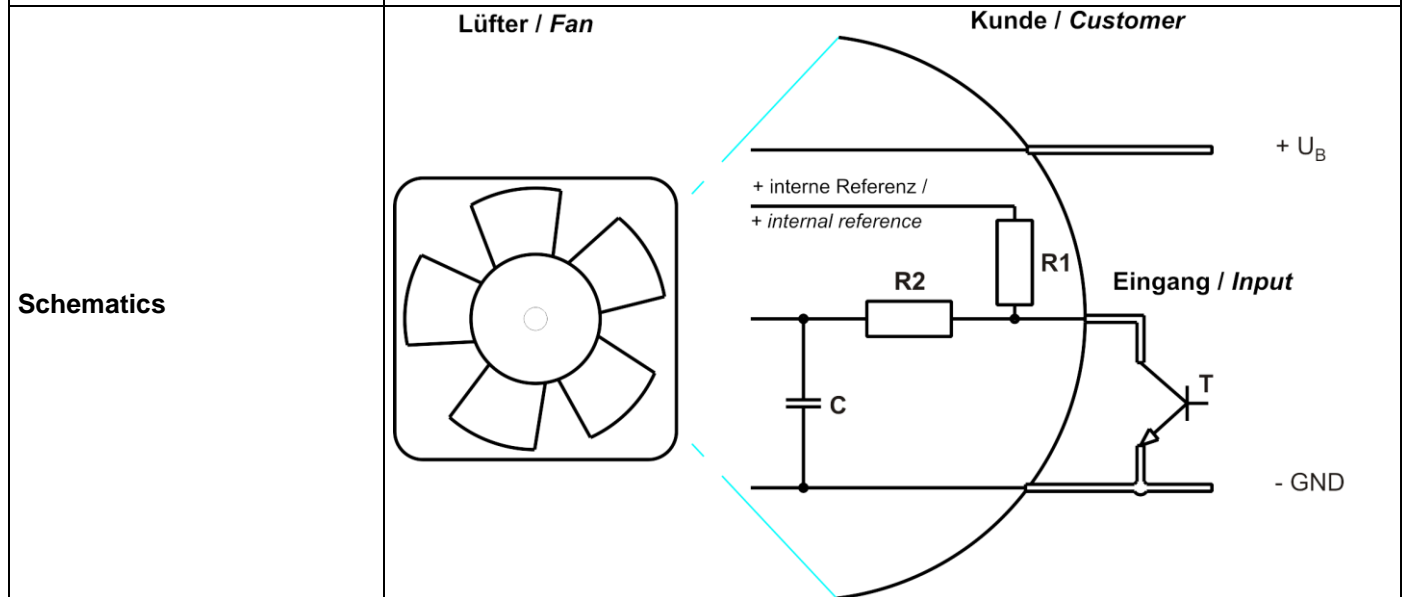
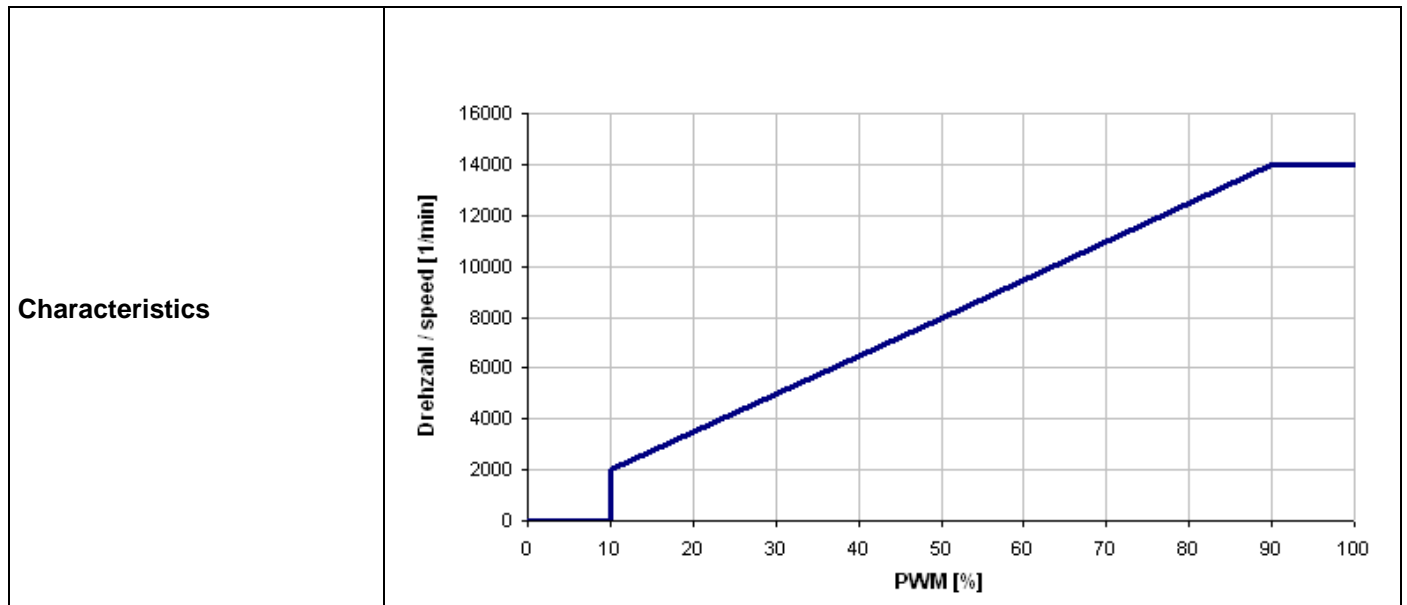

Speed control: 0... 100 %, PWM-Low <0,2 V

3.2 Electrical Operating Data

Measurement conditions: Normal air density = 1,2 kg/m³; Temperature 23°C +/- 3°C; Motor axis horizontal; warm-up time before measuring 5 minutes (unless otherwise specified). In the intake and outlet area should not be any solid obstruction within 0,5 m.

$\Delta p = 0$: corresp. to free air flow (see section 3.5)
 I: corresp. to arithm. mean current value

Name	Condition		
PWM 0001		PWM min.: 90 %; f: 1 kHz	PWM max.: 100 %; f: 5 kHz

Features	Condition	Symbol	Values		
Voltage range		U	6 V		13,8 V
Nominal voltage		U _N		12,0 V	
Power consumption	$\Delta p = 0$	P	16,0 W	70,0 W	71,0 W
Tolerance	PWM 0010		+/- 17,5 %	+/- 17,5 %	+/- 25,0 %
Current consumption	$\Delta p = 0$	I	2.600 mA	5.800 mA	5.100 mA
Tolerance	PWM 0010		+/- 17,5 %	+/- 17,5 %	+/- 25,0 %
Speed	$\Delta p = 0$	n	8.150 1/min	14.000 1/min	14.000 1/min
Tolerance	PWM 0010		+/- 12,5 %	+/- 7,5 %	+/- 3,0 %
Starting current consumption				<= 23.000 mA	

Start-up current characteristic* [5A/div]:

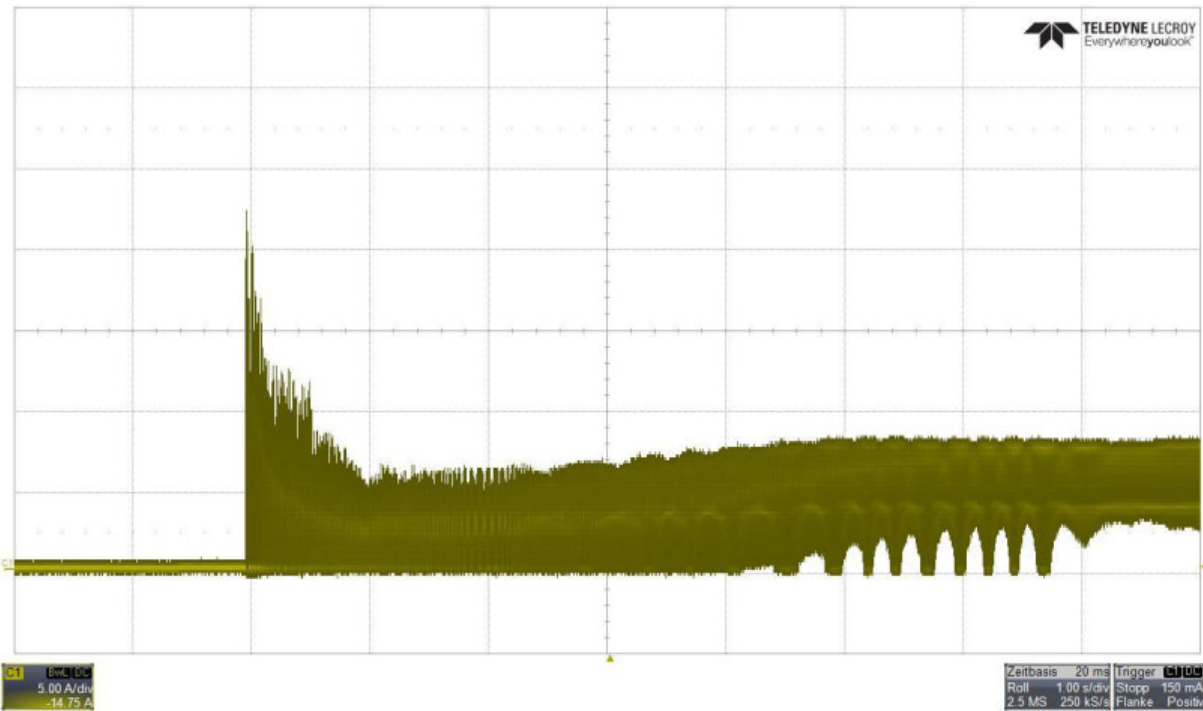

*) Start-up current characteristic may vary depending on how synchronous both fans actually start-up.

3.3 Electrical Interface - Output

Tacho type	/2 (open collector)
------------	---------------------

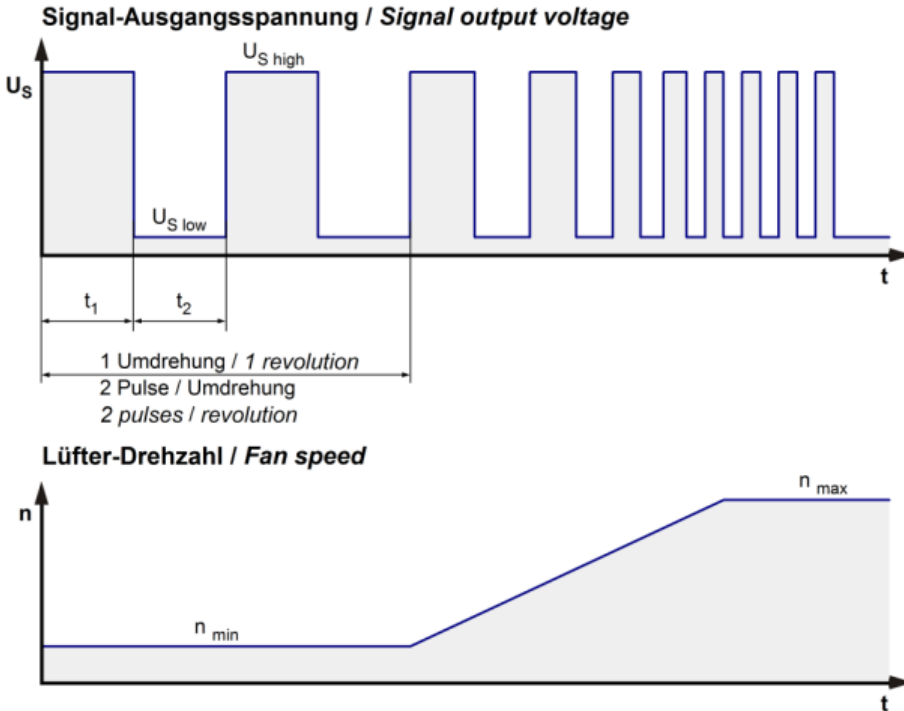

$$R_a = \frac{U_{BS} - U_{S\ low}}{I_{sink}}$$

Lüfter / Fan Kunde / Customer

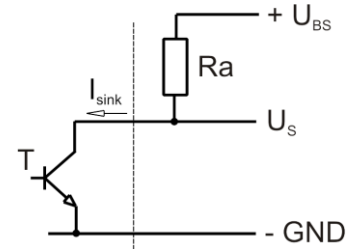

Features	Note	Values
Tacho operating voltage	U_{BS}	$\leq 60,0\ V$
Tacho signal Low	$U_{S\ low}$	$\leq 0,4\ V$ $I_{sink}: 2\ mA$
Tacho signal High	$U_{S\ high}$	$\leq 30,0\ V$ $I_{source}: 0\ mA$
Maximum sink current	I_{sink}	$\leq 4\ mA$
External resistor	External resistor R_a from U_{BS} to U_S required. All voltages measured to GND.	
Tacho frequency	$(2 \times n) / 60$	
Tacho isolated from motor	No	
Slew rate		$\Rightarrow 0,5\ V/\mu s$

n = revolutions per minute (1/min)

3.4 Electrical Features

Electronic function	Speed-Controlled	
Reversed polarity protection Max. residual current at U_N	Rectifying diode $I_F \leq 300 \mu A$	
Locked rotor protection	Auto restart	
Locked rotor current at U_N	I_{block} approx. 11.000 mA	
Clock signal at locked rotor	t_3 / t_4 typical: 0,5 s / 10,0 s	

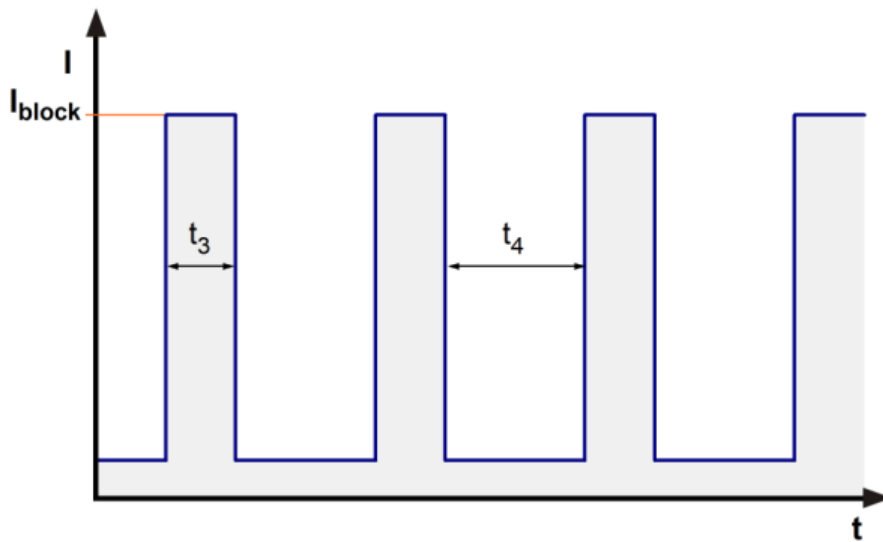

3.5 Aerodynamics

Measurement conditions:

Measured with a double chamber intake rig acc. to DIN EN ISO 5801.
 Normal air density = 1,2 kg/m³; Temperature 23°C +/- 3°C;
 In the intake and outlet area should not be any solid obstruction within 0,5 m.
 The information is only valid under the specified test conditions and may be changed by the installation conditions. If there are deviations from the standard test conditions, the characteristic values must be checked under the installed conditions.

a.) Operation condition:

14.000 1/min at free air flow		PWM min.: 90 %; f: 1 kHz	PWM max.:100 %; f: 5 kHz
Max. free-air flow ($\Delta p = 0 / \dot{V} = \text{max.}$)	237,0 m ³ /h		
Max. static pressure ($\Delta p = \text{max.} / \dot{V} = 0$)	1400 Pa		

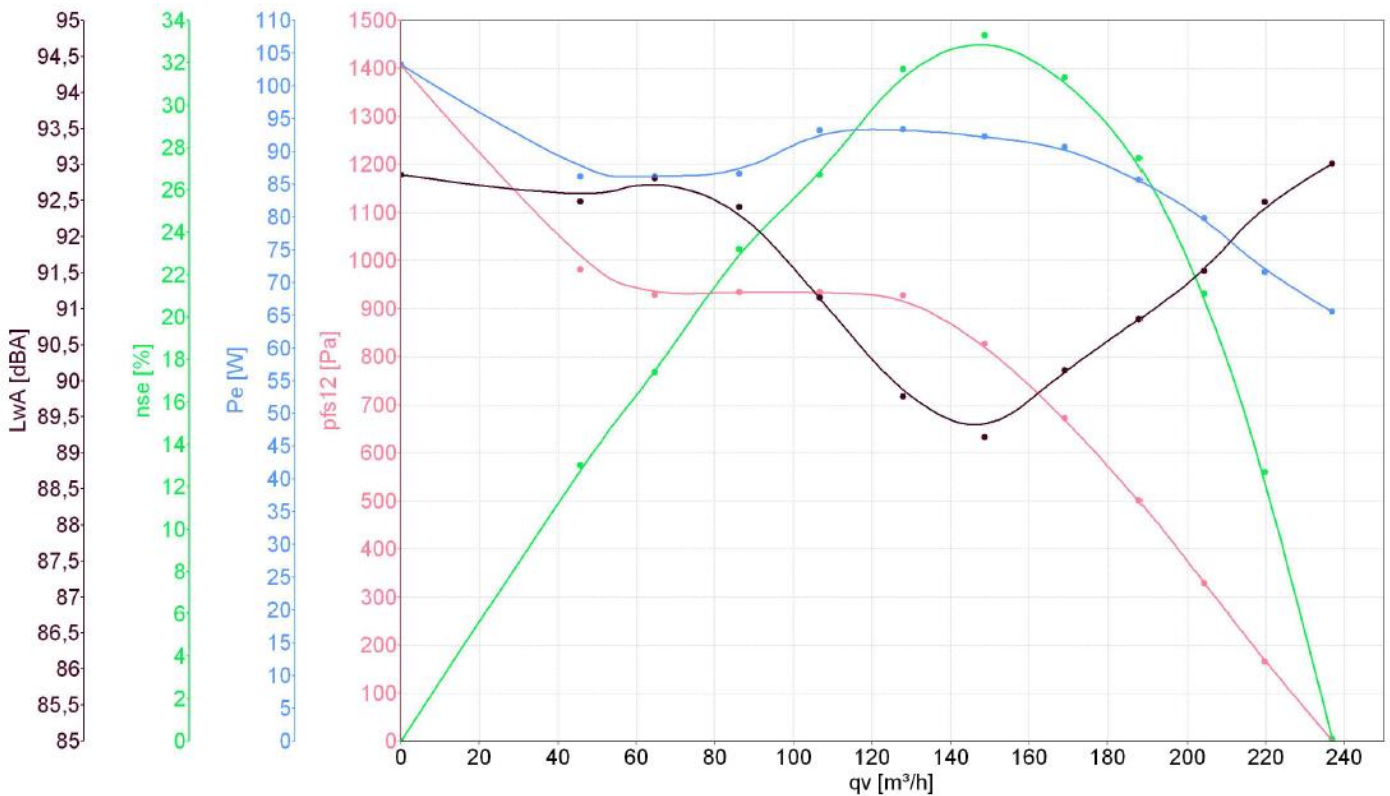

3.6 Sound Data

Measurement conditions: Sound pressure level: 1 meter distance between microphone and the air intake.
 Sound power level: Acc. to DIN 45635 part 38 (ISO 10302)
 Measured in a semianchoic chamber with a background noise level of $L_p(A) < 5 \text{ dB(A)}$
 For further measurement conditions see section 3.5

a.) Operation condition:

14.000 1/min at free air flow		PWM min.: 90 %; f: 1 kHz	PWM max.:100 %; f: 5 kHz
Optimal operating point	147,0 m ³ /h @ 830 Pa		
Sound power level at the optimal operating point	89,4 dB(A)		

4 Environment

4.1 General

Min. permitted ambient temperature TU min.	-20 °C	
Max. permitted ambient temperature TU max.	70 °C	
Min. permitted storage temperature TL min.	-40 °C	
Max. permitted storage temperature TL max.	80 °C	

4.2 Climatic Requirements

Humidity requirements	humid heat, constant; according to DIN EN 60068-2-78, 14 days	
Water exposure	None	
Dust requirements	None	
Salt fog requirements	None	

Permitted application area:

The product is intended for use in sheltered rooms with controlled temperature and controlled humidity. Directly exposure to water must be avoided.

Pollution degree 1 (according DIN EN 60664-1)

There is either no pollution or it occurs only dry, non-conductive pollution. The pollution has no negative impact.

5 Safety

5.1 Electrical Safety

Dielectric strength DIN EN 60950 (VDE 0805) and DIN EN 60335 (VDE 0700) A.) Type test Measuring conditions: After 48h of storage at 95% R.H. and 25°C. No arcing or breakdown is allowed! All connections together to ground.	500 VAC / 1 Min.	
B.) Routine test Measuring conditions: At indoor climate. No arcing or breakdown is allowed! All connections together to ground.	500 VAC / 1 Sec.	
Isolation resistance Measuring conditions: After 48h of storage at 95% R.H. and 25°C measured with U=500 VDC for 1 min.	RI > 10 MOhm	
Clearance / creepage distance	1,0 mm / 1,2 mm	
Protection class	III	

5.2 Approval Tests

CE	EC Declaration of Conformity	Yes
EAC	Eurasian Conformity	Yes
UL	Underwriters Laboratories	Yes / UL507, Electric Fans
VDE	Association for Electrical, Electronic and Information Technologies	Yes / Approval acc. to EN 60950 (VDE 0805) - Information technology equipment
CSA	Canadian Standards Association	Yes / C22.2 No. 113 Fans and Ventilators
CCC	China Compulsory Certification	Not applicable

The approval tests are observed to:
U approval max.:13,2 V @ TU approval max.: 70,0 °C

6 Reliability

6.1 General

Life expectancy L10 at TU = 40 °C	50.000 h	
Life expectancy L10 at TU max.	25.000 h	
Life expectancy L10 acc. to IPC 9591 at TU = 40 °C	85.000 h	

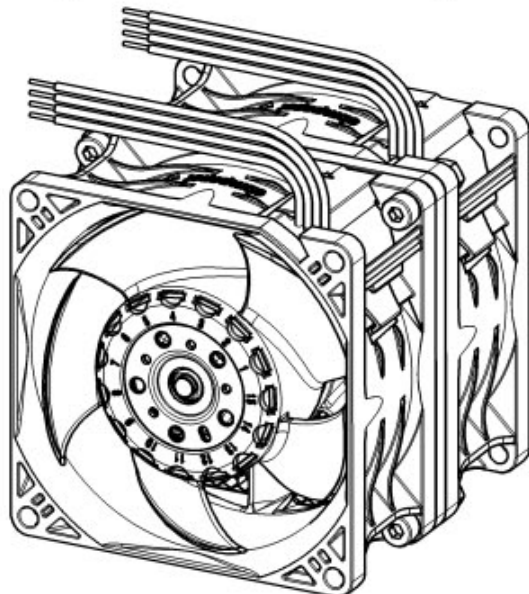
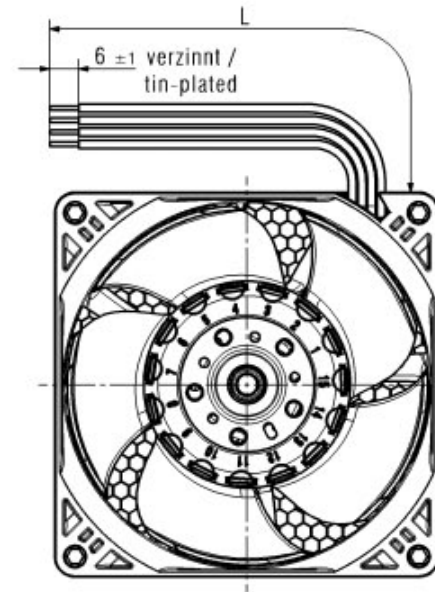
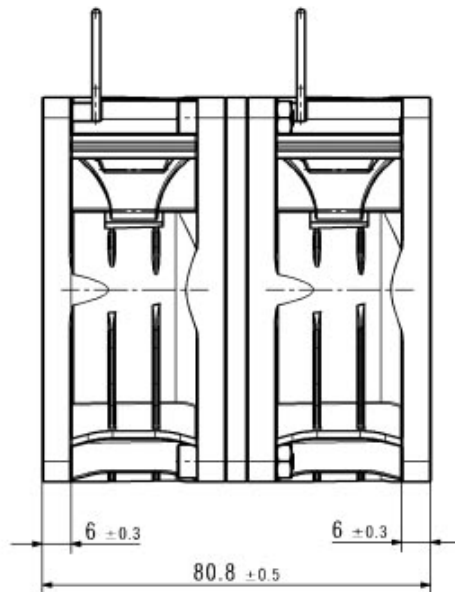
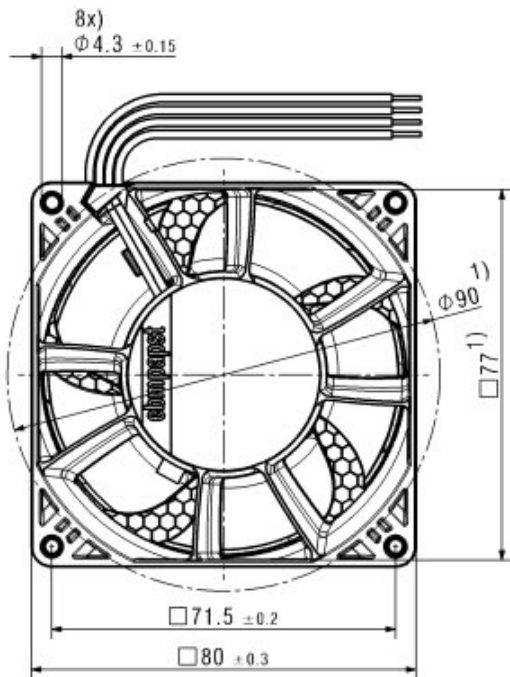

- 1) Maße für Montagewand / Dimensions for assembly wall
 - Kein Axialspiel der Kugellager durch Federausgleich /
 No axial clearance of ball bearings due to a pre-load spring
 - Anzahl und Länge der Litzen siehe Produktspezifikation Blatt 1
 Number and length of the wires see design specification sheet 1

FR		V5824	PAPST	Material / Material:		Volume / Volumen (Liters): 157.685.995	
Document-Status / Document-Status		CAD-Version / CAD-Version		CAD-Geometrie / CAD-Geometrie		Gewicht / Mass (kg):	
3D-Referenzmodell / 3D-Referenzmodell		9972910001 CPH00A		Artikel / Title:			
Toleranz / Tolerances: Size ISO 14405 E		Datum / Date		Lüftereinheit			
Allgemeintoleranz / Gen. Tolerances: DIN ISO 2768-MK		Name / Name		Zug-Nr. / Drawing No:		Ers.-F./Zug. / Replaces:	
Änd.-Nr. / Change No.		04.04.2017		9972910001			
Zeichn. / Drawn		04.04.2017		MAYERS			
Fertig. / Finished		05.04.2017		MAYERS			
Fertig. / Finished		05.04.2017		KWOLINSKI			
ebmpapst		Document-Tag / Type of Document		Teilenummer / (Blatt/Page)		Format / Size:	
www.papst-st.com		C2D		002		A3	
				Index / Index		Maßstab/Scale	
				-		1:1	