

JUMO GmbH & Co. KG
 Delivery address: Mackenrodtstraße 14
 36039 Fulda, Germany
 Postal address: 36035 Fulda, Germany
 Phone: +49 661 6003-0
 Fax: +49 661 6003-607
 Email: mail@jumo.net
 Internet: www.jumo.net

JUMO Instrument Co. Ltd.
 JUMO House
 Temple Bank, Riverway
 Harlow, Essex, CM20 2DY, UK
 Phone: +44 1279 63 55 33
 Fax: +44 1279 62 50 29
 Email: sales@jumo.co.uk
 Internet: www.jumo.co.uk

JUMO Process Control, Inc.
 6733 Myers Road
 East Syracuse, NY 13057, USA
 Phone: +1 315 437 5866
 Fax: +1 315 437 5860
 Email: info.us@jumo.net
 Internet: www.jumousa.com



JUMO TYA 201 Single-Phase Thyristor Power Controller

For controlling resistive/inductive loads

The JUMO TYA 201 represents a consistent further development of the JUMO power controller technology. The micro-processor controlled power controller displays all parameters in a back-lighted LCD display and is operated using the 4 keys on the front.

Thyristor power controllers are employed where larger resistive and inductive loads have to be switched, e.g. in industrial kiln construction and in plastics processing. The Thyristor power controller comprises two Thyristors connected in anti-parallel, the insulated cooling body and the control electronics.

Thyristor power controllers up to a load current of 32 A can either be clipped onto a 35 mm mounting rail or fitted to the wall with a mounting plate.

Units with a load current greater than 32A have to be fitted to the wall.

Depending on their configuration via the setup program, the Thyristor power controllers operate with phase-angle control, in burst-firing mode or in half-wave operation.

In burst-firing mode, the phase angle can be cut back for the first half-cycle, for driving transformer loads.

Available subordinate controls are U, U², I, I² and P control.

Use of a subordinate control ensures that fluctuations in the supply voltage do not affect the control loop during the control process.

It is possible to preset a base load and a max. output level.

During a soft start, the default phase angle of the controller is reached slowly, starting at 180 degrees, in order to avoid high starting or inrush currents. The Thyristor power controllers comply with the operating conditions according to DIN EN 50178.

Grounding is required in conformity with the regulations of the responsible electrical utility company.



Type 709061/ ...

Block diagram

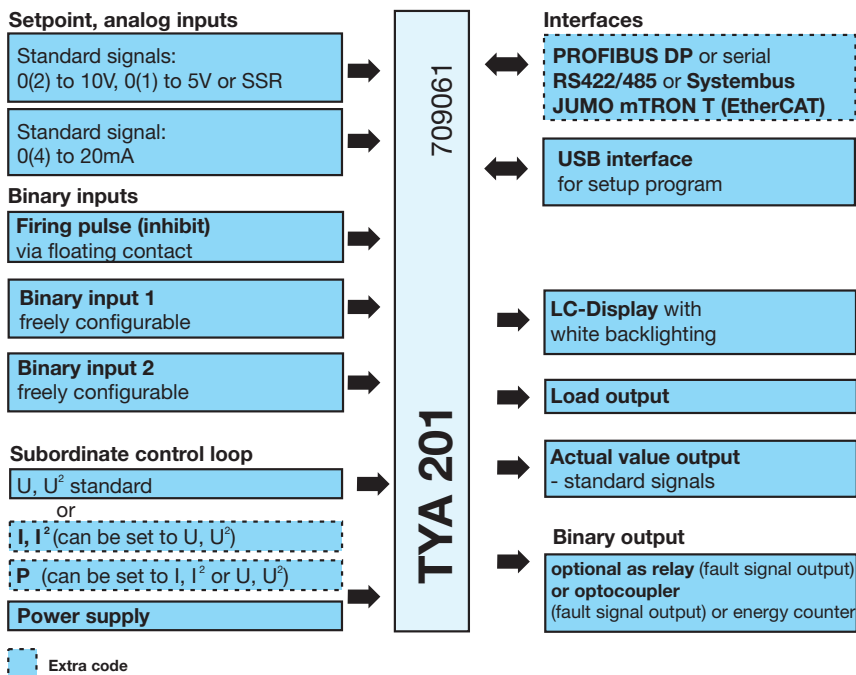

Special features

- Phase angle control and burst-firing mode
- Half-wave operation for vibrators
- LCD display with info line
- Simple configuration of the device via clear text display in the operator's language
- Setup program for configuration via USB interface
- Transmission of the setup data is also possible without voltage supply to the unit (supply via USB port)
- Close installation is possible
- Mains load optimization through dual energy management
- RS422/485 interface or
- PROFIBUS DP for connection to process control systems
- Systembus JUMO mTRON T or EtherCAT
- Current limiting function
- Soft start function
- Resistance monitoring and limitation for MoSi₂ heating elements
- All versions in protection rating IP20
- Load monitoring for the detection of partial load failure or load short circuit "teach-in"
- Integrated diagnosis systems
- Energy counter
- UL 508 Approval

Approvals/approval marks (see "Technical data")



JUMO GmbH & Co. KG
 Delivery address: Mackenrodtstraße 14
 36039 Fulda, Germany
 Postal address: 36035 Fulda, Germany
 Phone: +49 661 6003-0
 Fax: +49 661 6003-607
 Email: mail@jumo.net
 Internet: www.jumo.net

JUMO Instrument Co. Ltd.
 JUMO House
 Temple Bank, Riverway
 Harlow, Essex, CM20 2DY, UK
 Phone: +44 1279 63 55 33
 Fax: +44 1279 62 50 29
 Email: sales@jumo.co.uk
 Internet: www.jumo.co.uk

JUMO Process Control, Inc.
 6733 Myers Road
 East Syracuse, NY 13057, USA
 Phone: +1 315 437 5866
 Fax: +1 315 437 5860
 Email: info.us@jumo.net
 Internet: www.jumousa.com



Technical data

Voltage supply, fan voltage only with 250 A, load current

Code	Voltage supply for control electronics = mains voltage	Fan specifications Type 709061/X-0X-250...
024	AC 24V -20%...+15%, 48 ...63 Hz	AC 24V/30VA
042	AC 42V -20%...+15%, 48 ...63 Hz	AC 24V/30VA
115	AC 115V -20%...+15%, 48 ...63 Hz	AC 115V/30VA
230	AC 230V -20%...+15%, 48 ...63 Hz	AC 230V/30VA
265	AC 265V -20%...+15%, 48 ...63 Hz	AC 230V/30VA
400	AC 400V -20%...+15%, 48 ...63 Hz	AC 230V/30VA
460	AC 460V -20%...+15%, 48 ...63 Hz	AC 230V/30VA
500	AC 500V -20%...+15%, 48 ...63 Hz	AC 230V/30VA
Load current $I_{L\ rms}$	AC 20, 32, 50, 100, 150, 200, 250A	
Load type	Resistive and resistive/inductive loads	
Control section power consumption	max. 20 VA	

Analog inputs

Control signal	0(4) ... 20mA	$R_i = 50\ \Omega$
	0(2) ... 10V	$R_i = 25\ k\Omega$
	0(1) ... 5V	$R_i = 25\ k\Omega$
Default set point value	Via standard signals (current, voltage) or interface	
	Base load:	Output as minimum control value
	Maximum control value:	Output as maximum control value
Example P control:		

Binary inputs

Binary input 1, 2	For connection to potential-free contact or optocoupler, voltage proof up to DC 12V
-------------------	---

Binary outputs, actual value output

Relay (changeover contact) without contact suppression	30000 switching actions at a contact rating of 3A/230V 50Hz (resistive load) B300 (UL 508)
Optocoupler output	$I_{Cmax} = 2\ mA$, $U_{CE0max} = 32\ V$
Actual value output	Switched off as standard. For standard signal, voltage: 0 ... 10V, 2 ... 10V, 0 ... 5V to 1 ... 5V For standard signal, current: 0 ... 20mA to 4 ... 20mA (burden max. 500 Ω) Depending on the device type, the output of various internal measuring values such as load current, load voltage or power is possible.

Thyristor firing request:	setpoint specification Current input (current proof up to 25mA)	setpoint specification Voltage input (voltage proof up to DC 32V)	setpoint specification Binary input1, 2 (voltage proof up to DC 32V)	via Interface
continuous	The power controller provides the power for the load continuously depending on the default setpoint value.		-	possible
logic (Solid State Relais SSR)	The power controller acts like a switch and provides the power by either switching ON or OFF. The switching level is always in the middle of the selected input range. At 4 to 20mA it is 12mA, at 0 to 10V it is 5V.		ON logic level „1“ = DC +2 to 32V OFF logic level „0“ = DC 0 to +0,8V	possible

JUMO GmbH & Co. KG
 Delivery address: Mackenrodtstraße 14
 36039 Fulda, Germany
 Postal address: 36035 Fulda, Germany
 Phone: +49 661 6003-0
 Fax: +49 661 6003-607
 Email: mail@jumo.net
 Internet: www.jumo.net

JUMO Instrument Co. Ltd.
 JUMO House
 Temple Bank, Riverway
 Harlow, Essex, CM20 2DY, UK
 Phone: +44 1279 63 55 33
 Fax: +44 1279 62 50 29
 Email: sales@jumo.co.uk
 Internet: www.jumo.co.uk

JUMO Process Control, Inc.
 6733 Myers Road
 East Syracuse, NY 13057, USA
 Phone: +1 315 437 5866
 Fax: +1 315 437 5860
 Email: info.us@jumo.net
 Internet: www.jumousa.com



General characteristic data

Circuit options	<ul style="list-style-type: none"> - Single-phase operation - Star connection with accessible star point - Open delta connection (6-wire connection) - Free-running economy circuit (star or delta), only with cascade P control in burst-firing mode
Operating modes	<ul style="list-style-type: none"> - Phase-angle control for resistive and transformer loads with soft start - Burst-firing mode for resistive load or transformer load
Load types	All resistive loads through to inductive loads are permitted. For transformer loads the nominal induction of 1,2 Tesla must not be exceeded (for mains voltage peaks 1,45 T).
Special features	<ul style="list-style-type: none"> - Free-running economy circuit for resistive loads - Dual energy management - Half-wave control - Soft start with pulse groups - R-Control (only with integrated P-control)
Subordinate control loop	U ² control as standard Can be switched over to U, I, I ² , P control depending on device type
Electrical connection	For type 709061/X -0X-020... Control and load leads are connected via screw terminals. From type 709061/X -0X-032... Control leads are connected via screw terminals and load leads via cable lugs DIN 46235 and DIN46234 or tubular cable lugs.
Operating conditions	The controller is designed as a panel-mounting device according to: EN 50 178, pollution degree 2, overvoltage category Ü III
Electromagnetic compatibility	According to DIN 61326-1 Emitted interference: Class B Interference resistance: Industrial requirements
Protection rating	All device types IP20 according to EN 60 529
Protection rating	Protection rating I, with isolated control circuitry for connection to SELV circuits
Permissible ambient temperature range	0...40°C with forced air cooling (250A controller) 0 ... 45°C with natural air cooling (extended temperature range class 3K3 according to EN 60 721-3-3) At higher temperatures, operation with reduced type current is possible. (from 45°C with type current -2%/°C)
Permissible storage temperature range	-30 ... +70°C (1K5 according to EN 60 721-3-1)
Site altitude	≤ 2000m above sea level
Cooling	<ul style="list-style-type: none"> - Natural convection up to a load current of 200A - For a load current of 250A, forced convection with built-in ventilator - At site altitudes over 1000 m, the current carrying capacity of the power controller decreases
Environmental performance	Rel. humidity ≤ 85 % annual average, no condensation 3K3 according to EN 60 721
Installation position	Vertical
Test voltage	According to EN 50178
Creepage distances	8 mm between supply current circuit and SELV circuits for type 709061/X -0X-020... 12.7 mm between supply current circuit and SELV circuits from type 709061/X -0X-032... SELV = Separate Extra Low Voltage (safe low voltage)
Case	Plastic, flammability class UL94 V0, color: Cobalt blue RAL 5013
Power dissipation	The power dissipation can be calculated using the following empirical formula: $P_v = 20W + 1.3V \times I_{Load} A$
Maximum temperature of the cooling body	110°C
A/D converter resolution	12 Bit

Weight

Type (Load current)	20A	32A	50A	100A	150A	200A	250A
Weight	approx. 1.1 kg	approx. 2.1 kg	approx. 2.7 kg	approx. 3.8 kg	approx. 8.5 kg	approx. 9.5 kg	approx. 10.2 kg

JUMO GmbH & Co. KG
 Delivery address: Mackenrodtstraße 14
 36039 Fulda, Germany
 Postal address: 36035 Fulda, Germany
 Phone: +49 661 6003-0
 Fax: +49 661 6003-607
 Email: mail@jumo.net
 Internet: www.jumo.net

JUMO Instrument Co. Ltd.
 JUMO House
 Temple Bank, Riverway
 Harlow, Essex, CM20 2DY, UK
 Phone: +44 1279 63 55 33
 Fax: +44 1279 62 50 29
 Email: sales@jumo.co.uk
 Internet: www.jumo.co.uk

JUMO Process Control, Inc.
 6733 Myers Road
 East Syracuse, NY 13057, USA
 Phone: +1 315 437 5866
 Fax: +1 315 437 5860
 Email: info.us@jumo.net
 Internet: www.jumousa.com



Approvals/approval marks

Approval mark	Testing agency	Certificates / certification numbers	Inspection basis	Valid for
	Underwriters Laboratories	E223137	UL 508 (Category NRNT), pollution degree 2 C22.2 NO. 14-10 Industrial Control Equipment (Category NRNT7)	709061/X-XX-020-... Load current 20 A
			UL 508 (Category NRNT) C22.2 NO. 14-10 Industrial Control Equipment (Category NRNT7)	709061/X-XX-032... 709061/X-XX-050... 709061/X-XX-100... 709061/X-XX-150... 709061/X-XX-200... 709061/X-XX-250... Load current 32...250 A

Display and measuring accuracy

All specifications refer to the controller nominal data.

Supply voltage: ± 2,5% 	Load current: ± 1% 	Load voltage: ± 1% 	Power: ± 2% 	
Analog input Voltage/current: ± 1% 	Analog output Voltage/current: ± 1% 	Load resistance: ± 2% (for resistive load) 		

Permissible load current depending on the ambient temperature and site altitude

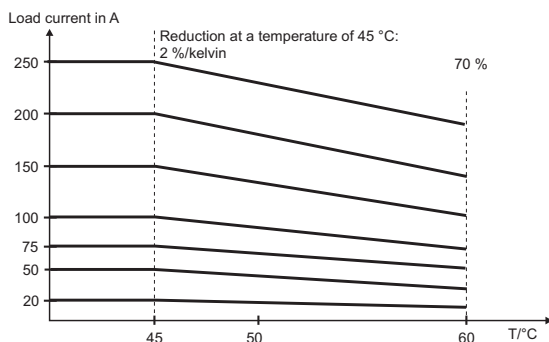

Note:

At a device temperature of 105°C, the load current is reduced for each degree of temperature increase. The power controller current is switched off completely at a device temperature of >115°C.

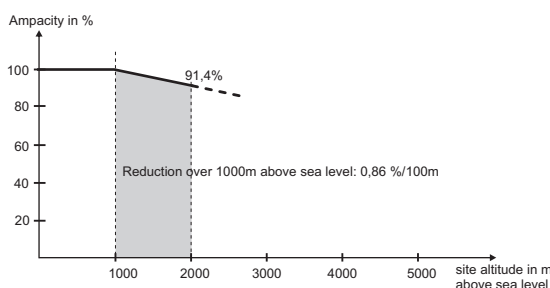

Note:

The altitude is ≤ 2000m above sea level. In the case of air cooling, it must be noted that the effectiveness of the cooling is reduced the higher up the device is installed. As a result, the current carrying capacity of the Thyristor power controller decreases with such a cooler as the site altitude increases as shown in the image.



Electrical isolation

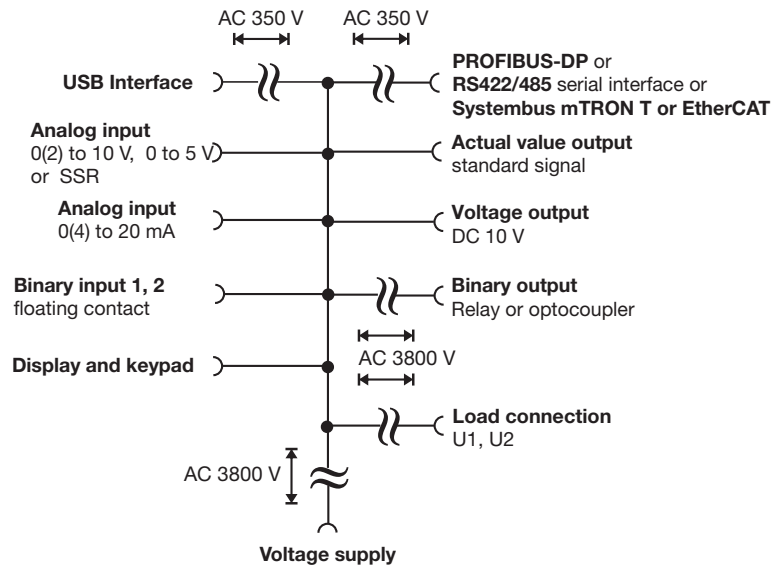

Display, operation and connection elements

Legend	Remark	Fig.
1	LED Power (green) is lit when the voltage supply is connected	
2	LCD display with white background lighting (96 x 64 pixels). The info line at the bottom of the display indicates current settings and error messages.	
3	The LED Fuse (red) is lit when the semi-conductor fuse is blown	
4	LED K1 (yellow) fault signal output	
5	Keys: Increase value / parameter up Decrease value / parameter down Abort / one level back Programming / one level lower	
6	USB setup interface	
7	Release clip for removing the plastic case (push to the right)	

JUMO GmbH & Co. KG
 Delivery address: Mackenrodtstraße 14
 36039 Fulda, Germany
 Postal address: 36035 Fulda, Germany
 Phone: +49 661 6003-0
 Fax: +49 661 6003-607
 Email: mail@jumo.net
 Internet: www.jumo.net

JUMO Instrument Co. Ltd.
 JUMO House
 Temple Bank, Riverway
 Harlow, Essex, CM20 2DY, UK
 Phone: +44 1279 63 55 33
 Fax: +44 1279 62 50 29
 Email: sales@jumo.co.uk
 Internet: www.jumo.co.uk

JUMO Process Control, Inc.
 6733 Myers Road
 East Syracuse, NY 13057, USA
 Phone: +1 315 437 5866
 Fax: +1 315 437 5860
 Email: info.us@jumo.net
 Internet: www.jumousa.com



Dimensions

Type 709061/X-0X-020-XXX-XXX-XX-25X

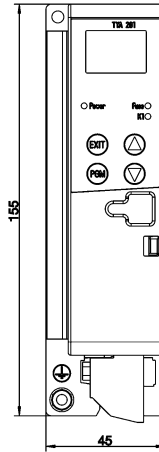
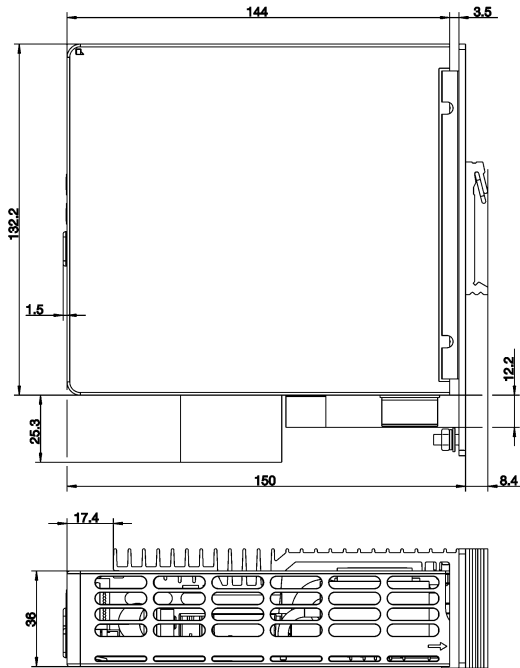

Type 709061/X-0X-032-XXX-XXX-XX-25X

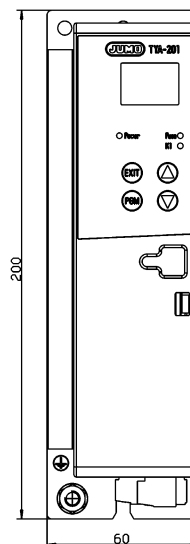
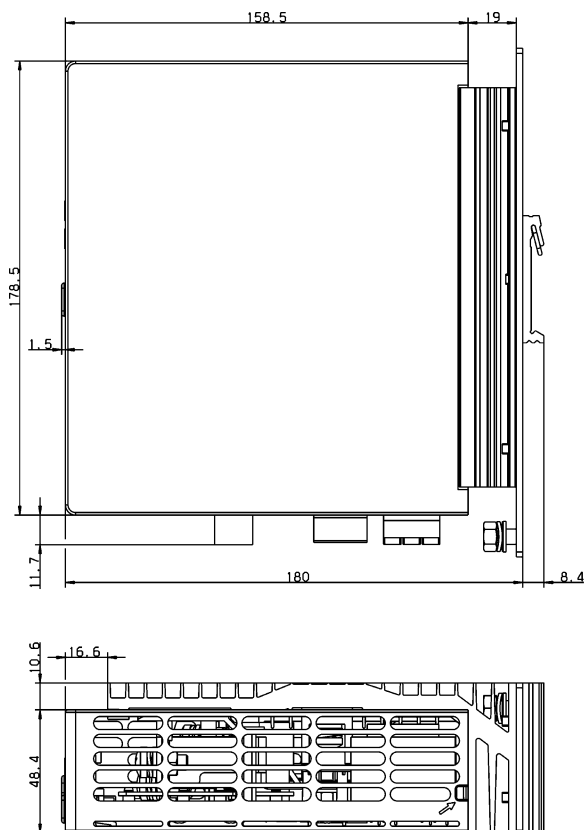

JUMO GmbH & Co. KG
 Delivery address: Mackenrodtstraße 14
 36039 Fulda, Germany
 Postal address: 36035 Fulda, Germany
 Phone: +49 661 6003-0
 Fax: +49 661 6003-607
 Email: mail@jumo.net
 Internet: www.jumo.net

JUMO Instrument Co. Ltd.
 JUMO House
 Temple Bank, Riverway
 Harlow, Essex, CM20 2DY, UK
 Phone: +44 1279 63 55 33
 Fax: +44 1279 62 50 29
 Email: sales@jumo.co.uk
 Internet: www.jumo.co.uk

JUMO Process Control, Inc.
 6733 Myers Road
 East Syracuse, NY 13057, USA
 Phone: +1 315 437 5866
 Fax: +1 315 437 5860
 Email: info.us@jumo.net
 Internet: www.jumousa.com



Type 709061/X-0X-050-XXX-XXX-XX-25X

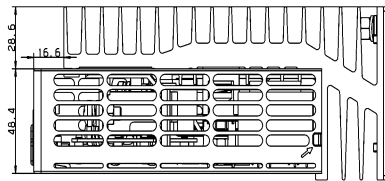
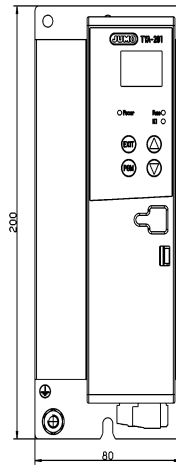
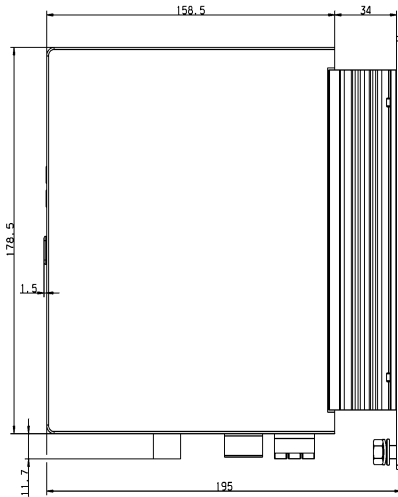

Type 709061/X-0X-100-XXX-XXX-XX-25X

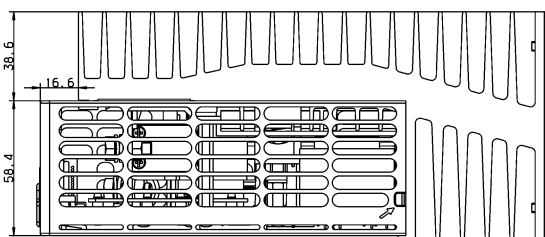
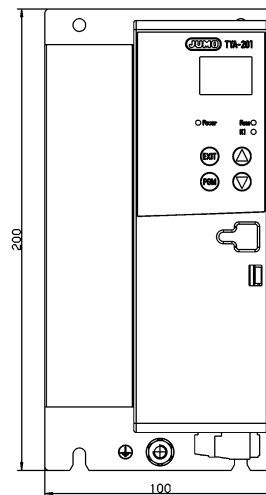
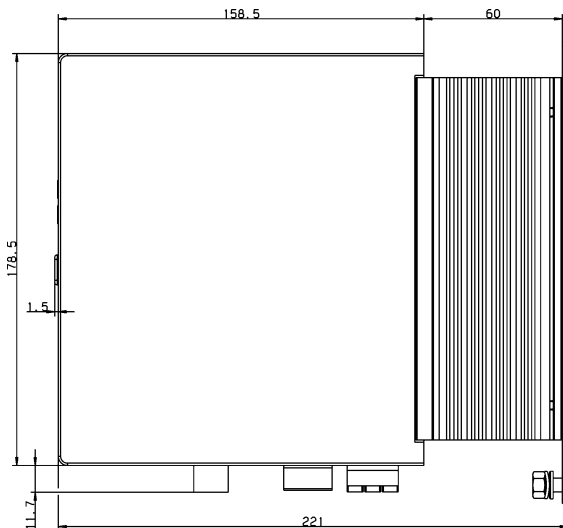

JUMO GmbH & Co. KG

Delivery address: Mackenrodtstraße 14
36039 Fulda, Germany
Postal address: 36035 Fulda, Germany
Phone: +49 661 6003-0
Fax: +49 661 6003-607
Email: mail@jumo.net
Internet: www.jumo.net

JUMO Instrument Co. Ltd.

JUMO House
Temple Bank, Riverway
Harlow, Essex, CM20 2DY, UK
Phone: +44 1279 63 55 33
Fax: +44 1279 62 50 29
Email: sales@jumo.co.uk
Internet: www.jumo.co.uk

JUMO Process Control, Inc.

6733 Myers Road
East Syracuse, NY 13057, USA
Phone: +1 315 437 5866
Fax: +1 315 437 5860
Email: info.us@jumo.net
Internet: www.jumousa.com



Type 709061/X-0X-150-XXX-XXX-XX-25X
Type 709061/X-0X-200-XXX-XXX-XX-25X,

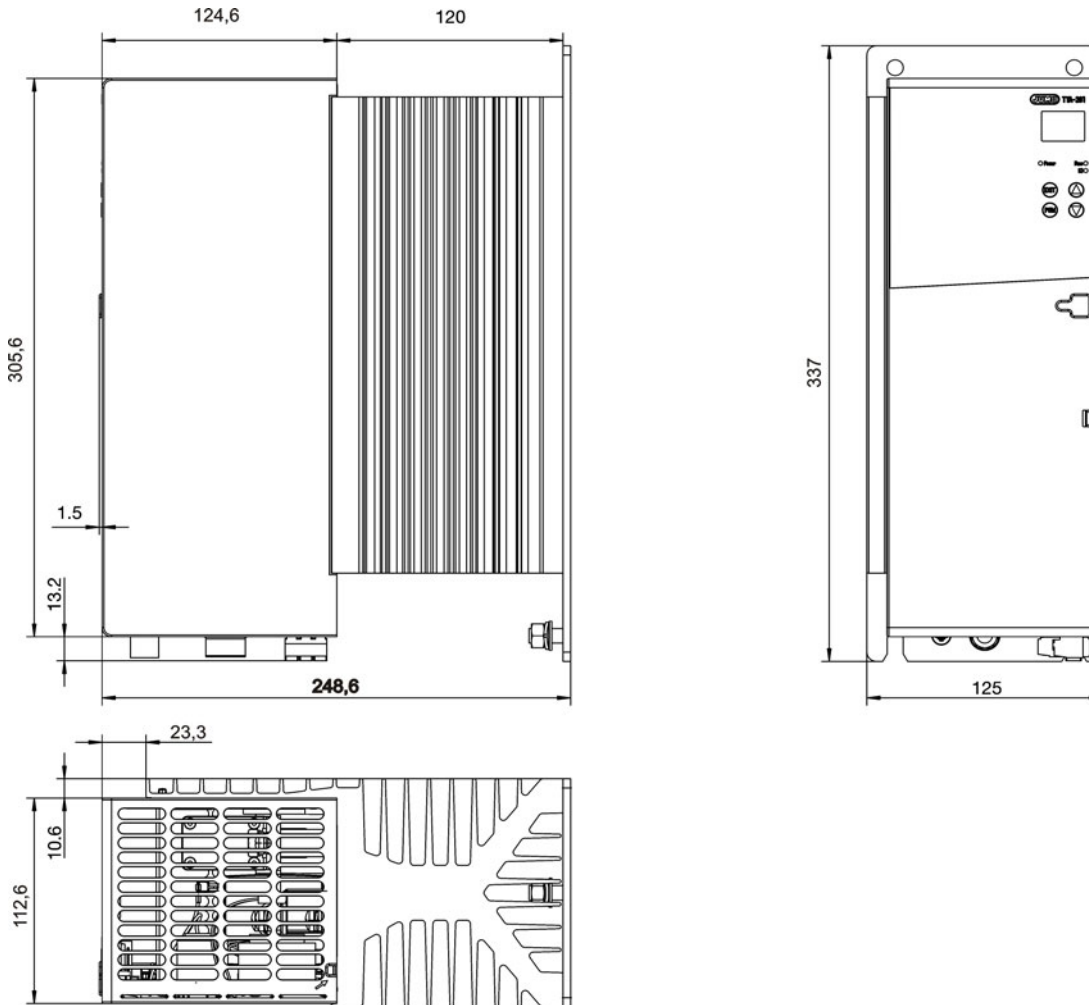

Clearances (all types)

- Allow a clearance of 10 cm from the floor.
- Allow a clearance of 15 cm from the ceiling.
- When fitted next to each other, no spacing between the devices is required.

JUMO GmbH & Co. KG
 Delivery address: Mackenrodtstraße 14
 36039 Fulda, Germany
 Postal address: 36035 Fulda, Germany
 Phone: +49 661 6003-0
 Fax: +49 661 6003-607
 Email: mail@jumo.net
 Internet: www.jumo.net

JUMO Instrument Co. Ltd.
 JUMO House
 Temple Bank, Riverway
 Harlow, Essex, CM20 2DY, UK
 Phone: +44 1279 63 55 33
 Fax: +44 1279 62 50 29
 Email: sales@jumo.co.uk
 Internet: www.jumo.co.uk

JUMO Process Control, Inc.
 6733 Myers Road
 East Syracuse, NY 13057, USA
 Phone: +1 315 437 5866
 Fax: +1 315 437 5860
 Email: info.us@jumo.net
 Internet: www.jumousa.com



Type 709061/X-0X-250-XXX-XXX-XX-25X

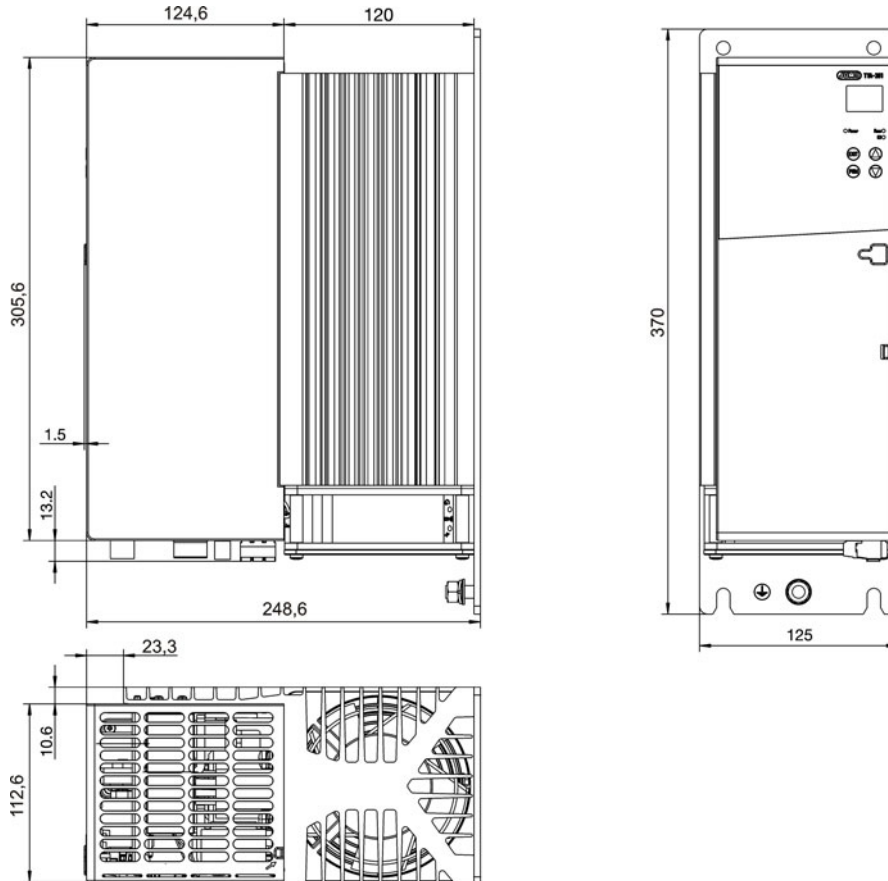

Maximum tightening torques for screw connections

Terminals	Version	Tightening torque
For all types X2_1 numbers 1...6, X2_2 numbers 7...12 and modbus RS422/485 (Terminals 16, 17, 18, 19)	Plug-in screw terminals (slotted screws)	0.25 Nm
X3 numbers 13, 14, 15	Plug-in screw terminals (slotted screws)	0.5 Nm
Type 709061/X-0X-020... Clamping block U1, U2, N/L2, V, L1 Ground terminal PE:	Plug-in screw terminals (recessed head screws) M4 headless setscrew with nut	0.6 Nm 3 Nm
Type 709061/X-0X-032 and type 709061/X-0X-050... U1, U2: Clamping block N/L2, V, L1 Ground terminal PE:	M6 recessed head screws Plug-in screw terminals (slotted screws) M6 headless setscrew with nut	5 Nm 0.5 Nm 5 Nm
Type 709061/X-0X-100... U1, U2: Clamping block N/L2, V, L1 Ground terminal PE:	M6 hexagon screw, width across flats 10 mm Plug-in screw terminals (slotted screws) M6 headless setscrew with nut	5 Nm 0.5 Nm 5 Nm
Type 709061/X-0X-150..., 709061/X-0X-200 and Type 709061/X-0X-250... U1, U2: Clamping block N/L2, V, L1 Ground terminal PE:	M8 hexagon screw, width across flats 13 mm Plug-in screw terminals (slotted screws) M8 headless setscrew with nut	12 Nm 0.5 Nm 12 Nm
Typ 709061/X-0X-250... X14 numbers 20, 21	Plug-in screw terminals (slotted screws)	0,5 Nm

JUMO GmbH & Co. KG
 Delivery address: Mackenrodtstraße 14
 36039 Fulda, Germany
 Postal address: 36035 Fulda, Germany
 Phone: +49 661 6003-0
 Fax: +49 661 6003-607
 Email: mail@jumo.net
 Internet: www.jumo.net

JUMO Instrument Co. Ltd.
 JUMO House
 Temple Bank, Riverway
 Harlow, Essex, CM20 2DY, UK
 Phone: +44 1279 63 55 33
 Fax: +44 1279 62 50 29
 Email: sales@jumo.co.uk
 Internet: www.jumo.co.uk

JUMO Process Control, Inc.
 6733 Myers Road
 East Syracuse, NY 13057, USA
 Phone: +1 315 437 5866
 Fax: +1 315 437 5860
 Email: info.us@jumo.net
 Internet: www.jumousa.com



Connection diagram

The connection diagram contained in the data sheet provides preliminary information about the connection possibilities. For electrical connection, only use the installation instructions or the operating instructions. The knowledge and correct technical execution of the safety instructions, and observance of the warnings contained in these documents are prerequisite for installation, electrical connection and commissioning/start-up as well as for safety during operation.

Type 709061/X-0X-20-XXX-XXX-XX-25X

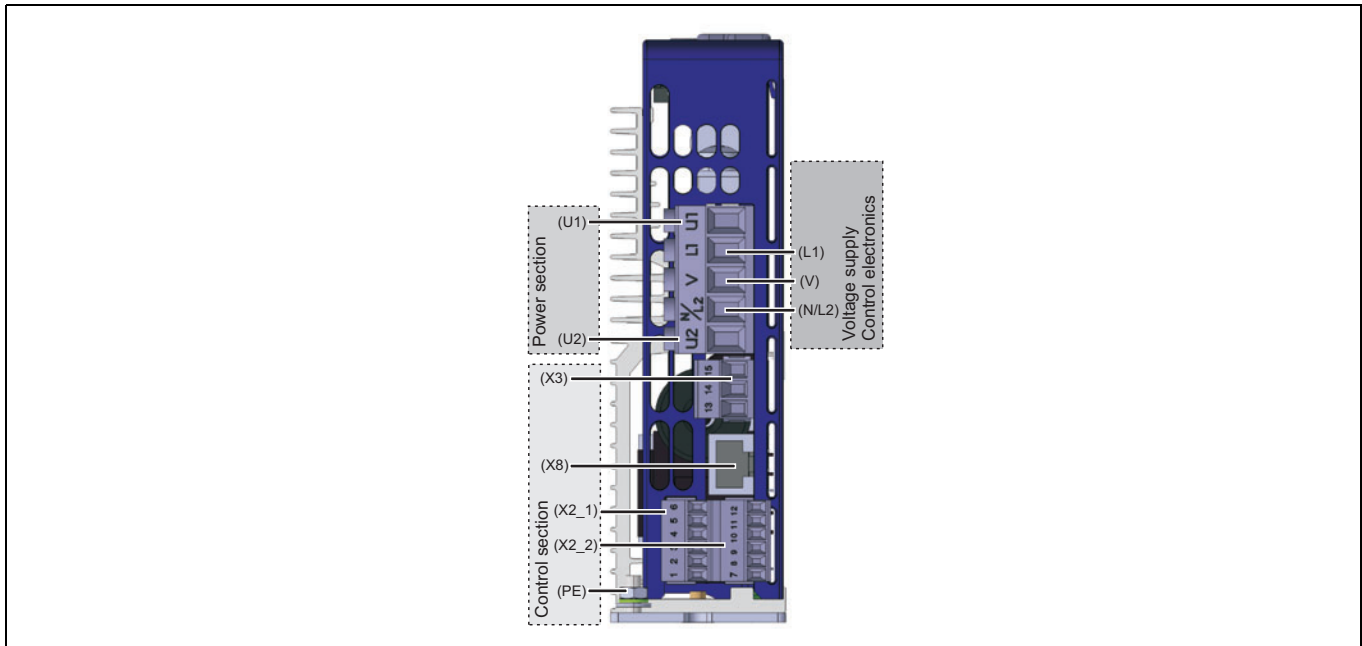

Power section		
Connection for	Screw terminals, control section/power section	Detail
Voltage supply for control electronics (corresponds to mains voltage of ordered device type)	L1 N/L2 V	
Load connection	U1 U2	
Protection conductor	PE	
Fan X14	20, 21 (only for load current of 250 A)	

Control section

Connection for	Screw terminal X2_1	Detail
Setpoint specification for current input	1 2	
Setpoint specification for voltage input (surge proof up to max. DC 32 V)	3 (GND) (for continuous control) 4	<p>external Setpoint specification with potentiometer</p>
Binary input SPS 0/24 V ON logical „1“ = DC +5...32 V OFF logical „0“ = DC 0...< 5 V	3 (GND) (for SPS-Logic signals) 4	
Output DC 10 V fixed voltage	5	
Ground potential	6 (GND)	

JUMO GmbH & Co. KG
 Delivery address: Mackenrodtstraße 14
 36039 Fulda, Germany
 Postal address: 36035 Fulda, Germany
 Phone: +49 661 6003-0
 Fax: +49 661 6003-607
 Email: mail@jumo.net
 Internet: www.jumo.net

JUMO Instrument Co. Ltd.
 JUMO House
 Temple Bank, Riverway
 Harlow, Essex, CM20 2DY, UK
 Phone: +44 1279 63 55 33
 Fax: +44 1279 62 50 29
 Email: sales@jumo.co.uk
 Internet: www.jumo.co.uk

JUMO Process Control, Inc.
 6733 Myers Road
 East Syracuse, NY 13057, USA
 Phone: +1 315 437 5866
 Fax: +1 315 437 5860
 Email: info.us@jumo.net
 Internet: www.jumousa.com



Connection for	Screw terminal X2_2	Detail
Firing pulse inhibit ON logical "1" = DC 2 to 32 V OFF logical "0" = DC 0 to 0.8 V	8 (not for SPS-Logic signals) 7 (GND)	
Digital input1 ON logical "1" = DC 2 to 32 V OFF logical "0" = DC 0 to 0.8 V	9 (not for SPS-Logic signals) 11 (GND)	
Digital input2 ON logical "1" = DC 2 to 32 V OFF logical "0" = DC 0 to 0.8 V	10 (not for SPS-Logic signals) 11 (GND)	
GND	7, 11	Ground potential
Analog output for various internal controller variables	12	

Fault signal output

Connection for	Screw terminal X3	Detail
Relay or optocoupler is on Slave2 at load current of 20 A and on Master at 32...250 A	13 N/O contact or collector 14 N/C contact 15 pole or emitter	

Interfaces (option)

Modbus connection	RS422	RS485	JUMO mTRON T system bus or EtherCAT conf. tested	Connection	PROFIBUS-DP
 Pluggable screw terminals on the underside of the housing	TxD (-) TxD (+) RxD (-) RxD (+)	RxD/TxD B(-) RxD/TxD A(+) - -	 1 TX+ Transmission data+ 2 TX- Transmission data - 3 RX+ Received data + 6 RX Received data -	SUB-D socket 9-pin (on the front)	3 A(+) 8 B(-) 6 VCC 5 GND Shielding
The shield of the Modbus cables must be routed on ground potential (PE)			2 RJ-45 sockets (on the front) 		

JUMO GmbH & Co. KG
 Delivery address: Mackenrodtstraße 14
 36039 Fulda, Germany
 Postal address: 36035 Fulda, Germany
 Phone: +49 661 6003-0
 Fax: +49 661 6003-607
 Email: mail@jumo.net
 Internet: www.jumo.net

JUMO Instrument Co. Ltd.
 JUMO House
 Temple Bank, Riverway
 Harlow, Essex, CM20 2DY, UK
 Phone: +44 1279 63 55 33
 Fax: +44 1279 62 50 29
 Email: sales@jumo.co.uk
 Internet: www.jumo.co.uk

JUMO Process Control, Inc.
 6733 Myers Road
 East Syracuse, NY 13057, USA
 Phone: +1 315 437 5866
 Fax: +1 315 437 5860
 Email: info.us@jumo.net
 Internet: www.jumousa.com



Type 709061/X-0X-032-XXX-XXX-XX-25X

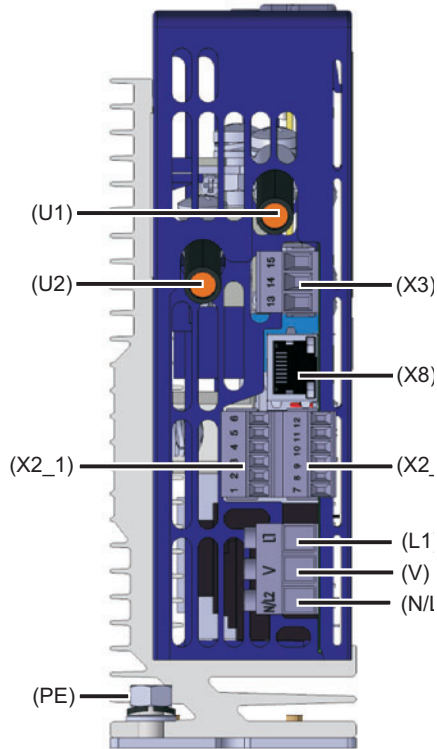

Type 709061/X-0X-050-XXX-XXX-XX-25X

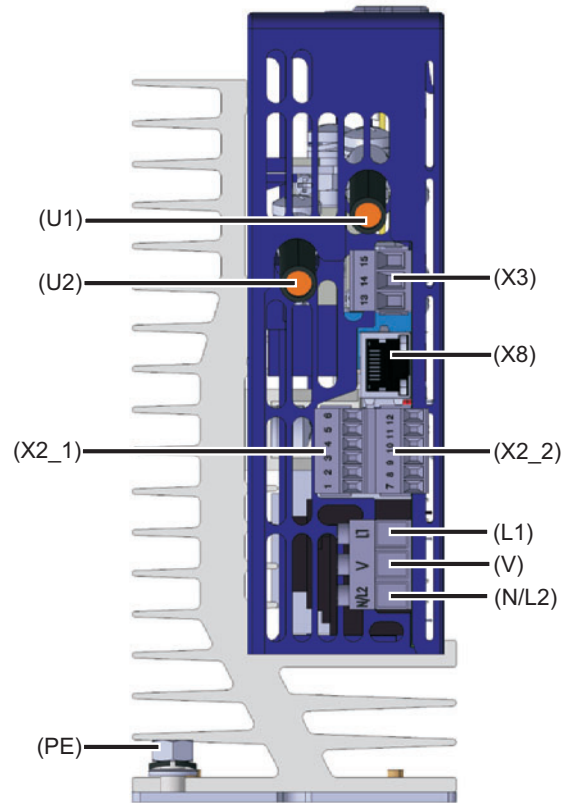

JUMO GmbH & Co. KG
 Delivery address: Mackenrodtstraße 14
 36039 Fulda, Germany
 Postal address: 36035 Fulda, Germany
 Phone: +49 661 6003-0
 Fax: +49 661 6003-607
 Email: mail@jumo.net
 Internet: www.jumo.net

JUMO Instrument Co. Ltd.
 JUMO House
 Temple Bank, Riverway
 Harlow, Essex, CM20 2DY, UK
 Phone: +44 1279 63 55 33
 Fax: +44 1279 62 50 29
 Email: sales@jumo.co.uk
 Internet: www.jumo.co.uk

JUMO Process Control, Inc.
 6733 Myers Road
 East Syracuse, NY 13057, USA
 Phone: +1 315 437 5866
 Fax: +1 315 437 5860
 Email: info.us@jumo.net
 Internet: www.jumousa.com



Type 709061/X-0X-100-XXX-XXX-XX-25X

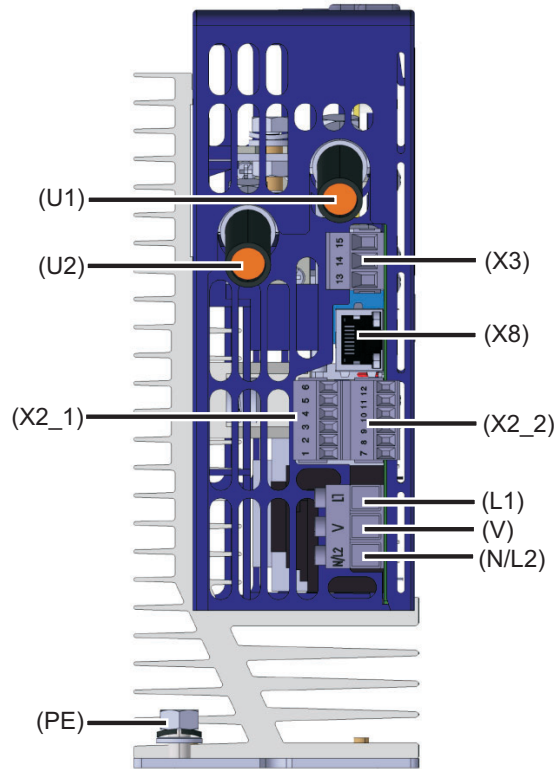

**Type 709061/X-0X-150-XXX-XXX-XX-25X,
 Type 709061/X-0X-200-XXX-XXX-XX-25X**

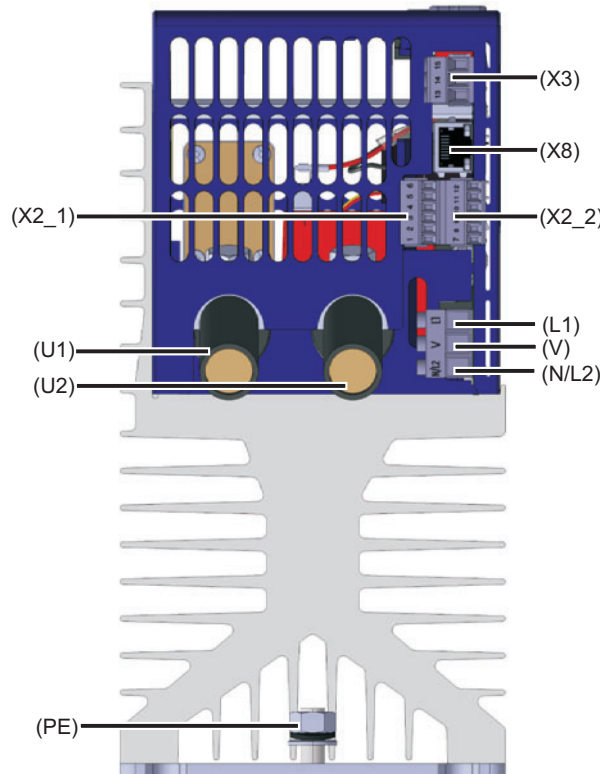

JUMO GmbH & Co. KG
 Delivery address: Mackenrodtstraße 14
 36039 Fulda, Germany
 Postal address: 36035 Fulda, Germany
 Phone: +49 661 6003-0
 Fax: +49 661 6003-607
 Email: mail@jumo.net
 Internet: www.jumo.net

JUMO Instrument Co. Ltd.
 JUMO House
 Temple Bank, Riverway
 Harlow, Essex, CM20 2DY, UK
 Phone: +44 1279 63 55 33
 Fax: +44 1279 62 50 29
 Email: sales@jumo.co.uk
 Internet: www.jumo.co.uk

JUMO Process Control, Inc.
 6733 Myers Road
 East Syracuse, NY 13057, USA
 Phone: +1 315 437 5866
 Fax: +1 315 437 5860
 Email: info.us@jumo.net
 Internet: www.jumousa.com



Type 709061/X-0X-250-XXX-XXX-XX-25X

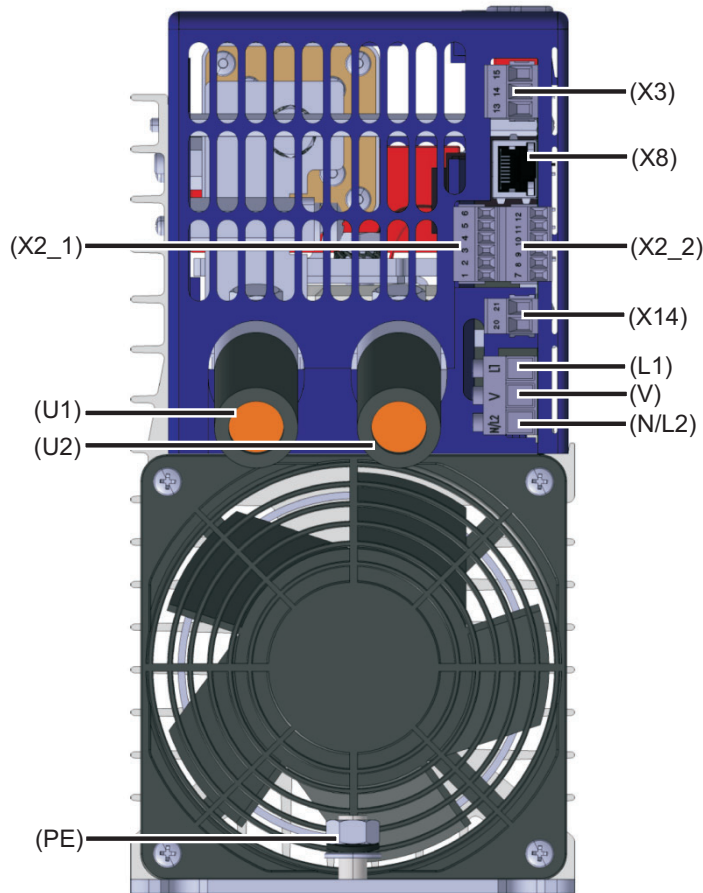

Example:

Voltage supply of the fan in case of type 709061/X-0X-250-XXX-400-XX-25X

Depending on the mains voltage, the fan terminal X14 must be supplied with the voltage specified below.

The lead protection must be between 2 A and a maximum of 5 A.

The fan is temperature-controlled, switches on automatically when the device temperature reaches 85 °C, and remains in operation until the device temperature falls below 70 °C.

Mains voltage on the power controller	Tolerances	Fan specifications
Mains voltage AC 24V	-20 to +15 %, 48 to 63 Hz	AC24V / 30VA
Mains voltage AC 42V		
Mains voltage AC115V	-15 to +10 %, 48 to 63 Hz	AC 115V / 30VA
Mains voltage AC230V		AC 230V / 30VA
Mains voltage AC265V		
Mains voltage AC400V		
Mains voltage AC460V		
Mains voltage AC500V		

Wiring

Single-phase operation: phase / N

This circuit example can only be applied in TN-Systems. In TT-Systems additionally the neutral conductor has to be switched with S1 and S2.

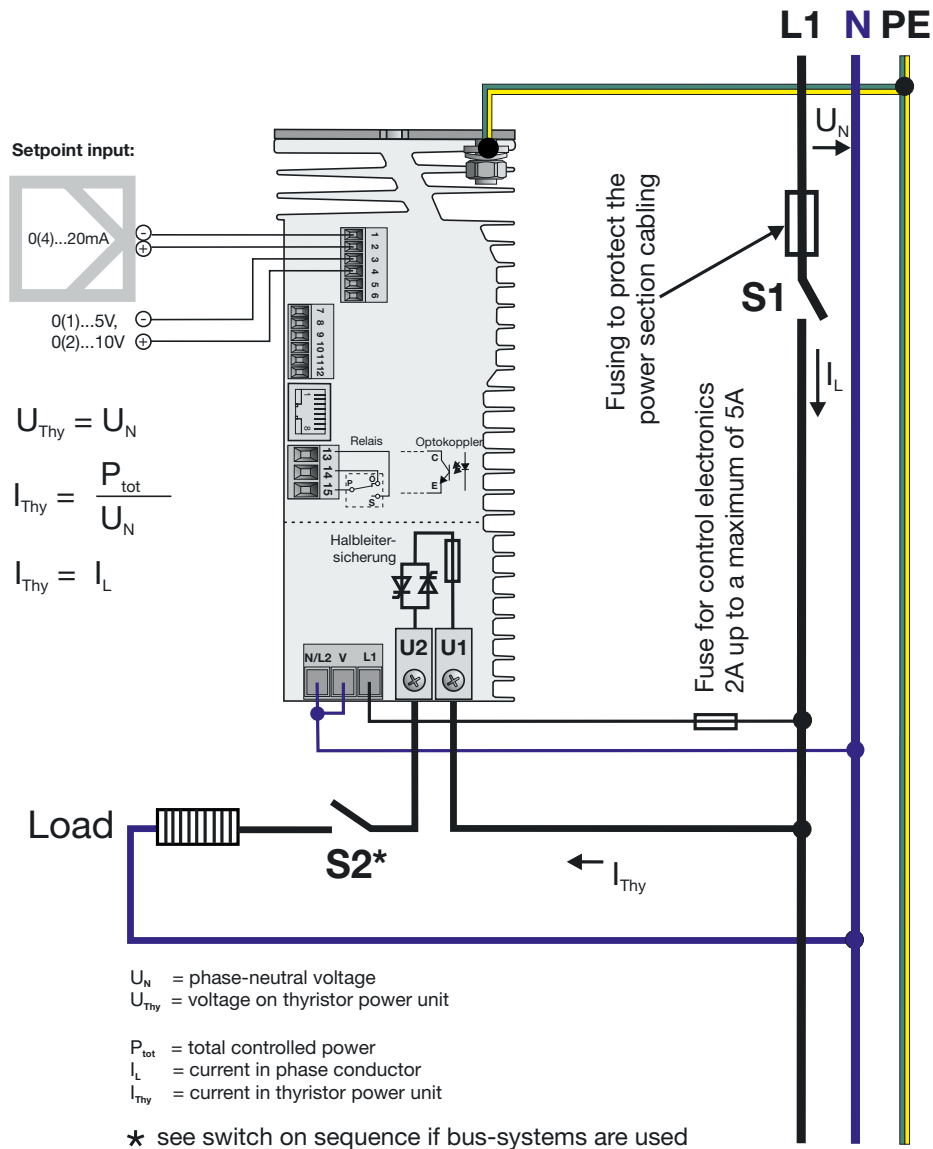

Note: In the case of power controllers with a load current of 250 A, the fan terminal X14 must also be supplied with the specified voltage!

⇒ Siehe "Example: Voltage supply of the fan in case of type 709061/X-0X-250-XXX-400-XX-25X" see page 14..

JUMO GmbH & Co. KG
 Delivery address: Mackenrodtstraße 14
 36039 Fulda, Germany
 Postal address: 36035 Fulda, Germany
 Phone: +49 661 6003-0
 Fax: +49 661 6003-607
 Email: mail@jumo.net
 Internet: www.jumo.net

JUMO Instrument Co. Ltd.
 JUMO House
 Temple Bank, Riverway
 Harlow, Essex, CM20 2DY, UK
 Phone: +44 1279 63 55 33
 Fax: +44 1279 62 50 29
 Email: sales@jumo.co.uk
 Internet: www.jumo.co.uk

JUMO Process Control, Inc.
 6733 Myers Road
 East Syracuse, NY 13057, USA
 Phone: +1 315 437 5866
 Fax: +1 315 437 5860
 Email: info.us@jumo.net
 Internet: www.jumousa.com



Single-phase operation: phase / phase

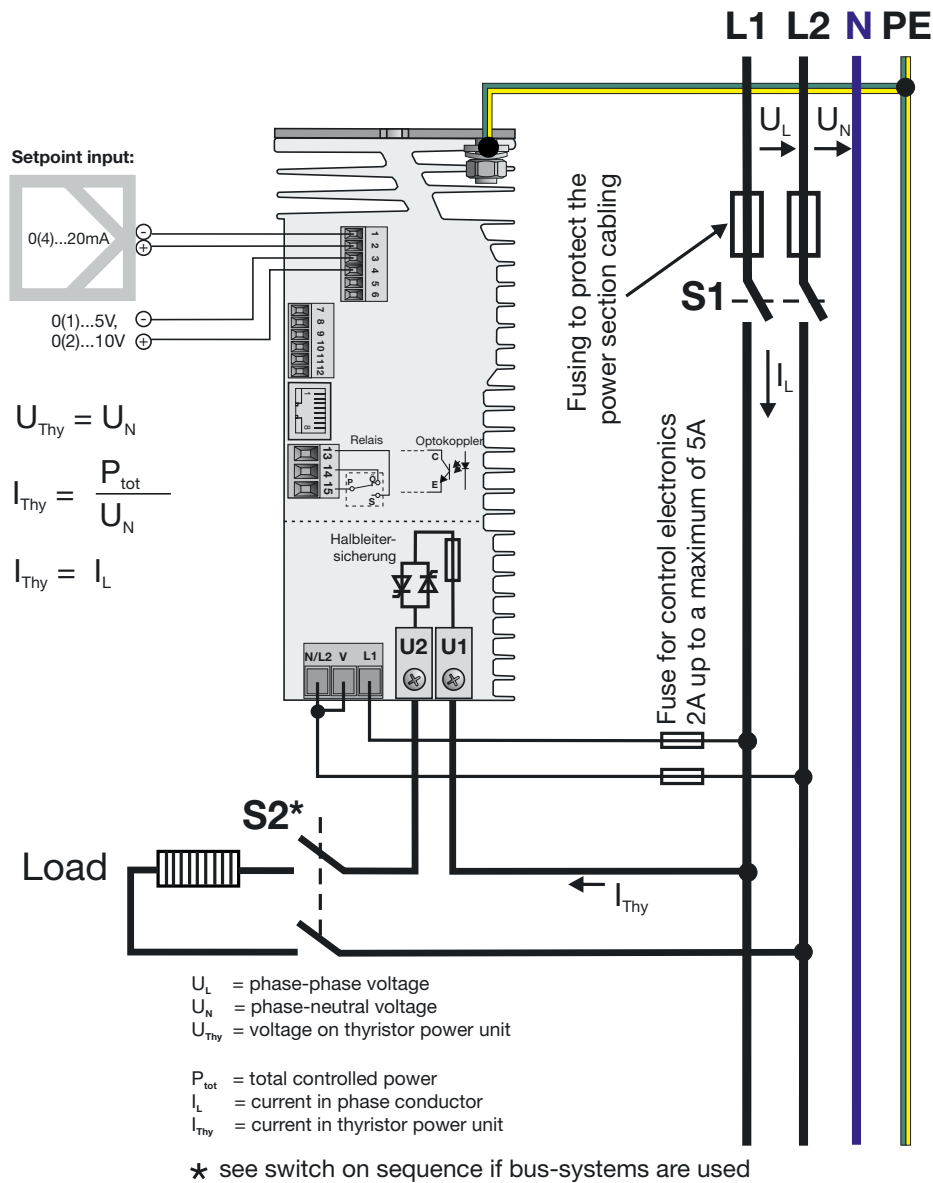

Note: In the case of power controllers with a load current of 250 A, the fan terminal X14 must also be supplied with the specified voltage!

⇒ Siehe "Example: Voltage supply of the fan in case of type 709061/X-0X-250-XXX-400-XX-25X" see page 14..

Star connection with accessible star point (N)

This circuit example can only be applied in TN-Systems. In TT-Systems additionally the neural conductor has to be switched with S1 and S2.

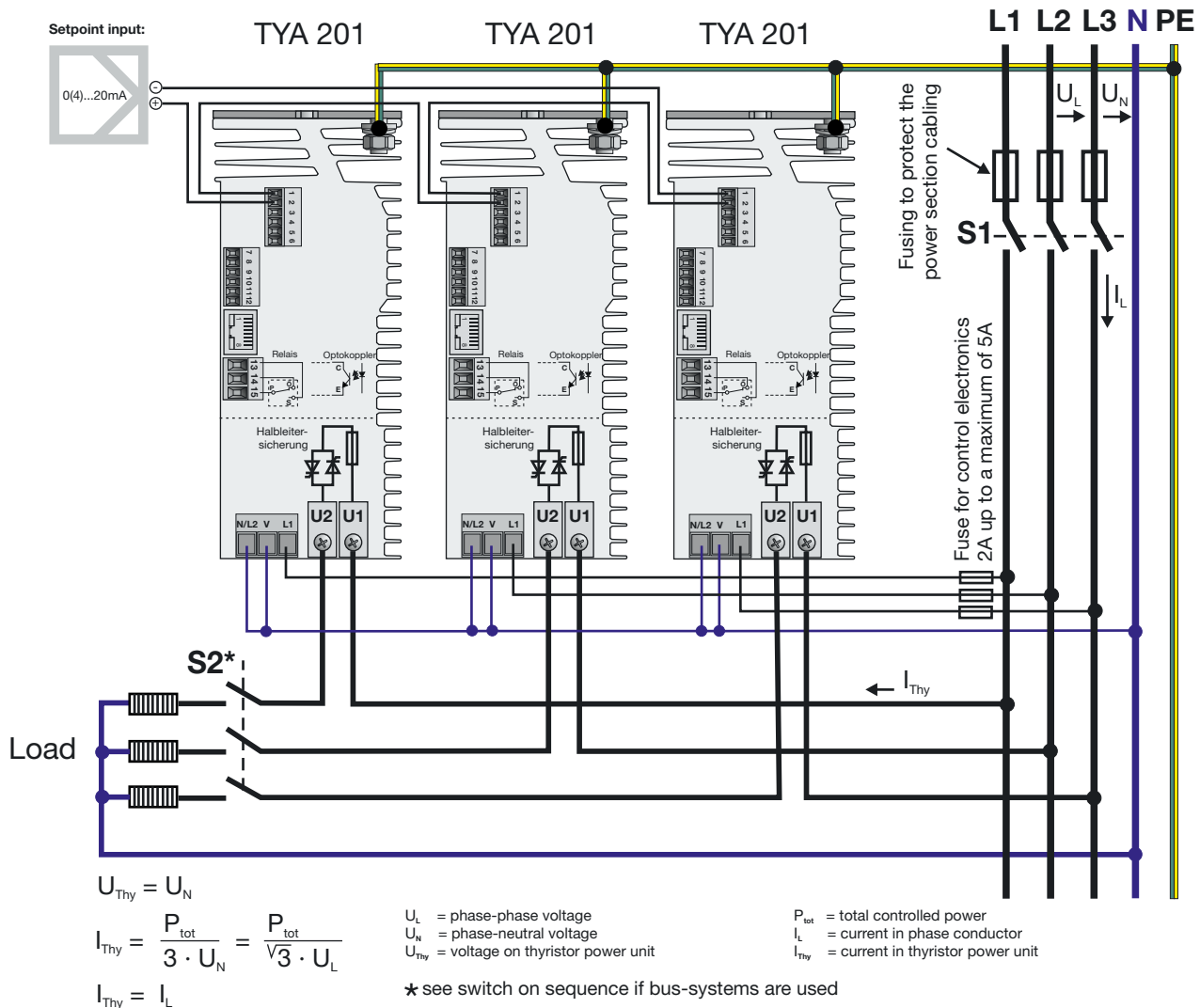

Note: In the case of power controllers with a load current of 250 A, the fan terminal X14 must also be supplied with the specified voltage!

⇒ Siehe "Example: Voltage supply of the fan in case of type 709061/X-0X-250-XXX-400-XX-25X" see page 14..

Open delta connection (six wire connection)

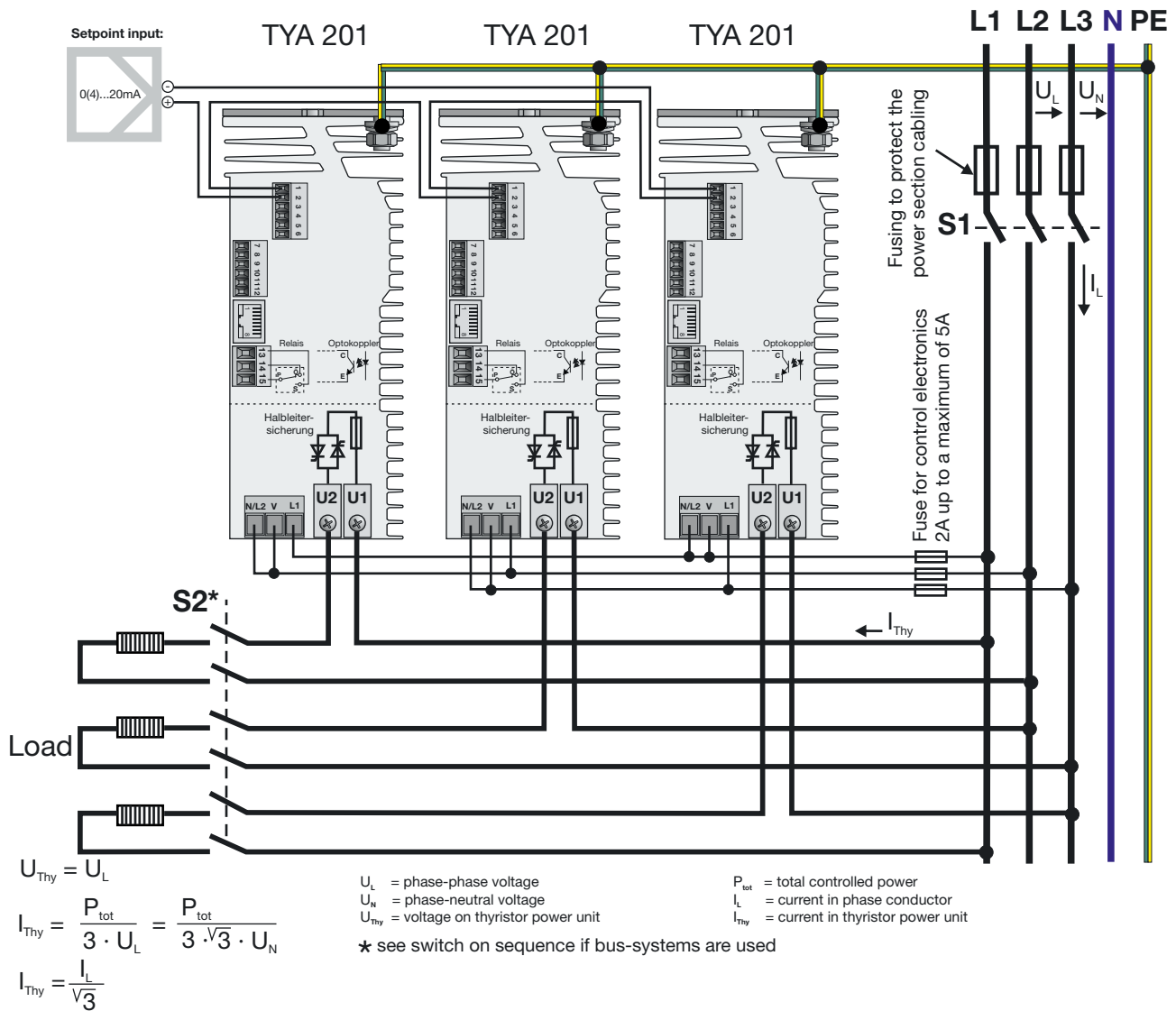

Note: In the case of power controllers with a load current of 250 A, the fan terminal X14 must also be supplied with the specified voltage!

⇒ Siehe "Example: Voltage supply of the fan in case of type 709061/X-0X-250-XXX-400-XX-25X" see page 14..

Free-running economy circuit with purely resistive loads

Attention:

- make sure that the rotating electrical field is right-handed!
- only possible in burst firing mode and subordinate control loop P

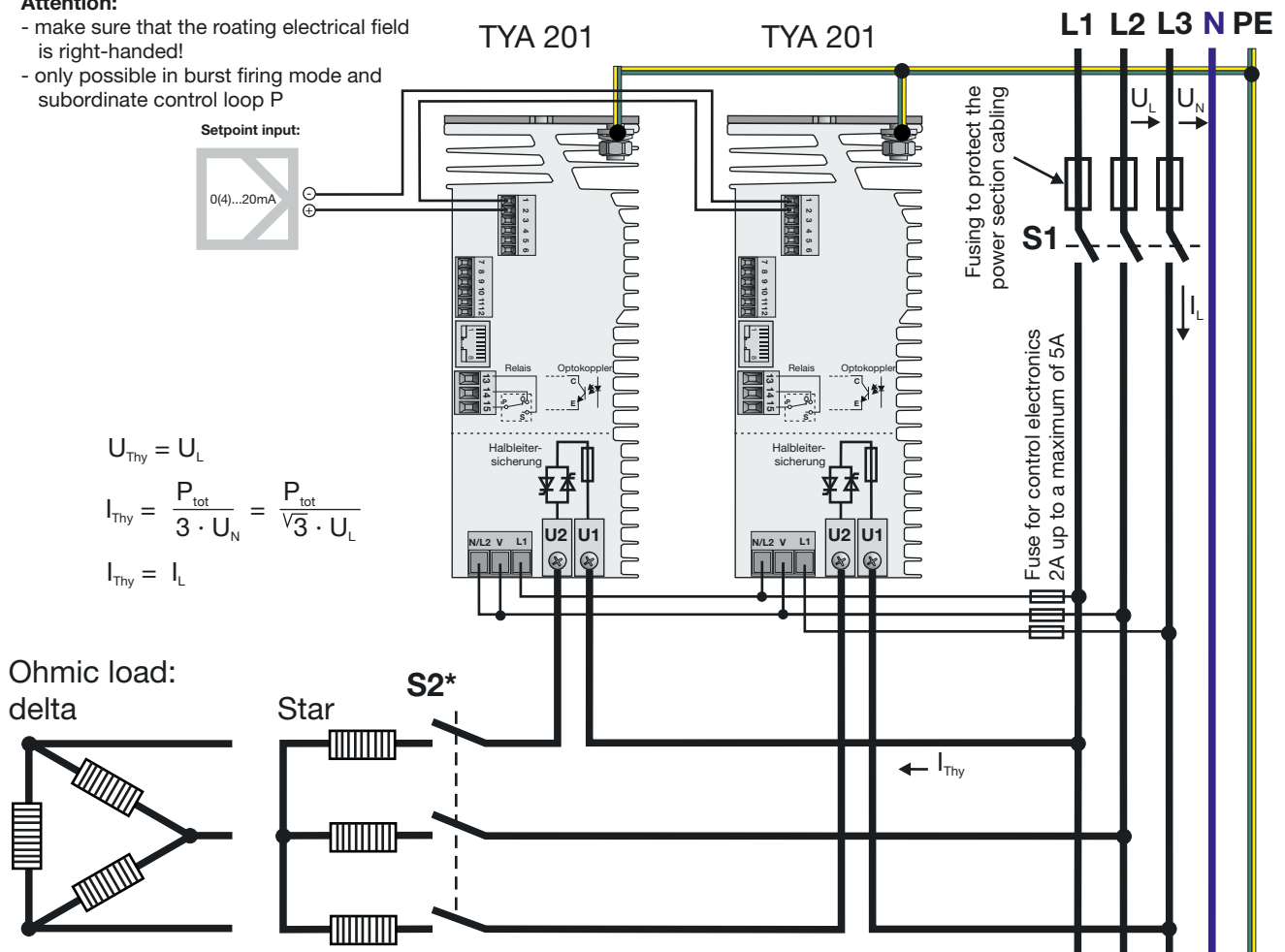

$$U_{Thy} = U_L$$

$$I_{Thy} = \frac{P_{tot}}{3 \cdot U_N} = \frac{P_{tot}}{\sqrt{3} \cdot U_L}$$

$$I_{Thy} = I_L$$

Ohmic load:
delta

Star

U_L = phase-phase voltage
 U_N = phase-neutral voltage
 U_{Thy} = voltage on thyristor power unit

P_{tot} = total controlled power
 I_L = current in phase conductor
 I_{Thy} = current in thyristor power unit

★ see switch on sequence if bus-systems are used

Observe the general switch-on sequence

The **S2** switch is not required if no bus system is used. The control section and power section are switched on simultaneously via switch **S1**. This is particularly important for the operation of transformer loads and resistance loads with a high temperature coefficient ($TC \gg 1$). This makes sure the necessary load start functions (soft start, current limiting, etc.) are activated accordingly.

Switch-on sequence when using bus systems

When using a bus system, the control section and power section are switched on via **S1** and **S2**. **The TYA's control section must remain connected to the mains voltage (S1 permanently closed)** to maintain the field bus communication. **S2** is used to activate the load. In the event of transformer loads or loads with a large temperature coefficient ($TC \gg 1$), the controller output must be blocked using the inhibit function prior to opening **S2**. After closing **S2**, the controller output must be reactivated via the inhibit function.

Note:

In the case of power controllers with a load current of 250 A, the fan terminal X14 must also be supplied with the specified voltage! Siehe "Example: Voltage supply of the fan in case of type 709061/X-0X-250-XXX-400-XX-25X" see page 14.

JUMO GmbH & Co. KG
 Delivery address: Mackenrodtstraße 14
 36039 Fulda, Germany
 Postal address: 36035 Fulda, Germany
 Phone: +49 661 6003-0
 Fax: +49 661 6003-607
 Email: mail@jumo.net
 Internet: www.jumo.net

JUMO Instrument Co. Ltd.
 JUMO House
 Temple Bank, Riverway
 Harlow, Essex, CM20 2DY, UK
 Phone: +44 1279 63 55 33
 Fax: +44 1279 62 50 29
 Email: sales@jumo.co.uk
 Internet: www.jumo.co.uk

JUMO Process Control, Inc.
 6733 Myers Road
 East Syracuse, NY 13057, USA
 Phone: +1 315 437 5866
 Fax: +1 315 437 5860
 Email: info.us@jumo.net
 Internet: www.jumousa.com



Order details

(1) Basic type

709061	TYA 201 single-phase thyristor power controller
--------	---

(2) Version

8	Standard with factory settings
9	Customer-specific programming according to specifications

(3) National language of display texts

01	German (set at factory)
02	English
03	French

(4) Load current

020	AC 20 A
032	AC 32 A
050	AC 50 A
100	AC 100 A
150	AC 150 A
200	AC 200 A
250	AC 250 A

(5) Subordinate control loop

100	U, U²
010	I, I² (can be set to U, U ²)
001	P (can be set to I, I ² or U, U ²)

(6) Mains voltage ^a

024	AC 24 V	-20 to +15 %, 48 to 63 Hz
042	AC 42 V	-20 to +15 %, 48 to 63 Hz
115	AC 115 V	-20 to +15 %, 48 to 63 Hz
230	AC 230 V	-20 to +15 %, 48 to 63 Hz
265	AC 265 V	-20 to +15 %, 48 to 63 Hz
400	AC 400 V	-20 to +15 %, 48 to 63 Hz
460	AC 460 V	-20 to +15 %, 48 to 63 Hz
500	AC 500 V	-20 to +15 %, 48 to 63 Hz

(7) Interface

00	None
54	RS485/422
64	PROFIBUS-DP
84	EtherCAT/JUMO mTRON T system interface

(8) Extra codes

252	Relay (changeover contact) 3 A
257	Optocoupler ^b

(1) / (2) - (3) - (4) - (5) - (6) - (7) / (8) Order code
 709061 / 8 - 01 - 100 - 100 - 400 - 00 / 252 Order example

^a Mains Voltage = voltage supply for control electronics

^b Enables energy counter

Important **Subordinate control loop U, U²** code 100: voltage control

information: **Subordinate control loop I²**, code 010: enables voltage control, current control, partial load failure detection, dual energy management, current limiting and energy counter

Subordinate control loop P, code 001: enables voltage control, current control, power control, partial load failure detection, dual energy management, current limiting, r-control and and energy counter

Note fan voltage at 250 A load current!

JUMO GmbH & Co. KG

Delivery address: Mackenrodtstraße 14
36039 Fulda, Germany
Postal address: 36035 Fulda, Germany
Phone: +49 661 6003-0
Fax: +49 661 6003-607
Email: mail@jumo.net
Internet: www.jumo.net

JUMO Instrument Co. Ltd.

JUMO House
Temple Bank, Riverway
Harlow, Essex, CM20 2DY, UK
Phone: +44 1279 63 55 33
Fax: +44 1279 62 50 29
Email: sales@jumo.co.uk
Internet: www.jumo.co.uk

JUMO Process Control, Inc.

6733 Myers Road
East Syracuse, NY 13057, USA
Phone: +1 315 437 5866
Fax: +1 315 437 5860
Email: info.us@jumo.net
Internet: www.jumousa.com



Scope of delivery

1 Operating manual
1 Thyristor power controller in the version ordered

Accessories

Part	Part no.
Setup program 709061 (TYA 201), 709062 (TYA 202), and 709063 (TYA 203)	00544869
USB cable A-plug B-plug 3m	00506252
Mounting kit for DIN rail installation:	
Installation kit for mounting rail 20A TYA 201	00555169
Installation kit for mounting rail 32A TYA 201	00555526
Installation kit for mounting rail 50A TYA 201	00600095

General accessories

Item	Load current $I_{Rated} = I_N$	Part no.
709710/02 semiconductor fuse 40 A / AC 690 V	$I_N = 20 \text{ A}$	00513108
709710/02 semiconductor fuse 80 A / AC 690 V	$I_N = 32 \text{ A}$	00068011
709710/02 semiconductor fuse 80 A / AC 690 V	$I_N = 50 \text{ A}$	00068011
709710/02 semiconductor fuse 160 A / AC 690 V	$I_N = 100 \text{ A}$	00081801
709710/02 semiconductor fuse 350 A / AC 690 V	$I_N = 150 \text{ A}$	00083318
709710/02 semiconductor fuse 550 A / AC 690 V	$I_N = 200 \text{ A}$	00371964
709710/02 semiconductor fuse 550 A / AC 690 V	$I_N = 250 \text{ A}$	00371964