



ELECTRONICS, INC.
 44 FARRAND STREET
 BLOOMFIELD, NJ 07003
 (973) 748-5089
<http://www.nteinc.com>

NTE7451 Integrated Circuit TTL – Dual AND/OR Invert Gate

Description:

The NTE7451 is a dual AND/OR invert gate in a 14-Lead plastic DIP type package that contains two independent 2-wide 2-input AND/OR Invert gates that perform the Boolean function $1Y = \overline{AB + CD}$.

Absolute Maximum Ratings: (Note 1)

Supply Voltage, V_{CC} 7V
 Input Voltage 5.5V
 Operating Temperature Range, T_A 0°C to +70°C
 Storage Temperature Range, T_{stg} -65°C to +150°C

Note 1. Voltage values are with respect to network ground terminal..

Recommended Operating Conditions:

Parameter	Symbol	Min	Typ	Max	Unit
Supply Voltage	V_{CC}	4.75	5.0	5.25	V
High-Level Input Voltage	V_{IH}	2	-	-	V
Low-Level Input Voltage	V_{IL}	-	-	0.8	V
High-Level Output Current	I_{OH}	-	-	-0.4	mA
Low-Level Output Current	I_{OL}	-	-	16	mA
Operating Temperature Range	T_A	0	-	+70	°C

Electrical Characteristics: (Note 2, Note 3)

Parameter	Symbol	Test Conditions	Min	Typ	Max	Unit
Input Clamp Voltage	V_{IK}	$V_{CC} = \text{MIN}, I_I = -12\text{mA}$	-	-	-1.5	V
High Level Output Voltage	V_{OH}	$V_{CC} = \text{MIN}, V_{IL} = 0.8\text{V}, I_{OH} = -0.4\text{mA}$	2.4	3.4	-	V
Low Level Output Voltage	V_{OL}	$V_{CC} = \text{MIN}, V_{IH} = 2\text{V}, I_{OL} = 16\text{mA}$	-	0.2	0.4	V
Input Current	I_I	$V_{CC} = \text{MAX}, V_I = 5.5\text{V}$	-	-	1	mA

Note 2. For conditions shown as MIN or MAX, use the appropriate value specified under “Recommended Operation Conditions”.

Note 3. All typical values are at $V_{CC} = 5\text{V}, T_A = +25^\circ\text{C}$.

Electrical Characteristics (Cont'd): (Note 2, Note 3)

Parameter	Symbol	Test Conditions	Min	Typ	Max	Unit
High Level Input Current	I_{IH}	$V_{CC} = \text{MAX}, V_I = 2.4V$	-	-	40	μA
Low Level Input Current	I_{IL}	$V_{CC} = \text{MAX}, V_I = 0.4V$	-	-	-1.6	mA
Short-Circuit Output Current	I_{OL}	$V_{CC} = \text{MAX}, \text{Note 4}$	-18	-	-55	mA
Supply Current	I_{CCH}	$V_{CC} = \text{MAX}, V_I = 0V$	-	4	8	mA
	I_{CCL}	$V_{CC} = \text{MAX}, \text{Note 5}$	-	7.4	14	mA

Note 2. For conditions shown as MIN or MAX, use the appropriate value specified under "Recommended Operation Conditions".

Note 3. All typical values are at $V_{CC} = 5V, T_A = +25^\circ C$.

Note 4. Not more than one output should be shorted at a time.

Note 5. All inputs of one AND gate at 4.5V, all others at GND

Switching Characteristics: ($V_{CC} = 5V, T_A = +25^\circ C$ unless otherwise specified)

Parameter	Symbol	Test Conditions	Min	Typ	Max	Unit
Propagation Delay Time (From Any Input to Y Output)	t_{PLH}	$R_L = 400\Omega, C_L = 15pF$	-	13	22	ns
	t_{PHL}		-	8	15	ns

Logic Diagram

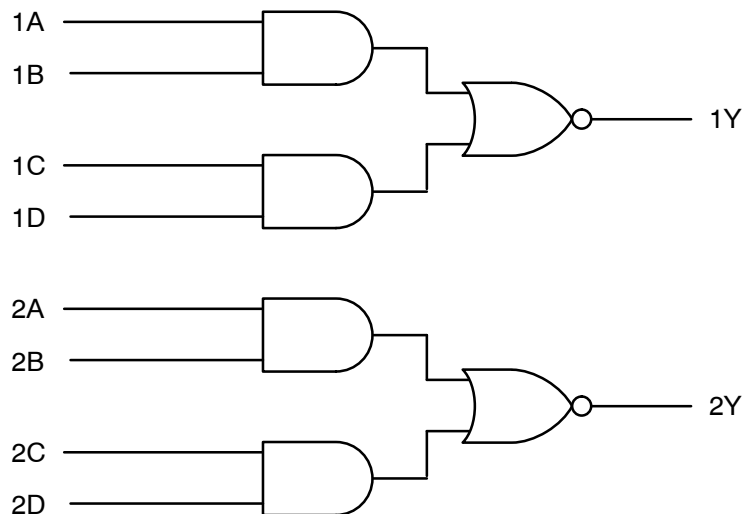

Pin Connection Diagram

