

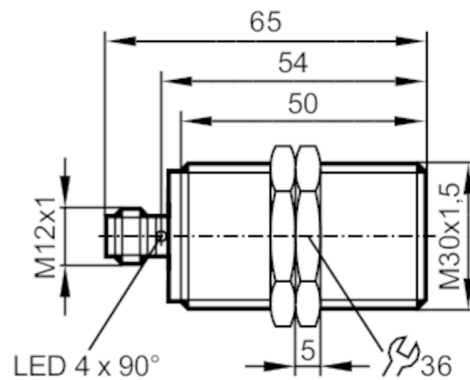

## Inductive sensor

IIK3015BBPKG/US-104



### Product characteristics

Electrical design	PNP
Output function	normally open
Sensing range [mm]	15
Housing	threaded type
Dimensions [mm]	M30 x 1.5 / L = 65

### Application

Special feature	Gold-plated contacts; Increased sensing range
Application	Industrial applications / factory automation

### Electrical data

Operating voltage [V]	10...30 DC
Current consumption [mA]	< 10
Protection class	III
Reverse polarity protection	yes

### Outputs

Electrical design	PNP
Output function	normally open
Max. voltage drop switching output DC [V]	2.5
Permanent current rating of switching output DC [mA]	200
Switching frequency DC [Hz]	100
Short-circuit protection	yes
Overload protection	yes

### Detection zone

Sensing range [mm]	15
Real sensing range Sr [mm]	15 ± 10 %
Operating distance [mm]	0...12.15
Increased sensing range	yes

# IIS218



## Inductive sensor

IIK3015BBPKG/US-104

Accuracy / deviations		
Correction factor	steel: 1 / stainless steel: 0.7 / brass: 0.5 / aluminium: 0.4 / copper: 0.3	
Hysteresis [% of Sr]	3...15	
Switch point drift [% of Sr]	-10...10	
Operating conditions		
Ambient temperature [°C]	-40...85	
Protection	IP 65; IP 66; IP 67; IP 68; IP 69K	
Tests / approvals		
EMC	EN 61000-4-2 ESD	4 kV CD / 8 kV AD
	EN 61000-4-3 HF radiated	10 V/m
	EN 61000-4-4 Burst	2 kV
	EN 61000-4-5 Surge	0,5 kV line to line, Ri: 2 Ohm
	EN 61000-4-6 HF conducted	10 V
	EN 55011 emission	class B
	signal-to-noise ratio walkie-talkie	150 MHz (5 W): 0 cm / 450 MHz (5 W): 0 cm / 900 MHz (2 W): 7,5 cm
Vibration resistance	EN 60068-2-6 Fc	20 g (10...3000 Hz) / 50 sweep cycles per frequency; 1 octave per minute in 3 axes
Shock resistance	EN 60068-2-27 Ea	100 g 11 ms half-sine; 3 shocks each in every direction of the 3 coordinate axes
Continuous shock resistance	EN 60068-2-27	40 g 6 ms; 4000 shocks each in every direction of the 3 coordinate axes
Fast temperature change	EN 60068-2-14 Na	TA = -40 °C; TB = 85 °C; t1 = 30 min; t2 = < 10 s; 50 cycles
Salt spray test	EN 60068-2-52 Kb	severity level 5 (4 test cycles)
MTTF [years]	1528	
Mechanical data		
Weight [g]	120.8	
Housing	threaded type	
Mounting	flush mountable	
Dimensions [mm]	M30 x 1.5 / L = 65	
Thread designation	M30 x 1.5	
Materials	brass white bronze coated; sensing face: PBT orange; LED window: PEI; lock nuts: brass white bronze coated	
Displays / operating elements		
Display	switching status	4 x LED, yellow
Accessories		
Accessories (supplied)	lock nuts: 2	
Remarks		
Pack quantity	1 pcs.	
Electrical connection - plug		
Connector: 1 x M12; Contacts: gold-plated		

# IIS218

## Inductive sensor

IHK3015BBPKG/US-104



### Connection

