

Shrink Disks ST

Material: High-quality steel.

- For very high torques.
- No axial shaft-hub movement.
- Quick mounting.
- Quick demounting.
- Not self-centering.
- Concentricity 0.02-0.04 mm.

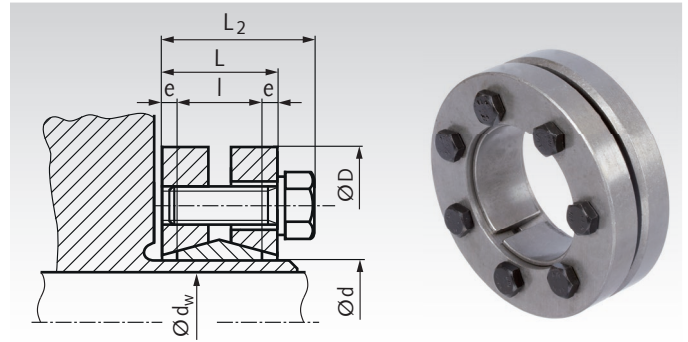

Ordering Details: e.g.: Product No. 61581400, Shrink Disk Inner-Ø 14 mm

Product No.	Inner-Ø d mm	Shaft-Ø ¹⁾ d _w mm	Torque ²⁾ T Nm	D mm	L mm	L ₂ mm	l mm	e mm	Fit tol. max. mm	Screws ISO 4017 No. x Size	Fastening Torque T _A Nm	Contact- pressure P _w N/mm ²	Weight kg
615 814 00	14	10	40	38	15	18,5	10	2,5	0,014	4 x M5 x 12	3	154	0,10
		11	50									191	
		12	65									243	
615 816 00	16	12	65	41	17	20,5	12	2,5	0,014	5 x M5 x 16	3	108	0,14
		13	80									151	
		14	95									190	
615 818 00	18	14	85	44	17	20,5	12	2,5	0,014	4 x M5 x 16	4	172	0,15
		15	100									205	
		16	130									233	
615 820 00	20	15	110	46	17	20,5	12	2,5	0,017	5 x M5 x 16	4	205	0,17
		16	130									232	
		17	150									258	
615 821 00	21	16	180	50	20	23,5	14	3	0,017	6 x M5 x 18	5	220	0,23
		17	220									245	
		18	270									275	
615 824 00	24	19	220	50	20	23,5	14	3	0,017	6 x M5 x 18	5	189	0,22
		20	280									209	
		21	330									228	
615 830 00	30	24	350	60	22	25,5	16	3	0,017	7 x M5 x 18	5	159	0,33
		25	400									172	
		26	470									184	
615 836 00	36	28	730	72	23,5	27,5	18	2,75	0,032	5 x M6 x 20	12	232	0,52
		30	860									240	
		31	880									250	
615 838 00	38	29	710	72	23,5	27,5	18	2,75	0,032	6 x M6 x 20	12	198	0,50
		30	735									205	
		31	760									211	
615 840 00	40	30	770	72	23,5	27,5	18	2,75	0,032	6 x M6 x 20	12	216	0,50
		31	800									223	
		32	825									230	
615 844 00	44	32	1200	80	25,5	29,5	20	2,75	0,032	7 x M6 x 20	12	225	0,64
		35	1400									235	
		36	1500									244	
615 850 00	50	38	1500	90	27,5	31,5	22	2,75	0,032	8 x M6 x 25	12	204	0,87
		40	1800									219	
		42	2100									232	
615 855 00	55	42	1700	100	30,5	34,5	23	3,75	0,032	8 x M6 x 25	12	176	1,18
		45	2100									193	
		48	2600									210	
615 862 00	62	48	2700	110	30,5	34,5	23	3,75	0,048	10 x M6 x 25	12	213	1,41
		50	3000									218	
		52	3200									222	
615 868 00	68	50	2500	115	30,5	34,5	23	3,75	0,048	10 x M6 x 25	12	184	1,46
		55	3100									188	
		60	4100									212	
615 875 00	75	55	3500	138	32,5	37,8	25	3,75	0,048	7 x M8 x 30	30	199	2,45
		60	4700									221	
		65	6000									241	

¹⁾ Shaft-Ø of the customer's machine (for example). ²⁾ Transmittable values with shaft-Ø d_w of the customer's machine, if the fit tolerance is complied.

More sizes up to inner-Ø d=280mm, for shaft diameter 230mm and 327,000Nm are available on request.

Surface Roughness, Tolerances and Mounting

Roughness: max, R_Z=16 µm. Outer-Ø tolerance of hub = h9.
Recommended tolerances for hub bore / shaft diameter:
from d_w Ø 30 = H6/j6; Ø 31-50 = H6/h6; Ø 51-65 = H6/g6.

It is essential to degrease the contact surfaces of shaft and hub bore. Lubricate only the shrink disk and the screws with MoS₂ and place it on the hub. Turn in the screws evenly by hand.

Fasten the tensioning screws evenly, in sequence (not crossing over) until the fastening torque T_A of the table is reached. To reach the value of T_A, several fastening steps are required. The figures for T stated in the table were calculated for a lubricated shrink disk.