

MATERIAL

Transparent polyamide based (PA-T) technopolymer. Highly resistant to shocks, solvents, oils with additives, aliphatic and aromatic hydrocarbons, petrol, naphtha, phosphoric esters. Avoid contact with alcohol or detergents containing alcohol.

SCREW, NUTS AND WASHERS

Zinc-plated steel.

PACKING RINGS

NBR synthetic rubber O-Ring. Suggested roughness of the packing ring application surface Ra = 3 µm.

FLOAT

Polyamide based (PA) expanded technopolymer, black colour, with a built-in magnetic element to activate the electric contact when the oil level drops to a minimum; alarm threshold located at about 50 mm from the centre of the lower nut (in presence of mineral oil type CB68, according to ISO 3498, at 23°C). Floating is ensured by fluids with densities higher than 800 kg/m³.

SENSOR BRACKET

Watertight in polypropylene based (PP) technopolymer, black colour, with a built-in relay (reed) with two conductors wired to the two-pin connector. For a correct assembly see Warnings (on page 1613).

TEMPERATURE ELECTRICAL PROBE

Zinc-plated steel screw with built-in probe. The probe is made out of a platinum resistor whose ohmic resistance changes according to the temperature.

SWIVELLING TWO-PIN CONNECTORS

With built-in cable glands and contact holders. Front or side output (right or left) including protection against water sprays (protection class IP 65 according to EN 60529 on page A-18) that can be increased during installation with the necessary adjustments. Flat NBR synthetic rubber packing rings.

CONTRAST SCREEN

White lacquered aluminium. The housing, in the appropriate external rear slot, guarantees the best protection from direct contact with fluid. It can be taken out from the inclined side, before assembly to allow the insertion of level lines or words.

STANDARD EXECUTIONS

- **HGX-E-STL-NO**: with electrical contact normally open.
- **HGX-E-STL-NC**: with electrical contact normally closed.

MOUNTING

When fitting is not possible from the inside of the reservoir and the walls are not thick enough, the screws can be used together with Fast Mounting Kit (see page 1597).

MAXIMUM CONTINUOUS WORKING TEMPERATURE

90°C (with oil).

FEATURES AND PERFORMANCES

This column level indicator generates an electric signal when the oil goes down to the minimum level allowed and an analogic electric signal of the oil temperature.

TECHNICAL DATA

In laboratory tests carried out with mineral oil type CB68 (according to ISO 3498) at 23°C for a limited period of time, the weld stood up to 13 bar.

For use with other fluids and under different pressure and temperature conditions, please contact ELESA Technical Department.

In any case we suggest to verify the suitability of the product under the actual working conditions.

SPECIAL EXECUTION ON REQUEST

UV resistant transparent technopolymer indicators.



ELESA Original design

FUNCTIONING OF THE MIN LEVEL ELECTRICAL SENSOR

- **HGX-E-STL-NO**: the electrical circuit is closed when the minimum level is reached.
- **HGX-E-STL-NC**: the electrical circuit is open when the minimum level is reached.

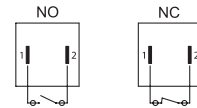

Electrical features	MIN level sensor
Power supply	AC/DC
Electric contacts	NO normally open NC normally closed
Maximum applicable voltage	NO: 150 Vac, 100 Vdc NC: 150 Vac, 150 Vdc
Maximum switching current	1 A
Maximum current	NO: 1A NC: 2A
Maximum commutable power	NO: 10 Va NC: 20 Va
Cable gland	Pg 7 (for cables in sheath with Ø 6 or 7 mm)
Conductors cross-section	Max. 1.5 mm ²
Do not mount this indicator in proximity to magnetic fields.	



Electrical features	Temperature probe
Power supply	DC
Maximum current	2 mA
Cable gland	Pg 7 (for cables in sheath with Ø 6 or 7 mm)
Conductors cross-section	Max. 1.5 mm ²

FUNCTIONING OF THE TEMPERATURE ELECTRICAL PROBE

The working principle of the temperature probe is to measure the variation of resistance of a platinum element: 100 ohm = 0°C, 138.4 ohm = 100°C. The function between temperature (T) and resistance (R) is approximately linear over a small temperature range: for example, if you assume that it is linear over the 0° to 100°C range, the error at 50°C is 0.4°C.

For precision measurement, it is necessary to linearise the resistance to give an accurate temperature. The most recent definition of the function between resistance and temperature is International Temperature Standard 90 (ITS-90). The function between resistance and temperature, obtained in laboratory tests, measuring directly the resistance value on the contacts is shown in the graph. We suggest, anyway, to set the system in order to compensate both heat dissipation and cable resistance.

A 1°C temperature change will cause a 0.384 ohm change in resistance, so even a small error in measurement of the resistance (for example, the resistance of the wires leading to the sensor) can cause a large error in the measurement of the temperature.

Because of the low signal levels, it is important to keep any cables away from electric cables, motors, switchgear and other devices that may emit magnetic or electrical noise. Using screened cable, with the screen grounded at one end, may help to reduce interference.

When using long cables, it is necessary to check that the measuring equipment is able to handle the cable resistance.

TWO-PIN CONNECTORS ASSEMBLY INSTRUCTIONS

1. Remove the connector from the indicator by unscrewing the set screw placed in the bottom, take the contact holder out and loosen the cable gland.
2. Slip on the two-pole cable into the connector (standard connector) and connect the wires to the terminals nr. 1 and nr. 2 of the relative contact holders.
3. Assembly by pressing the contact holders into the relative connectors in the required position.
4. Screw the connectors to the indicator and then tighten the cable glands.

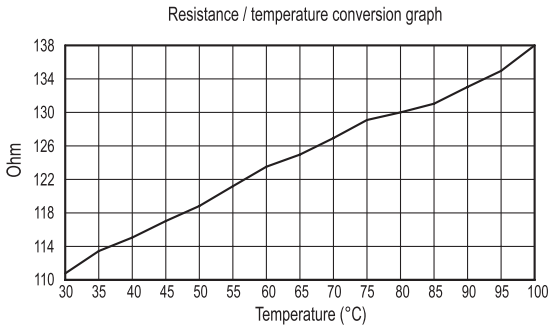
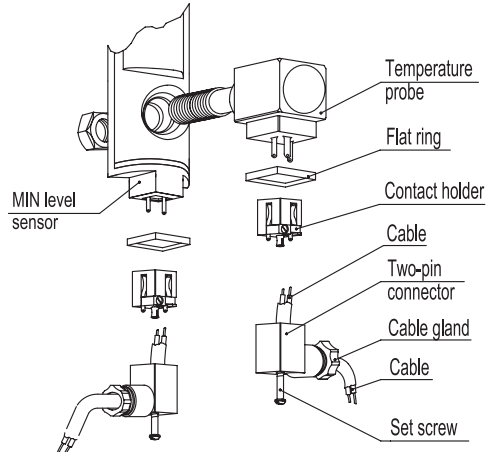

Drilling template
Holes without burrs and chamfer

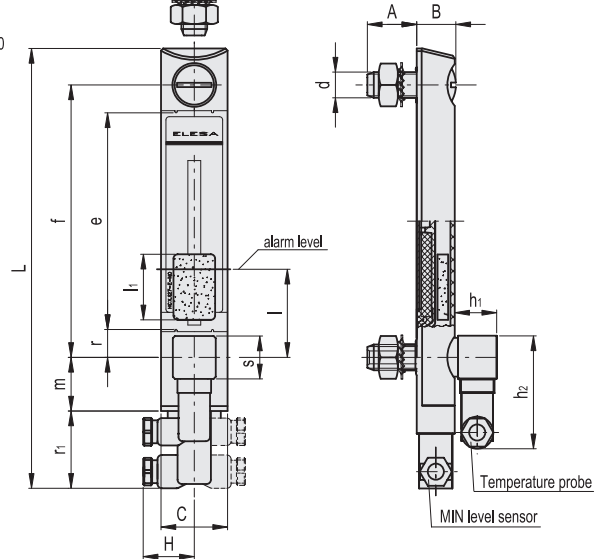
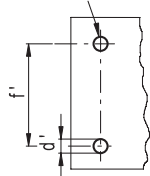

Code	Description	f	d	A	B	C	H	L	e	h1	h2	l	l1	m	r	r1	s	d'-0.2	f±0.2	C#	Δ
11156	HCX.127-E-STL-NO-M12	127	M12	23	20	31.5	25	202	101	21	54	50	40	25	13	32.5	22	12.5	127	12	236
11157	HCX.127-E-STL-NC-M12	127	M12	23	20	31.5	25	202	101	21	54	50	40	25	13	32.5	22	12.5	127	12	236
11158	HCX.254-E-STL-NO-M12	254	M12	23	20	31	25	328	228	21	54	50	40	25	13	32.5	22	12.5	254	12	263
11159	HCX.254-E-STL-NC-M12	254	M12	23	20	31	25	328	228	21	54	50	40	25	13	32.5	22	12.5	254	12	263

Maximum tightening torque.

