



Model Number

OMH-K02

dove tail mounting clamp

Features

- Mounting clamp
- Simple and fast mounting

Dimensions

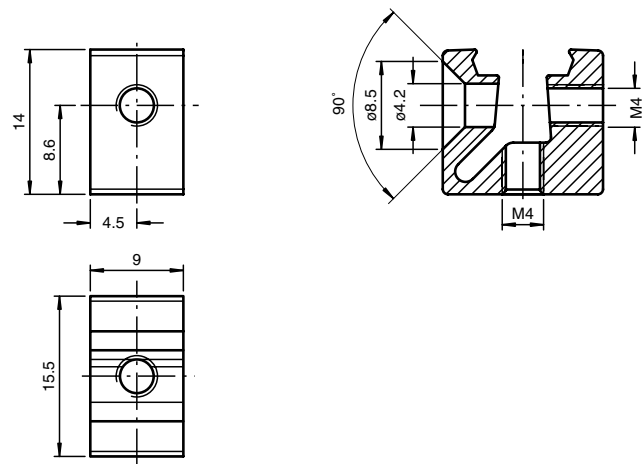

Technical data

Mechanical specifications

Material	anodized aluminum
Mass	approx. 5 g

Suitable series

Series	MLV12
Safety Series	SL12, SLA12