

Electraflow Plus[™] COMBI 600ml

A single component battery powered bead applicator for cartridges & sachets

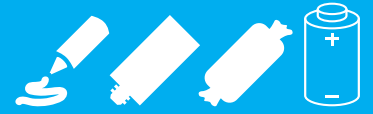

Rubber rest pads to prevent tool from slipping off worktops and to protect it when put down.

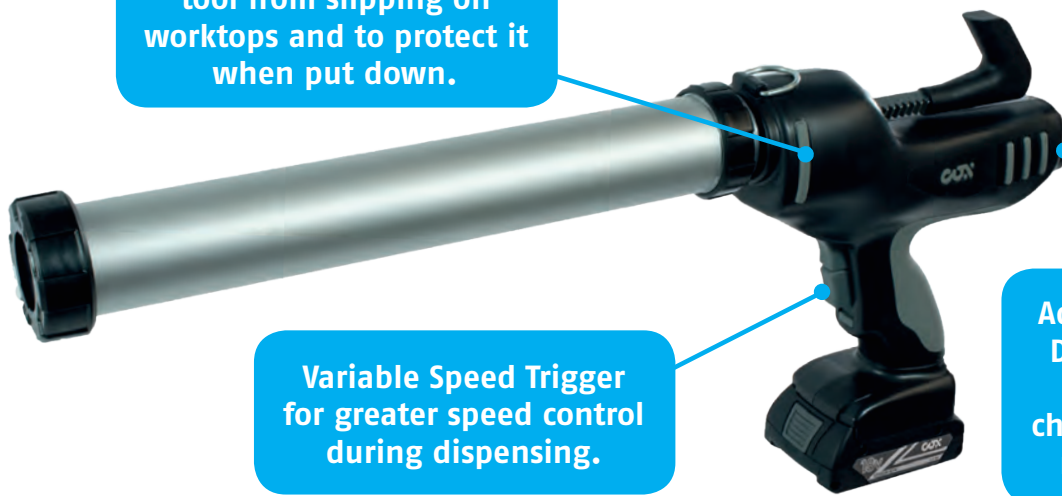

Variable Speed Trigger for greater speed control during dispensing.

Adjustable Speed Dial from 1(low) to 9(high) for choosing speed of material flow.

PRODUCT FEATURES:

- Adjustable Speed Dial from 1(low) to 9(high) for choosing speed of material flow.
- Variable Speed Trigger for greater speed control during dispensing. Very useful for inexperienced operators.
- Maximum rack speed of 8.0mm/sec which gives higher material output.
- Sophisticated tool control to protect mechanical parts and tool electronics under high load conditions (3.5kN).
- Rubber overmouldings for improved grip and comfort.
- Rubber rest pads to prevent tool from slipping off worktops and to protect it when put down.
- Auto-reverse function to stop material flow when trigger is released.
- Rapid battery charge; within 30mins (0-100%).
- Universal charger for worldwide use.
- Rotating aluminium barrel that accommodates both sachets and cartridges. Easy to handle in tight spaces.
- Overload shut off function to prevent damage of the tool.
- Curved rod (ladder hook) for convenient tool storage.

The **Cox Electraflow Plus Combi** is part of a range of high-powered battery applicators. Designed for use with medium to high viscosity sealants and adhesives, the Electraflow Combi is ideal for professional and specialist trade users.

For more information call +44(0)1635 264500
Or visit www.pccox.co.uk



The original

TECHNICAL DATASHEET

Electraflow Plus™ COMBI 600ml

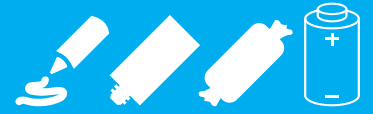

A single component battery powered bead applicator for cartridges & sachets

APPLICATIONS:

- For medium to high viscosity
- Cartridge/sachet: 1-component
- Cartridge volumes: 310ml & 400ml
- Sachet volumes: 310ml, 400ml & 600ml

SPECIFICATIONS:

- Voltage: 18v
- Battery Capacity (Ahr): 1.5 & 3.0
- Battery Charge Time: 30 minutes
- Battery Type: Li Ion
- Barrel Length: 382.51mm
- Max Force (Plunger): 3.5kN
- Tool Weight: 2.53kg (with 1.5Ah battery)
- Barrel Material: Anodised aluminium
- Handle Material: Base Moulding = Polycarbonate (PC)
Acrylnitrile-butadiene-styrene (ABS)
Soft Grip Overmould = Thermoplastics elastomers (TPE)
- Certificates: CE; IEC60335; UL, C-Tick, ISO, REACH
- Packaging Options: 1 per carton / plastic carry case

WEB LINKS:

- Images
www.pccox.co.uk/en/electraflowplus
- Academy video
www.pccox.co.uk/en/cox-academy
- Spare parts diagram
www.pccox.co.uk/en/exploded-diagrams

OTHER MODELS AVAILABLE:

- Electraflow Plus US Quart
- Electraflow Plus Floor Dispensers
- Electraflow Plus 2 component
- Electraflow Plus Cartridge

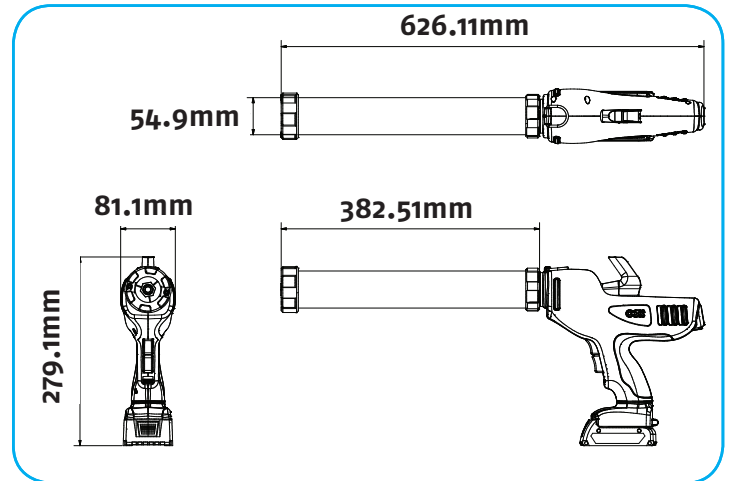

CARTRIDGES/SACHETS:

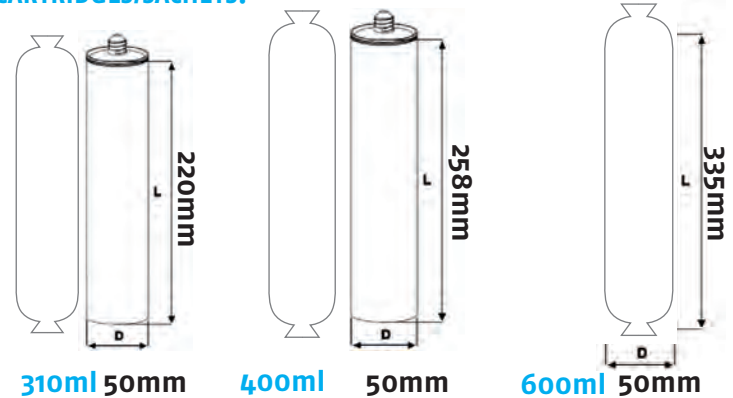

PRODUCT RANGE BY POWER:



PC Cox Ltd., Turnpike Road, Newbury, Berkshire, RG14 2LR
 T Sales +44 (0) 1635 264500 F +44 (0) 1635 264555
 E sales@pccox.co.uk
 www.pccox.co.uk



©PC Cox Ltd. 2016 Cox is a trademark of PC Cox Ltd. Every effort has been made to ensure that the information contained in this leaflet was correct at the time of going to press. However, the company retains the right to change any specification without notice, in line with the company's policy of continual product development.

