



Model Number

NBB1,5-F79-E3-5M

Features

- 1.5 mm flush
- 3-wire DC

Technical Data

General specifications

Switching element function		PNP	NC
Rated operating distance	s_n	1.5 mm	
Installation		flush	
Output polarity		DC	
Assured operating distance	s_a	0 ... 1.215 mm	
Reduction factor r_{Al}		0.3	
Reduction factor r_{Cu}		0.2	
Reduction factor r_{304}		0.7	

Nominal ratings

Operating voltage	U_B	5 ... 30 V DC
Switching frequency	f	0 ... 1200 Hz
Hysteresis	H	typ. 5 %
Short-circuit protection		pulsing
Voltage drop	U_d	≤ 1.5 V
Operating current	I_L	0 ... 100 mA
Off-state current	I_r	≤ 10 μ A
No-load supply current	I_0	≤ 15 mA
Time delay before availability	t_v	≤ 20 ms

Ambient conditions

Ambient temperature	-25 ... 70 °C (-13 ... 158 °F)
---------------------	--------------------------------

Mechanical specifications

Connection type	cablc PVC , 5 m
Core cross-section	3 x 0.09 mm ²
Housing material	PA
Sensing face	PA
Degree of protection	IP67

Compliance with standards and directives

Standard conformity	
Standards	EN 60947-5-2:2007 IEC 60947-5-2:2007

Approvals and certificates

CCC approval	CCC approval / marking not required for products rated ≤ 36 V
--------------	--

Dimensions

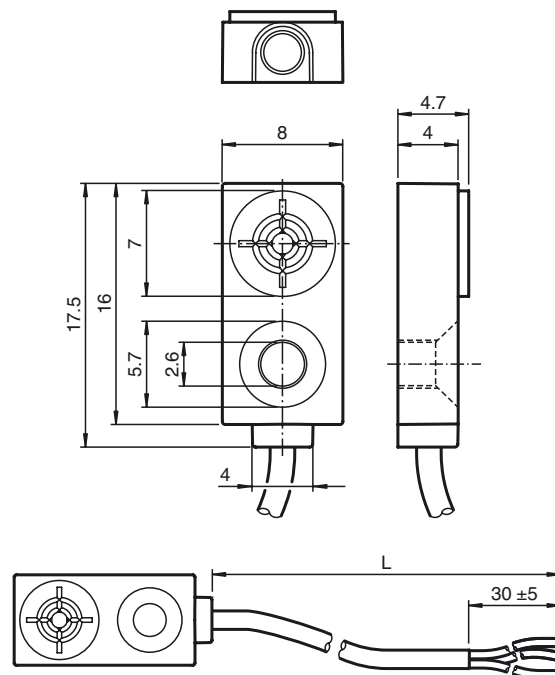

Electrical Connection

