

PRODUCT DATA SHEET / DATENBLATT

P/N 624 758 3 03

Crimping die set for use with the following hand tools or CM25 crimp machines
Crimpeinheit für folgende Handwerkzeuge oder CM25 Crimpmaschinen



P/N 624 000 6
P/N 624 000 3



P/N 6370 0100 1 (EU)
P/N 6370 0200 1 (GB)
P/N 6370 0300 1 (USA)



P/N 636 025-1
P/N 636 025-5
P/N 636 025-6

Description
Bezeichnung

Crimping die set 12.758

Crimpeinsatz 12.758

Image
Darstellung

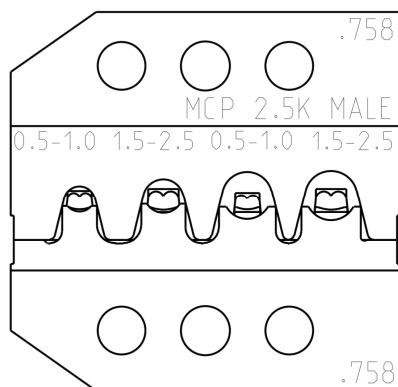

Capacity mm² or AWG
Kapazität mm² oder AWG

0,5 - 2,5 mm²
20 - 14 AWG

Application (contact P/N)
Anwendung (Kontaktnummer)

Contact description	Manufacturer	P/N-Strip	P/N-Loose	Type	Range
TAB 2.8 mm	Tyco Electronics	962841	963745	Male	0,50 - 1,00
TAB 2.8 mm	Tyco Electronics	962842	963746	Male	1,50 - 2,50
TAB 2.8 mm (EDS)	Tyco Electronics	962915	963748	Male	0,50 - 1,00
TAB 2.8 mm (EDS)	Tyco Electronics	962916	963749	Male	1,50 - 2,50

