

SKU:SEN0430 (<https://www.dfrobot.com/forum/>)

 (Product Link)

Introduction

The TMF8801 is a time-of-flight (ToF) distance ranging sensor that uses the time difference between light pulses to measure distance. It provides single zone detection of an object irrespective of the color, reflectivity and texture of the object. The TMF8801 offers high dynamic range and detection sensing measurements from 2-250cm distances. The device can make highly accurate distance measurements within $\pm 5\%$ and is capable of operation in dark environments and in the presence of sunlight. A built-in histogram is featured to delivers dynamic cover glass calibration and crosstalk compensation and background light noise is minimized through on-chip sunlight rejection filters. The TMF8801 outputs data through a I2C fast-mode communications

interface and an integrated micro controller, which is featured with all algorithms included on-chip with no need for external optics.

Features

- 21° FOI, detect the object closest to the center
- 20–2500mm distance sensing
- Enables dark and sunlight environment distance measurement within $\pm 5\%$
- A built-in histogram for compensating for dirt and smudges on cover glass
- 940nm VCSEL Class 1 Eye Safety
- Low power consumption, 940 μ A power consumption at 10Hz(proximity mode), 26mA power consumption at 60Hz (distance and proximity mode), 0.26 μ A power-down current consumption (EN=0)

Applications

- 3D face recognition
- Proximity detection
- Presence detection

- Presence detection
- Object detection
- Distance measurement
- Collision avoidance

Specification

- Operating Voltage: 2.7~3.3V
- Operating Current: <1.5mA
- Proximity Detection Range: 20-100mm
- Distance Sensing Range: 100-2500mm
- Operating Temperature: -30~60°C
- Communication Interface: Breakout 2.54mm-8Pin I2C
- Dimension: 21×14.5mm/0.83×0.57inch
- Mounting Hole Size: 2.0mm
- Mounting Hole Pitch: 17mm

Board Overview

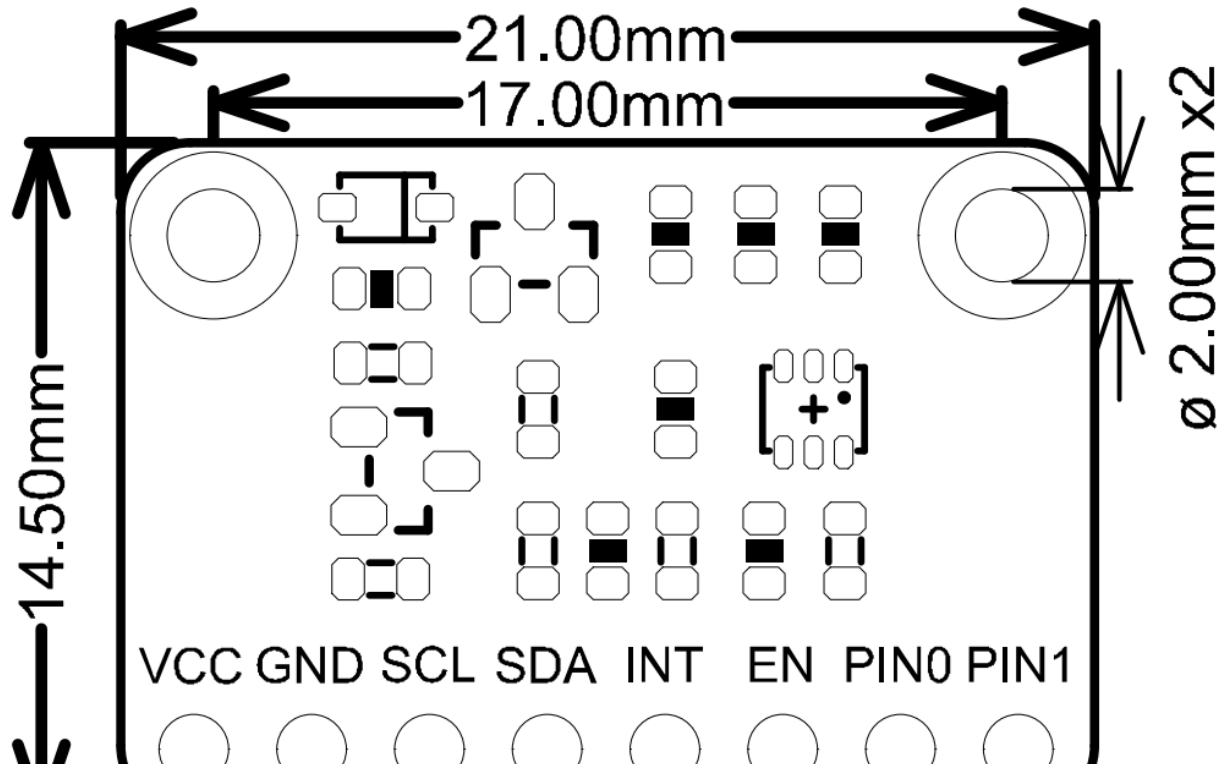



Name	Function
------	----------

VCC	+
GND	-
SCL	Clock line
SDA	Data line
INT	Alert Interrupt
EN	Reset
PIN0	Interrupt output pin0
PIN1	Interrupt output pin1

Tutorial

- **Hardware**
 - DFRduino UNO R3 (<https://www.dfrobot.com/product-838.html>) (or similar) x 1
 - TMF8801 Sensor x1
 - Jumper wires
- **Software**
 - Arduino IDE (<https://www.arduino.cc/en/Main/Software>)
 - Download and install the **TMF8×01 Library** (https://github.com/DFRobot/DFRobot_TMF8x01) (About how to install the library? (<https://www.arduino.cc/en/Guide/Libraries#.UxU8mdzF9H0>))
- API Functions

```

int begin();

/**
 * @brief sleep sensor by software, the sensor enter sleep mode(bootloader). Need to call
 */
void sleep();
/**
 * @brief wakeup device from sleep mode, it will running app0
 * @return enter app0 return true, or return false.
 */
bool wakeup();

/**
 * @brief get a unique number of sensor .Each sensor has a unique identifier.
 * @return return 4bytes unique number:
 * @n the byte0 of return: serial_number_0
 * @n the byte1 of return: serial_number_1
 * @n the byte2 of return: identification_number_1
 * @n the byte3 of return: identification_number_0

```

```

    * @param the bytes of return: identification_number_0
    */
    uint32_t getUniqueID();
/**
 * @brief get sensor's model.

 * @return return a String:
 * @n TMF8801: the sensor is TMF8801
 * @n TMF8701: the sensor is TMF8701
 * @n unknown : unknown device
 */
    String getSensorModel();
/**
 * @brief get software version of patch.
 * @return return string of device software version,format:
 * @n major.minor.patch numbers.chip id version
 */
    String getSoftwareVersion();
/**
 * @brief Get 14 bytes of calibration data.
 * @param data Cache for storing calibration data
 * @param len The bytes of calibration data,its value can only be 14 bytes
 * @return Vail data return true, or return false.
 */
    bool getCalibrationData(uint8_t *data, uint8_t len = SENSOR_MTF8x01_CALIBRATION_SIZE);
...

```



```

/**
 * @brief set 14 bytes of calibration data.
 * @param data Pointer to calibration data.
 * @param len The bytes of calibration data,its value can only be 14 bytes
 * @return set sucess return true, or return false.
 */
bool setCalibrationData(uint8_t *data, uint8_t len = SENSOR_MTF8x01_CALIBRATION_SIZE);

/**
 * @brief disable measurement config. Need to call startMeasurement before using this func
 */
void stopMeasurement();

/**
 * @brief Waiting for data ready.
 * @return if data is valid, return true, or return false.
 */
bool isDataReady();

/**
 * @brief get distance, unit mm. Before using this function, you need to call isDataReady()
 * @return return distance value, unit mm.
 */
uint16_t getDistance_mm();

/**
 * @brief enable INT pin. If you call this function,which will report a interrupt
 * @return return true if success, or return false.
 */
bool enableInterrupt();

```

```

* @n signal to host by INT pin when measure data is ready.
*/
void enableIntPin();
/**
* @brief disable INT pin.
*/
void disableIntPin();
/**
* @brief power on sensor when power down sensor by EN pin.
* @return success return True, or return False
*/
bool powerOn();
/**
* @brief power down sensor by EN pin.
* @return success return True, or return False
*/
bool powerDown();

/**
* @brief get I2C address.
* @return return 7 bits I2C address
*/
uint8_t getI2CAddress();
/**
* @brief get I2C address.
*/

```

```
^ @brief Config the pin of sensor.
* @param pin: The pin of sensor, example PIN0 and PIN1,which is an enumerated variable of
* @n     ePIN0: The PIN0 of sensor config.
* @n     ePIN1: The PIN1 of sensor.
* @n     eGPIONTotal: both of PIN0 and PIN1.

* @param config: The config of pin, which is an enumerated variable of ePinControl_t.
*/
void pinConfig(ePin_t pin, ePinControl_t config);
```

Connection Diagram

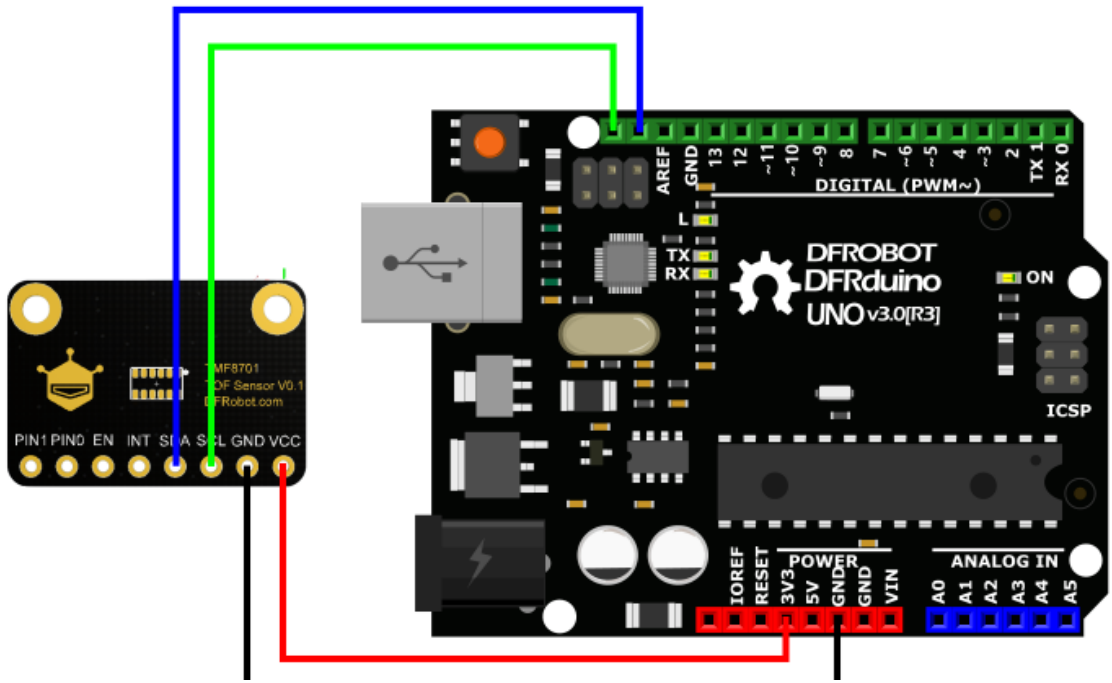



Sample Code 1 - Distance Detection

```

/ * !
* @file getDistance.ino
* @brief Get measurement data by PROXIMITY and DISTANCE hybrid mode.
* @n note: TMF8801 only suport one mode, PROXIMITY and DISTANCE hybrid mode.
* *

```

```

* Ranging mode configuration table:

```

```

* -----|
* | Type      | suport ranging mode | ranging ranges | Accuracy |
* |-----|-----|-----|-----|
* | TMF8801   | PROXIMITY and DISTANCE |                | 20~100mm: +/-15mm |
* |           | hybrid mode(only one) | 20~240cm      | 100~200mm: +/-10mm |
* |           |                         |                | >=200: +/-%5      |
* |-----|-----|-----|-----|
* |           | PROXIMITY mode       | 0~10cm        | >=200: +/-%5      |
* |           |-----|-----|-----|
* | TMF8701   | DISTANCE mode        | 10~60cm       | 100~200mm: +/-10mm |
* |           |-----|-----|-----|
* |           | PROXIMITY and DISTANCE | 0~60cm        |                |
* |           | hybrid mode          |                |                |

```



```

^ @url https://github.com/DFROBOT/DFROBOT_TMF8x01
*/

#include "DFRobot_TMF8x01.h"

#define EN      -1                //EN pin of of TMF8x01 module is floating, not us
#define INT     -1                //INT pin of of TMF8x01 module is floating, not u

DFRobot_TMF8801 tof(/*enPin =*/EN,/*intPin=*/INT);
//DFRobot_TMF8701 tof(/*enPin =*/EN,/*intPin=*/INT);

uint8_t caliDataBuf[14] = {0x41,0x57,0x01,0xFD,0x04,0x00,0x00,0x00,0x00,0x00,0x00,0x00,0x00,0x00,0x00};
void setup() {

    Serial.begin(115200);                //Serial In
    while(!Serial){                    //Wait for
    }

    Serial.print("Initialization ranging sensor TMF8x01.....");
    while(tof.begin() != 0){                //Initializatio
        Serial.println("failed.");
        delay(1000);
    }
    Serial.println("done.");
}

```



```

Serial.print("Software Version: ");
Serial.println(tof.getSoftwareVersion());
Serial.print("Unique ID: ");
Serial.println(tof.getUniqueID(),HEX);

Serial.print("Model: ");
Serial.println(tof.getSensorModel());

tof.setCalibrationData(caliDataBuf, sizeof(caliDataBuf));           //Set calibration data

/**
 * @brief Config measurement params to enable measurement. Need to call stopMeasurement to
 * @param cailbMode: Is an enumerated variable of eCalibModeConfig_t, which is to configure
 * @n   eModeNoCalib   :           Measuring without any calibration data.
 * @n   eModeCalib     :           Measuring with calibration data.
 * @n   eModeCalibAndAlgoState : Measuring with calibration and algorithm state.
 * @param disMode : the ranging mode of TMF8701 sensor.(this mode only TMF8701 support)
 * @n   ePROXIMITY: Raing in PROXIMITY mode,ranging range 0~10cm
 * @n   eDISTANCE: Raing in distance mode,ranging range 10~60cm
 * @n   eCOMBINE: Raing in PROXIMITY and DISTANCE hybrid mode,ranging range 0~60cm
 */
tof.startMeasurement(/*cailbMode =*/tof.eModeCalib);           //Enable measuring
//tof.startMeasurement(/*cailbMode =*/tof.eModeCalib, /*disMode =*/tof.ePROXIMITY);
}

```

```
void loop() {  
  if (tof.isDataReady()) {                                //Is check meas  
    Serial.print("Distance = ");  
    Serial.print(tof.getDistance_mm());                  //Print measure  
  
    Serial.println(" mm");  
  }  
}
```

Expected Results

The sensor provides detection range of 0~2500cm. It outputs 0 when out of range.

Note: The measured data may not be accurate in 0-20mm and 240cm-20cm.

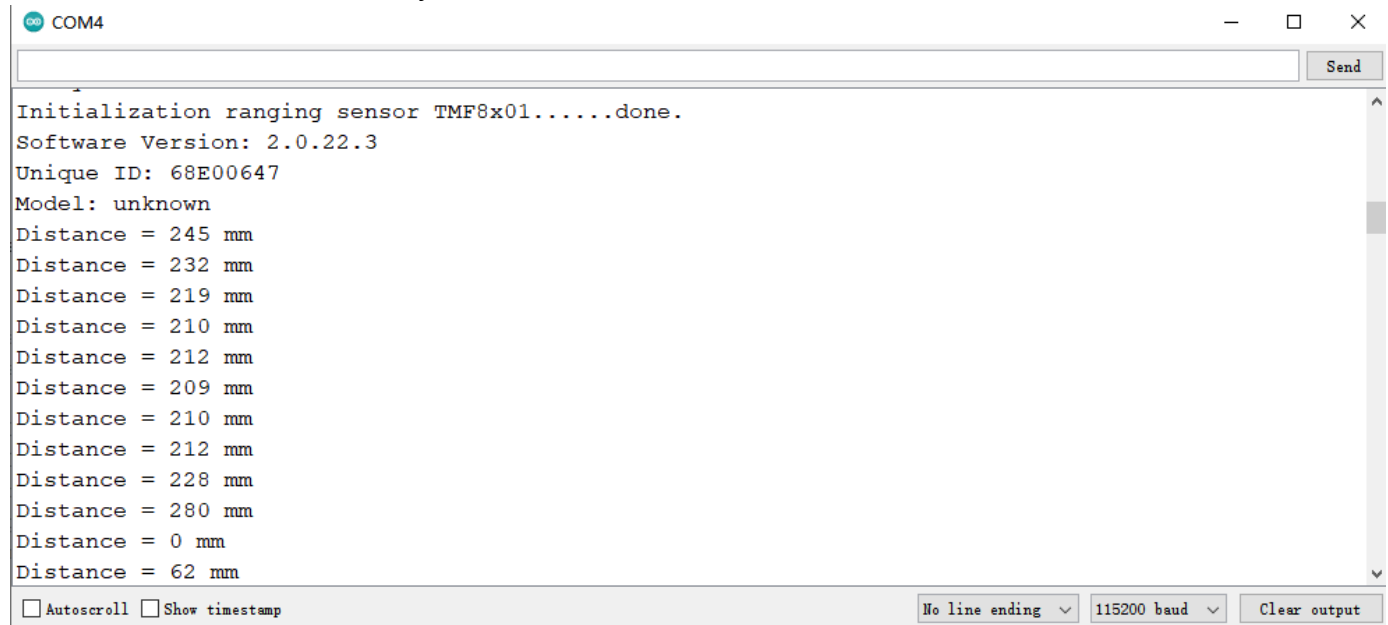

The screenshot shows a serial terminal window with the title 'COM4'. The window contains the following text:

```
Initialization ranging sensor TMF8x01.....done.  
Software Version: 2.0.22.3  
Unique ID: 68E00647  
Model: unknown  
Distance = 245 mm  
Distance = 232 mm  
Distance = 219 mm  
Distance = 210 mm  
Distance = 212 mm  
Distance = 209 mm  
Distance = 210 mm  
Distance = 212 mm  
Distance = 228 mm  
Distance = 280 mm  
Distance = 0 mm  
Distance = 62 mm
```

At the bottom of the window, there are several controls: a checkbox for 'Autoscroll', a checkbox for 'Show timestamp', a dropdown menu for 'No line ending', a dropdown menu for '115200 baud', and a 'Clear output' button.

Sample Code 2 - Interrupt Output

You can connect the INT of TMF8x01 to the MCU's external interrupt pin. When there is data output from the sensor, the INT will generate a LOW level and MCU can determine the coming data by detect that low level.

```

/ * !
* @file interrupt.ino
* @brief If you enable INT pin, MCU will capture a interrupt signal when the measure is c
* @n You can attach the INT pin of TMF8x01 to MCU external interrupt pin.
* @n When there is data output from the sensor, the INT will generate a LOW level and MCU
* *
* Ranging mode configuration table:
* TMF8X01_MODE_PROXIMITY: PROXIMITY mode
* TMF8X01_MODE_DISTANCE: DISTANCE mode
* TMF8X01_MODE_COMBINE: PROXIMITY and DISTANCE hybrid mode
* default mode: TMF8X01_MODE_COMBINE
*
* -----|
* | Type      | suport ranging mode | ranging ranges | Accuracy |
* |-----|-----|-----|-----|
* | TMF8801   | PROXIMITY and DISTANCE |                | 20~100mm: +/-15mm |
* |           | hybrid mode(only one) | 20~240cm       | 100~200mm: +/-10mm |
* |           |                       |                 | >=200: +/-%5      |
* |-----|-----|-----|-----|
* |           | PROXIMITY mode      | 0~10cm         |                   |

```

*		PROXIMITY mode	0~10cm	
*		-----	-----	>=200: +/-%5
*	TMF8701	DISTANCE mode	10~60cm	100~200mm: +/-10mm
*		-----	-----	
*		PROXIMITY and DISTANCE	0~60cm	
*		hybrid mode		
*		-----	-----	-----
*	*			

* @n hardware conected table:

*	-----		
*	TMF8x01	MCU	
*	-----		
*	I2C	I2C Interface	
*	-----		
*	EN	not connected, floating	
*	-----		
*	INT	to the external interrupt pin of MCU	
*	-----		
*	PIN0	not connected, floating	
*	-----		
*	PIN1	not connected, floating	
*	-----		

*

* @copyright Copyright (c) 2010 DFRobot Co.Ltd (<http://www.dfrobot.com>)

* 01: TMF8701 (TMF8701)

```
* @license The MIT License (MIT)
* @author [Arya](xue.peng@dfrobot.com)
* @version V1.0
* @data 2021-03-26
* @get from https://www.dfrobot.com

* @url https://github.com/DFRobot/DFRobot_TMF8x01
*/
```

```
#include "DFRobot_TMF8x01.h"
```

```
#define EN -1 //EN pin of of TM
#define INT 2 //connected INT p
```

```
DFRobot_TMF8701 tmf8x01(/*enPin =*/EN,/*intPin=*/INT);
//DFRobot_TMF8801 tmf8x01(/*enPin =*/EN,/*intPin=*/INT);
```

```
bool irqFlag = false;
void notifyFun(){
    irqFlag = true;
}
```

```
void setup() {
    Serial.begin(115200);
    while(!Serial){
```



```

/* Main-board of AVR series      Interrupt Pin vs Interrupt NO
* -----
* |                               | DigitalPin | 2 | 3 |
* | Uno, Nano, Mini, other 328-based |-----|
* |                               | Interrupt No | 0 | 1 |
* |-----|
* |                               | Pin       | 2 | 3 | 21 | 20 | 19 | 18
* |           Mega2560           |-----|
* |                               | Interrupt No | 0 | 1 | 2 | 3 | 4 | 5
* |-----|
* |                               | Pin       | 3 | 2 | 0 | 1 | 7 |
* | Leonardo, other 32u4-based   |-----|
* |                               | Interrupt No | 0 | 1 | 2 | 3 | 4 |
* |-----|
*/
/* microbit Interrupt Pin vs Interrupt NO
* -----
* |                               | DigitalPin | P0~P20 can be us
* |           microbit           |-----|
* |(when used as external interrupt, do not need to | Interrupt No | Interrupt NO is
* | set it to input mode via pinMode)           |               | the Interrupt NO
* |-----|
*/
attachInterrupt(/*Interrupt NO*/0,notifyFun,FALLING);

```



```
#endif

tmf8x01.startMeasurement(/*cailbMode =*/tmf8x01.eModeCalib);
//tmf8x01.startMeasurement(/*cailbMode =*/tmf8x01.eModeNoCalib);
//tmf8x01.startMeasurement(/*cailbMode =*/tmf8x01.eModeCalibAndAlgoState);

}

void loop() {
  if(irqFlag){
    irqFlag = false;
    if (tmf8x01.isDataReady()) {
      Serial.print("Distance = ");
      Serial.print(tmf8x01.getDistance_mm());
      Serial.println(" mm");
    }
  }
}
```

Expected Result

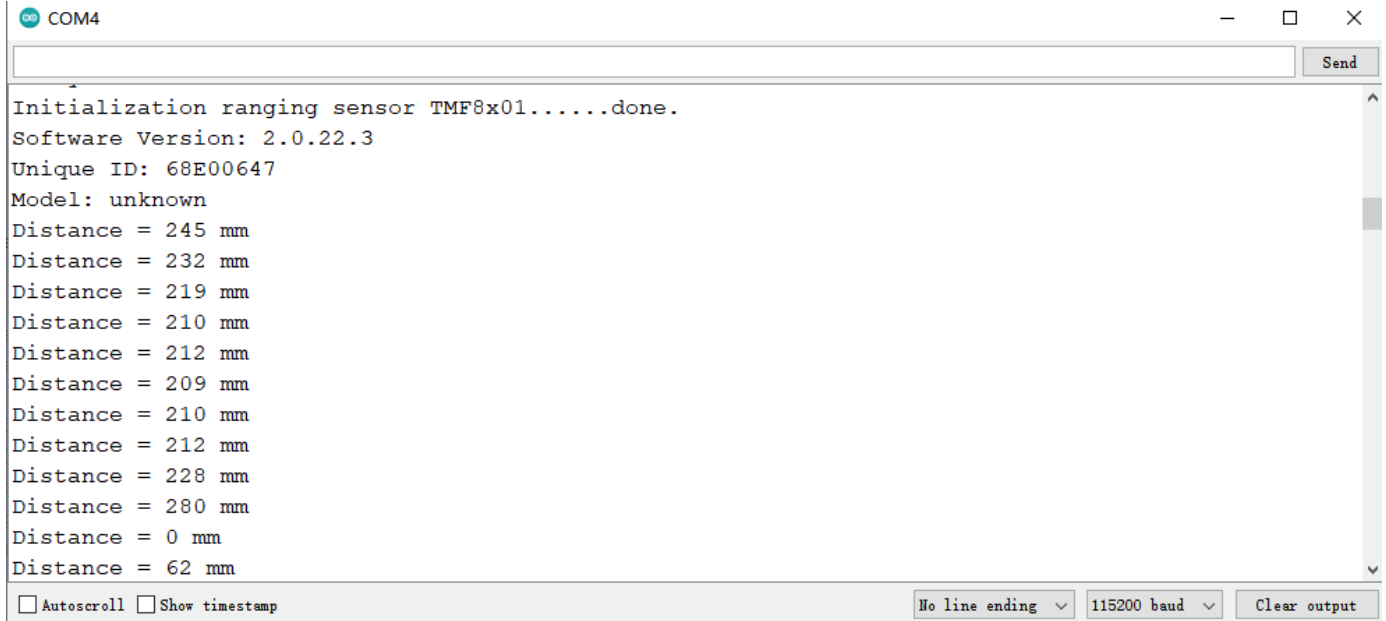

The screenshot shows a serial terminal window with the title 'COM4'. The window contains the following text output:

```
Initialization ranging sensor TMF8x01.....done.  
Software Version: 2.0.22.3  
Unique ID: 68E00647  
Model: unknown  
Distance = 245 mm  
Distance = 232 mm  
Distance = 219 mm  
Distance = 210 mm  
Distance = 212 mm  
Distance = 209 mm  
Distance = 210 mm  
Distance = 212 mm  
Distance = 228 mm  
Distance = 280 mm  
Distance = 0 mm  
Distance = 62 mm
```

At the bottom of the window, there are several controls: two checkboxes for 'Autoscroll' and 'Show timestamp', a dropdown menu for 'No line ending', a dropdown menu for '115200 baud', and a 'Clear output' button.

Sample Code - Sleep Mode

The sensor sleeps for 2s when finishing 20 measurements. In sleep mode, it stops ranging. We can activate it by wakeup function.

Note: it consumes 37.9mA current in ranging mode, 1.2mA in sleep mode.

```
/*!
 * @file sleep.ino
 * @brief The sensor sleeps for 2s when finishing 20 measurements. In sleep mode, it stops
 * @n note: it consumes 37.9mA current in ranging mode, 1.2mA in sleep mode.
 * *
 * Ranging mode configuration table:
 * TMF8X01_MODE_PROXIMITY: PROXIMITY mode
 * TMF8X01_MODE_DISTANCE: DISTANCE mode
 * TMF8X01_MODE_COMBINE: PROXIMITY and DISTANCE hybrid mode
 * default mode: TMF8X01_MODE_COMBINE
 * -----|
 * | Type      | support ranging mode | ranging ranges | Accuracy |
 * |-----|-----|-----|-----|
 * | TMF8801   | PROXIMITY and DISTANCE |                | 20~100mm: +/-15mm |
 * |           | hybrid mode(only one) | 20~240cm      | 100~200mm: +/-10mm |
 * |           |                         |                | >=200: +/-%5      |
 * |-----|-----|-----|-----|
 * |           | PROXIMITY mode        | 0~10cm        |                 |
 * |-----|-----|-----|-----|
```

*	TMF8701	DISTANCE mode	10~60cm	>=200: +/- % 100~200mm: +/-10mm
*		PROXIMITY and DISTANCE	0~60cm	
*		hybrid mode		

*-----
* *
* @n hardware conneted table:
*-----

*	TMF8x01	MCU
*	I2C	I2C Interface
*	EN	not connected, floating
*	INT	not connected, floating
*	PIN0	not connected, floating
*	PIN1	not connected, floating

* @copyright Copyright (c) 2010 DFRobot Co.Ltd (<http://www.dfrobot.com>)
* @licence The MIT License (MIT)

```

* @author [Arya](xue.peng@dfrobot.com)
* @version V1.0
* @data 2021-03-26
* @get from https://www.dfrobot.com
* @url https://github.com/DFRobot/DFRobot_TMF8x01

*/

#include "DFRobot_TMF8x01.h"

#define EN -1 //EN pin of of TMF8x01 module is floating, not us
#define INT -1 //INT pin of of TMF8x01 module is floating, not u

DFRobot_TMF8701 tmf8x01(/*enPin =*/EN,/*intPin=*/INT);
//DFRobot_TMF8801 tmf8x01(/*enPin =*/EN,/*intPin=*/INT);

#define NUM_OF_MEASUREMENT 20 //20 measur
#define SLEEP_TIME 2000 //sleep 200
uint8_t count = 0; //Measureme

void setup() {

  Serial.begin(115200); //Serial Ir
  while(!Serial){ //Wait for
  }

```

```

Serial.print("Initialization ranging sensor TMF8x01.....");
while(tmf8x01.begin() != 0){                                     //Initializ
    Serial.println("failed.");
    delay(1000);
}
Serial.println("done.");

Serial.print("Sensor Version info: ");
Serial.println(tmf8x01.getVersion());                           //Print ser

tmf8x01.startMeasurement(/*cailbMode =*/tmf8x01.eModeCalib);   //Enable me
//tmf8x01.startMeasurement(/*cailbMode =*/tmf8x01.eModeNoCalib); //Enable me
//tmf8x01.startMeasurement(/*cailbMode =*/tmf8x01.eModeCalibAndAlgoState); //Enable me
}

void loop() {
    if (tmf8x01.isDataReady()) {                                 //Is check
        Serial.print("Distance = ");
        Serial.print(tmf8x01.getDistance_mm());                 //Print mea
        Serial.println(" mm");
        count++;
    }
    if(count > NUM_OF_MEASUREMENT){

```

```
    count = 0;
    tmf8x01.sleep(); //sensor er
    Serial.println("sleep...");
    delay(SLEEP_TIME);
    Serial.println("wakeup...");

    tmf8x01.wakeup(); //wakeup ser
}
}
```

Expected Result



```
COM4
Distance = 43 mm
Distance = 44 mm
Distance = 43 mm
Distance = 43 mm
Distance = 44 mm
Distance = 43 mm
Distance = 43 mm
sleep...
wakeup...
Distance = 48 mm
Distance = 49 mm
Distance = 48 mm
```

```
Distance = 48 mm  
Distance = 48 mm  
Distance = 48 mm  
Distance = 49 mm  
Distance = 48 mm
```

Autoscroll Show timestamp

No line ending ▾

115200 baud ▾

Clear output

Sample Code 4 - Calibration Mode

The demo shows us how to obtain 14byte calibration and set calibration range.

Experiment condition: dark environment, no objects within 40cm around the sensor.

```

/!*
/!*
* @file calibration.ino
* @brief This demo tells how to get 14 bytes calibration, and how to set calibration range
* @n This demo application scenario: no target within 40cm of the sensor, in dark condition
* *
* Ranging mode configuration table:
* TMF8X01_MODE_PROXIMITY: PROXIMITY mode
* TMF8X01_MODE_DISTANCE: DISTANCE mode
* TMF8X01_MODE_COMBINE: PROXIMITY and DISTANCE hybrid mode
* default mode: TMF8X01_MODE_COMBINE
* -----|
* | Type      | support ranging mode | ranging ranges | Accuracy |
* |-----|-----|-----|-----|
* | TMF8801   | PROXIMITY and DISTANCE |                | 20~100mm: +/-15mm |
* |           | hybrid mode(only one) | 20~240cm       | 100~200mm: +/-10mm |
* |           |                       |                 | >=200: +/-%5 |
* |-----|-----|-----|-----|
* |           | PROXIMITY mode       | 0~10cm         |

```

*		PROXIMITY mode	0~10cm	
*		-----	-----	>=200: +/-%5
*	TMF8701	DISTANCE mode	10~60cm	100~200mm: +/-10mm
*		-----	-----	
*		PROXIMITY and DISTANCE	0~60cm	
*		hybrid mode		
*		-----	-----	-----
*	*			

* @n hardware conected table:

*	-----	
*	TMF8x01	MCU
*	-----	
*	I2C	I2C Interface
*	-----	
*	EN	not connected, floating
*	-----	
*	INT	not connected, floating
*	-----	
*	PIN0	not connected, floating
*	-----	
*	PIN1	not connected, floating
*	-----	

*

* @copyright Copyright (c) 2010 DFRobot Co.Ltd (<http://www.dfrobot.com>)

* 01: TMF8701 (TMF8701)

```
* @licence      The MIT License (MIT)
* @author [Arya](xue.peng@dfrobot.com)
* @version  V1.0
* @data  2021-03-26
* @get from https://www.dfrobot.com

* @url https://github.com/DFRobot/DFRobot_TM8x01
*/
```

```
#include "DFRobot_TM8x01.h"
```

```
#define EN      -1                //EN pin of of TM8x01 module is floating, not us
#define INT     -1                //INT pin of of TM8x01 module is floating, not u
```

```
DFRobot_TM8701 tmf8x01(/*enPin =*/EN,/*intPin=*/INT);
//DFRobot_TM8801 tmf8x01(/*enPin =*/EN,/*intPin=*/INT);
```

```
uint8_t calibrationDataBuffer[14] = {0x41,0x57,0x01,0xFD,0x04,0x00,0x00,0x00,0x00,0x00,0x00,0x00,0x00,0x00,0x00};
int distance = 0;
```

```
void setup() {
  Serial.begin(115200);
  while(!Serial){
  }
```

```
Serial.print("Initialization ranging sensor TMF8x01.....");
while(tmf8x01.begin() != 0){
    Serial.println("failed.");
    delay(1000);
}

Serial.println("done.");

Serial.print("Sensor Version info: ");
Serial.println(tmf8x01.getVersion());

/*
while(tmf8x01.getCalibrationData(calibrationDataBuffer, sizeof(calibrationDataBuffer))
    Serial.println("Get and print calibration data...");
    delay(1000);
}
Serial.println("Get and print calibration...sucess");
for(int i = 0; i < sizeof(calibrationDataBuffer); i++){
    Serial.print("0x");
    if(calibrationDataBuffer[i] < 16) Serial.print("0");
    Serial.print(calibrationDataBuffer[i]);
    Serial.print(",");
}
Serial.println();
*/
```

```
tmf8x01.setCalibrationData(calibrationDataBuffer, sizeof(calibrationDataBuffer));
tmf8x01.startMeasurement(/*cailbMode =*/tmf8x01.eModeCalib);
//tmf8x01.startMeasurement(/*cailbMode =*/tmf8x01.eModeCalibAndAlgoState);
}

void loop() {
  if (tmf8x01.isDataReady()) {
    Serial.print("Distance = ");
    Serial.print(tmf8x01.getDistance_mm());
    Serial.println(" mm");
  }
}
```

Expected Result

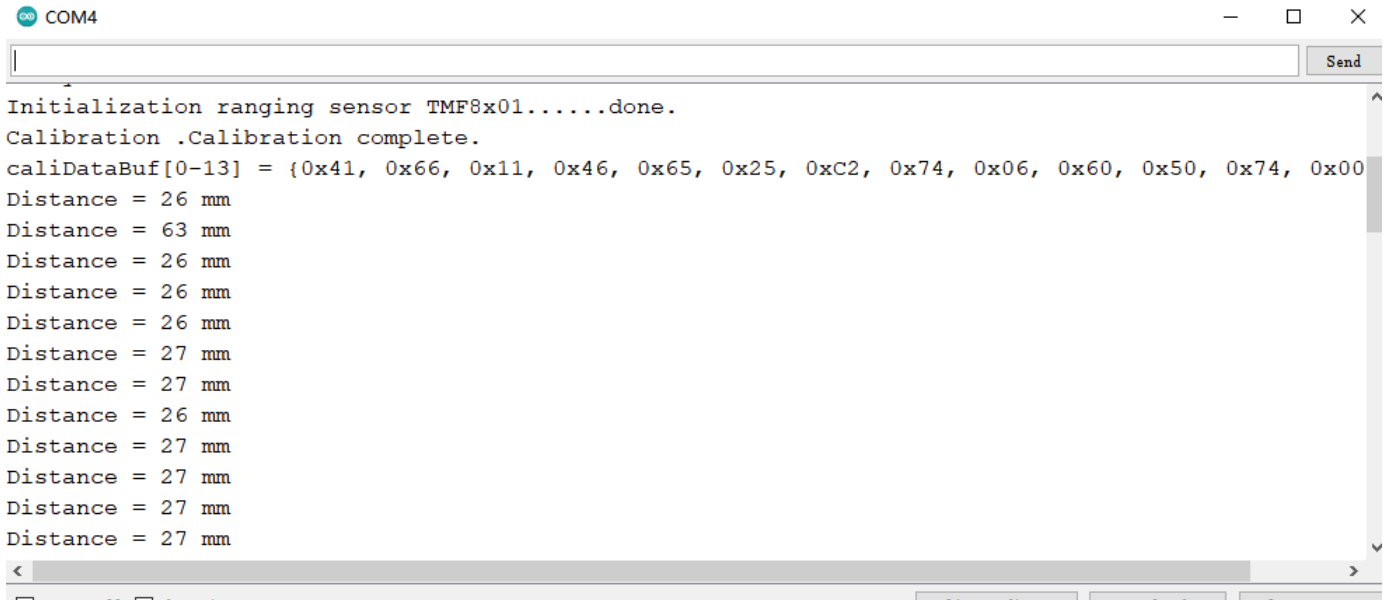

The image shows a screenshot of a terminal window titled "COM4". The window contains the following text:

```
Initialization ranging sensor TMF8x01.....done.  
Calibration .Calibration complete.  
caliDataBuf[0-13] = {0x41, 0x66, 0x11, 0x46, 0x65, 0x25, 0xC2, 0x74, 0x06, 0x60, 0x50, 0x74, 0x00  
Distance = 26 mm  
Distance = 63 mm  
Distance = 26 mm  
Distance = 26 mm  
Distance = 26 mm  
Distance = 27 mm  
Distance = 27 mm  
Distance = 26 mm  
Distance = 27 mm  
Distance = 27 mm  
Distance = 27 mm  
Distance = 27 mm  
Distance = 27 mm
```

The terminal window has a "Send" button in the top right corner and a scrollbar on the right side. The text is displayed in a monospaced font.

FAQ

For any questions, advice or cool ideas to share, please visit the **DFRobot Forum** (<https://www.dfrobot.com/forum/>).

More Documents

- [SEN0430]Schematics.pdf
(<https://dfimg.dfrobot.com/nobody/wiki/b0f134ac3d0f54b65e73272800deca05.pdf>)
- [SEN0430]datasheet.pdf
(<https://dfimg.dfrobot.com/nobody/wiki/eae83bd2ebe7cbf0c47a5833a045b644.pdf>)

 Get **Fermion: TMF8801 TOF Distance Ranging Sensor (20~2500mm)** (<https://www.dfrobot.com/product-203.html>) from DFRobot Store or **DFRobot Distributor**. (<https://www.dfrobot.com/index.php?route=information/distributorslogo>)

Turn to the Top