

HA13406W

Three-Phase Brushless Motor Driver

Description

The HA13406W power IC is developed for driving three-phase brushless motors. It provides hall effect sensor amps, logic, output amps, control amp, and forward and back rotation circuit functions on one chip. The maximum driving current and voltage is as much as 3A at 12V per phase. Therefore, it finds its best use driving the spindle motor of a 5.25 inch hard disk drive.

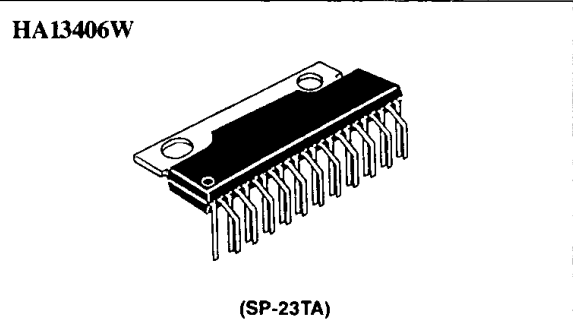

Features

- 3A output current capability
- Low output saturation voltage
- Hall effect amps with hysteresis
- Over temperature protection
- Low thermal resistance package

Ordering Information

Type No.	Package
HA13406W	SP-23TA

Block Diagram

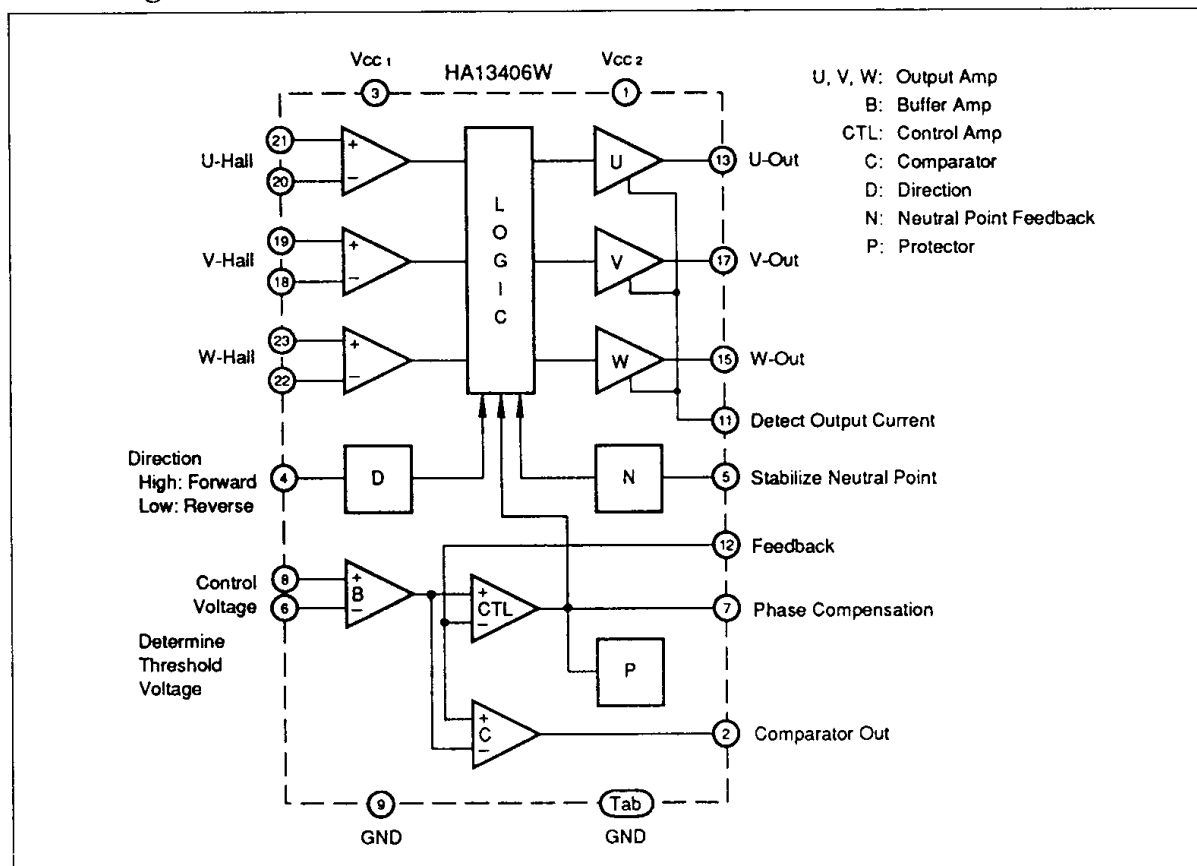

HA13406W

Application

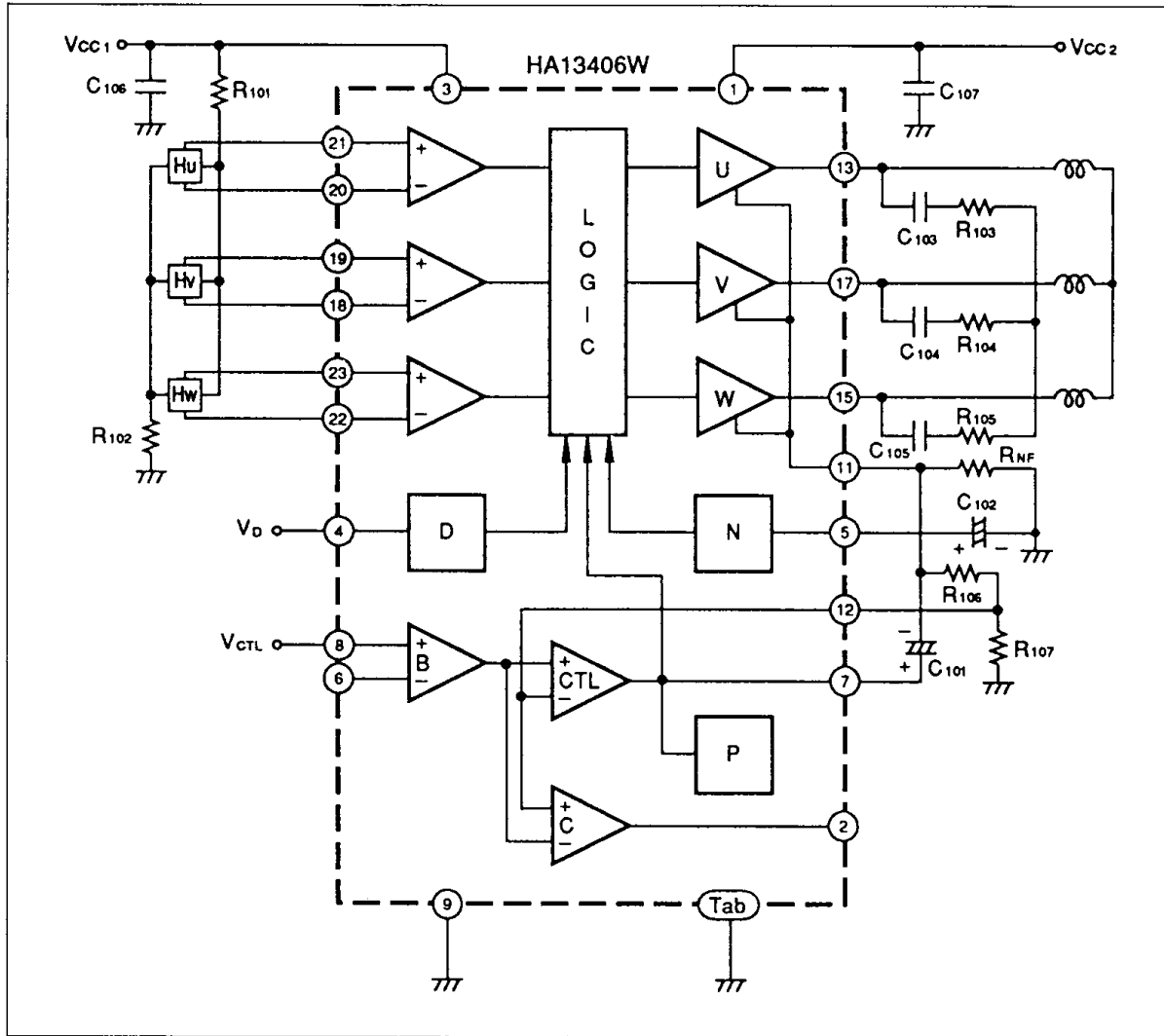

Figure 1 Linear Drive Circuit

Figure 1 and Table 1 show the HA13406W in a linear drive circuit.

The output stage is saturated at starting and is usually not saturated.

Therefore, the loss is comparatively large and a heat sink may be required.

The relationship between the current I_o , which flows into the motor coil, and the control voltage V_{CTL} is:

$$I_o = \frac{(R_{106} + R_{107})}{R_{107}} \frac{V_{CTL} - V_{Ref}}{R_{NF}} \dots\dots\dots(1)$$

where $V_{CTL} \geq V_{Ref}$

Here, V_{Ref} is the voltage at pin 6. It is set to $V_{cc1}/2$ internally.

Connecting the output of the servo IC to the terminal 8 constructs the servo driving system.

When $R_{106} = 0$, and $R_{107} = \infty$ (voltage gain of the control amp is 0dB), equation (1)

will be:

$$I_o = \frac{V_{CTL} - V_{Ref}}{R_{NF}} \dots\dots\dots(2)$$



Table 1 Linear Drive External Components

Part No.	Recommended value	Purpose
R101, R102	(Note 1)	Hall effect element bias
R103, R104, R105	10 Ω(1/4 W)	Stability
R106, R107	—	Determine the control amp gain
RNF	0.22 Ω (2 W)	Detect output current
C101	1 μF/16 WV	Control amp phase compensation
C102	10 μF/16 WV	Stabilizes the neutral point
C103, C104, C105	1 0μF/16 WV (Note 2)	Stability
C106	0.1μF	Power supply by-passing
C107	100 μF/16 WV	Power supply by-passing

Notes: 1. Set so that the input voltage of the hall effect amp (AC) will be more than 100mVpp.
 2. If the system is adversely affected by the spike voltage at commutation, make it larger (max 22μF).

High-Efficiency Drive

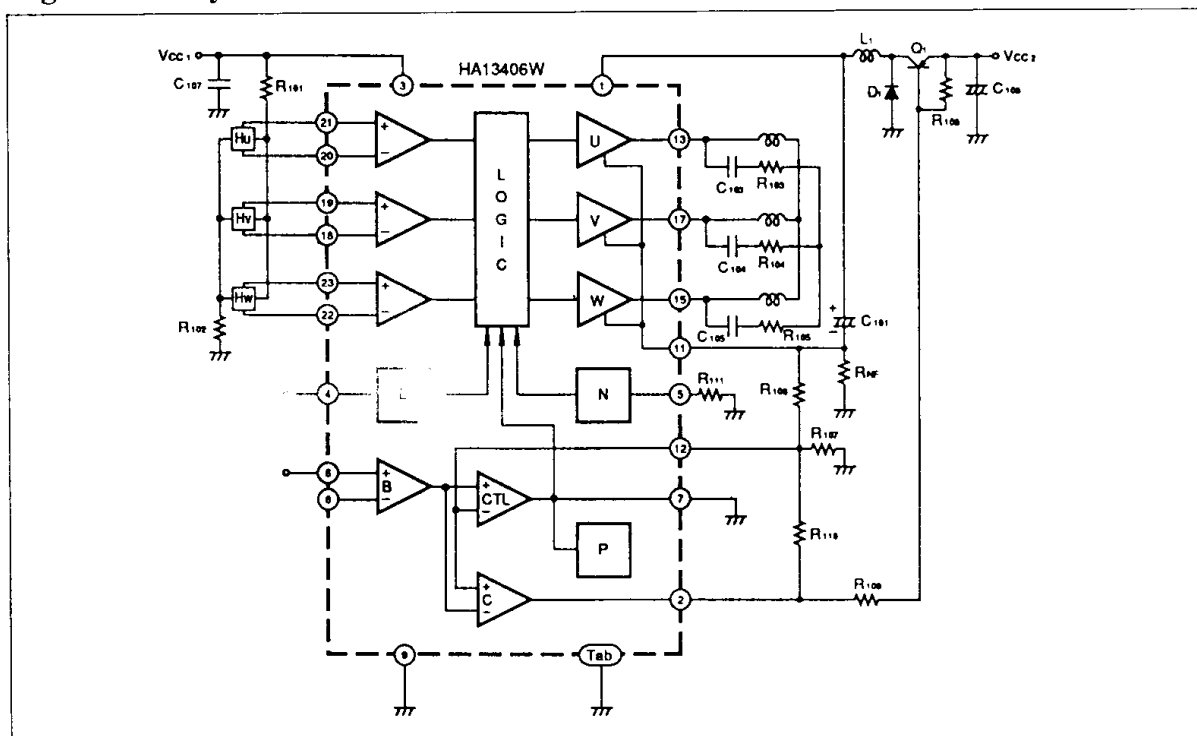

Figure 2 High-Efficiency Drive Circuit



HA13406W

Figure 2 and table 2 show the HA13406W in a high-efficiency drive circuit.

As the output stage is always saturated, the loss is less than in the linear drive application and the efficiency of the system may be increased.

The comparator C oscillates automatically and its on-off duty cycle is controlled by the control voltage V_{CTL} . Consequently, the on-off duty cycle of the external switching transistor Q1 is also controlled by V_{CTL} . That is called PWM (pulse width modulation) control of power supply, which means that one pin voltage of IC's is controlled.

The voltage which appears at current detection resistor R_{NF} feeds back to the comparator C, so that the relationship between the current which flows into the motor coil, I_o , and the control voltage V_{CTL} is also shown in the equation (1).

The automatic oscillating frequency f_c is mostly determined by the external constant on around the duty of 50%.

$$f_c = \frac{R_{NF} R_{110}}{4L_1 R_{106}} \dots\dots\dots(3)$$

f_c should be set in the range between 20 and 100kHz.

Table 2 High-Efficiency Drive External Components

Part No.	Recommended value	Purpose
R101, R102	—	Hall effect element bias
R103, R104, R105	10 Ω (1/4 W)	Stability (May be omitted if there is no oscillation)
R106, R107	—	Determine the control
R108	2.2 k Ω (1/4 W)	Prevents errors caused by leak current
R109	2.2 k Ω (1/4 W)	Limits comparator output current
R110	—	Determines the comparator hysteresis
R111	4.7 k Ω	Neutral point feedback circuit bias
R_{NF}	0.22 Ω (2 W)	Detect output current
C101	100 μ F/16 WV	Lowpass filter
C103, C104, C105	0.1 μ F	Stability (May be omitted if there is no oscillation)
C107, C108	0.1 μ F	Power supply by-passing
L1	1 mH	Lowpass filter
Q1	—	Switches power supply
D1	—	Flywheel diode



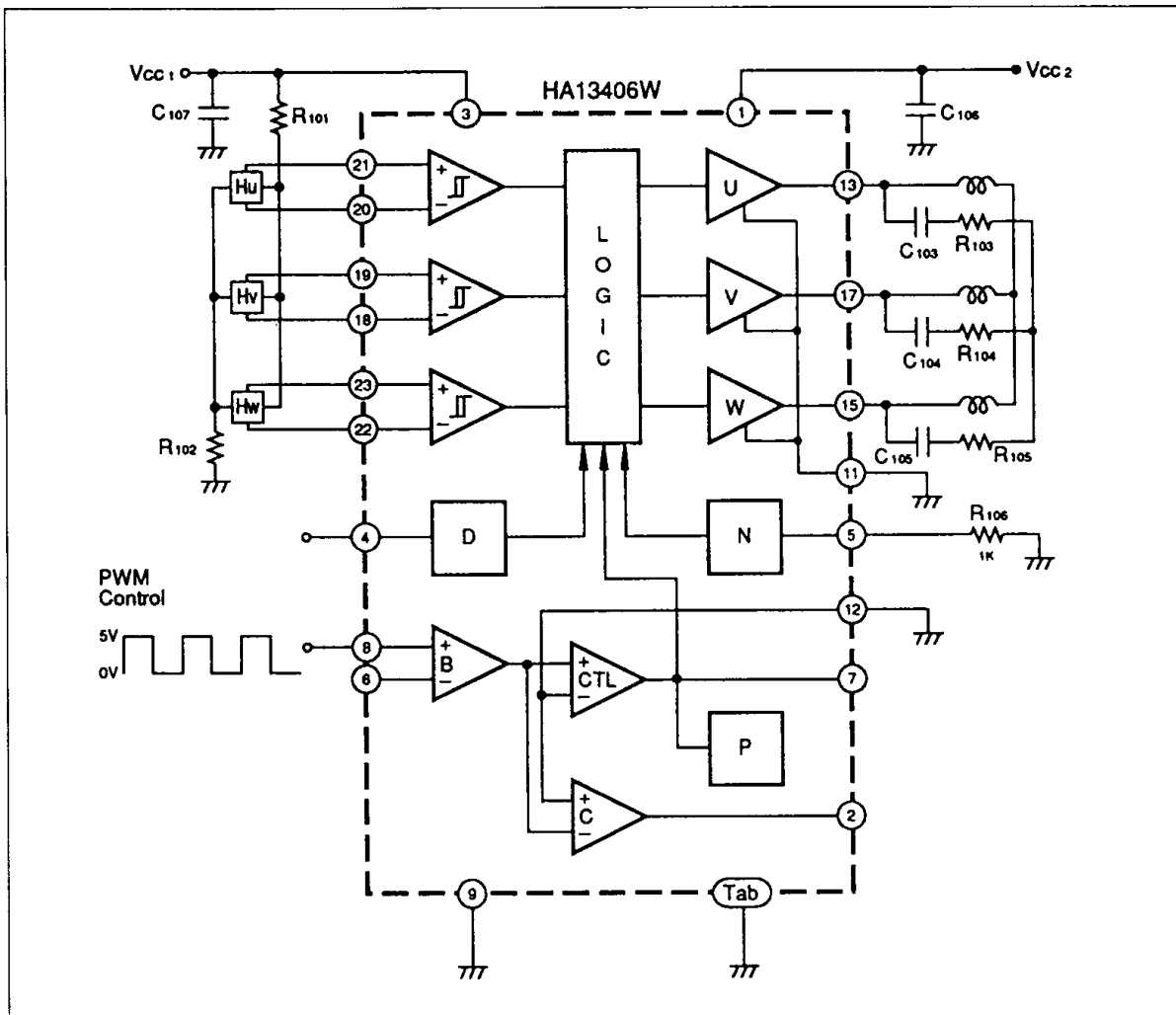

Figure 3 High-Frequency Drive Circuit

High-Frequency Drive

Figure 3 and table 3 show the HA13406W in a high-frequency drive circuit.

As the output stage is always saturated, the loss is less than in the linear drive application and the efficiency of the system may be increased.

In this application, output transistors are saturated or shut off. Output transistors switch on (saturate) at control input high, and switch off at the low state. That is, motor speed can be controlled by PWM.

The fundamental frequency should be in the range from 1kHz to 20kHz



HA13406W

Table 3 High-Frequency Drive External Components

Part No.	Recommended value	Purpose
R101, R102	—	Hall effect element bias
R103, R104, R105	10 Ω (1/4 W)	Stability (May be omitted if there is no oscillation)
R106	1 kΩ	Output stage bias
C103, C104, C105	0.1 μF	Stability
C106, C107	0.1 μF	Power supply by-passing

Table 4 Absolute Maximum Ratings (Ta=25 °C)

Item		Symbol	Ratings	Unit
Control stage supply voltage (note 1)		V _{CC1}	7	V
Output stage supply voltage (note 1)		V _{CC2}	15	V
Output current		I _o	3	A
Power dissipation		P _T	25	W
Thermal resistance	junction-case	θ _{j-c}	3.0	°C/W
	Junction-ambient	θ _{j-a}	40	
Hall effect amp input voltage		V _H	0 to V _{CC1}	V
Direction voltage		V _D	0 to V _{CC1}	V
Control voltage		V _{CTL}	0 to V _{CC1}	V
Junction temperature		T _j	150	°C
Operating junction temperature range		T _{jop}	-20 to +125	°C
Storage temperature range		T _{stg}	-55 to +125	°C

Note: 1. Recommended operating voltage

	Min	Typ	Max	Unit
V _{CC1}	4.5	5.0	5.5	V
V _{CC2}	10.2	12	13.8	V

The absolute maximum ratings are limiting values, to be applied individually, beyond which the device may be permanently damaged. Functional operation under any of these conditions is not guaranteed. Exposing a circuit to its absolute maximum rating for extended periods of time may affect the device's reliability.



Table 5 Electrical Characteristics (Ta=25°C, Vcc1=5V, Vcc2=12V)

Item		Min	Typ	Max	Unit	Test Conditions	Test Terminal
Total	Quiescent current	—	10	15	mA	V _{CTL} =0V V _{CC1}	3
		—	10	15	mA	V _{CC2}	1
		—	10	15	mA	V _{CTL} =V _{CC1} V _{CC1}	3
		—	105	150	mA	R _L =Open V _{CC2}	1
Thermal shut-down temperature (Note 1)		—	150	—	°C	V _{CTL} =V _{CC1} , I _o =0.1 A	
Hall effect amp to logic	Input bias current	—	—	±50	μA		18-23
	Input common-mode voltage range	2.0	—	3.0	V		18-23
	Hysteresis width	15	—	30	mV	R _G =220 Ω	18-23
Output	Sustaining voltage	15	—	—	V	I _c =20 mA	13, 15, 17
	Leak current	—	—	10	mA	V _{CE} =15 V	13, 15, 17
	Saturating voltage	—	2.8	3.8	V	V _{CTL} =V _{CC1} , I _o =2.8 A	13, 15, 17
Buffer	Internal reference voltage	2.35	2.5	2.65	V		6
	Output resistance of reference	—	2.5	—	kΩ		6
	Threshold voltage	—	100	—	mV	I _o =20 mA	8
	Input current	—	0	±10	μA	V _{CTL} =5 V	8
		—	-3	±10	μA	V _{CTL} =1 V	8
Voltage gain	—	0	—	dB	I _o =0.8 A, f=500 Hz	11	
Control amp	Input offset voltage	—	100	—	mV	I _o =20 mA	12
	Voltage gain	—	0	—	dB	I _o =0.8 A, f=500 Hz	11

HA13406W

Electrical Characteristics (Ta=25°C, Vcc1=5V, Vcc2=12V) (cont)

Compara-tor	Leak current	—	—	1.0	mA	V _{CE} =15 V	2
	Saturation voltage	—	1.0	1.5	V	I _c =20 mA	2
Direction	Voltage range for forward mode	2.0	—	5	V		4
	Voltage range for reverse mode	0	—	0.7	V		4
Input current		—	-1.2	—	mA	V _D =GND	4
		—	0	—	mA	V _D =5 V	4

- Notes:
1. Case temperature
 2. Sum of the upper and lower saturation voltage
 3. Reference to pin 6

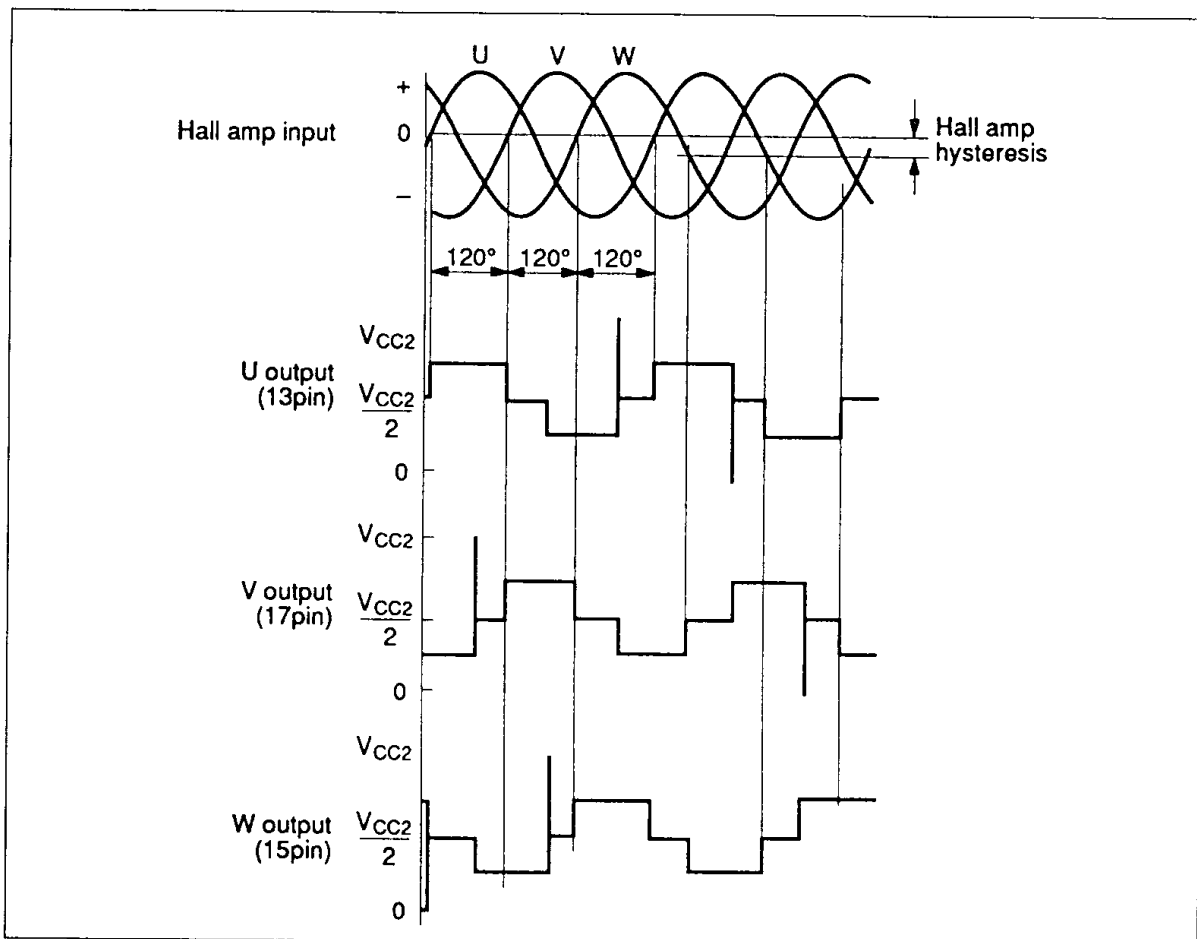

Figure 4 Timing Chart

