

## Configurable multi channel relay driver 2HS + 6HS/LS

### Features

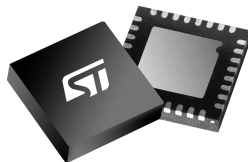

VFQFPN32 exposed pad down  
(5x5x1 mm)

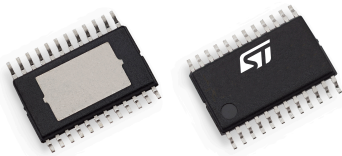

HTSSOP24 exposed pad down  
(7.8x6.4x1 mm)

- AEC-Q100 qualified 
- Six Configurable LS/HS drivers
- Two High Side drivers
- 2 parallel input pins with Input Mapping functionality
- Cranking capability down to VBATT = 3 V
- Digital supply voltage compatible with 3.3 V and 5 V microcontroller
- Reverse battery protection on VBATT and on drain pins without external components
- LED mode
- Bulb Inrush Mode (BIM) to drive lamps and electronic loads
- 2 Internal PWM Generator for microcontroller offload
- Very low quiescent current (with usage of IDLE pin)
- Limp Home mode (with usage of IDLE and IN pins)
- Green Product (RoHS compliant)
- Safety features
  - Temperature Sensor and Monitoring
  - Serial communications using address feedback, 1 parity bit, frame counter & short frame detection
- 16-bit serial peripheral interface for control and diagnosis
- Daisy Chain capability SPI, also compatible with 8-bit SPI devices
- Package options: HTSSOP24, VFQFPN32
- Full ISO26262 compliant, ASIL-B systems ready

#### Product status link

L9026

#### Product summary

Order code	L9026-B03N-TR
Package	VFQFPN32
Packing	Tape & Reel
Order code	L9026-YO-TR
Package	HTSSOP24
Packing	Tape & Reel

### Description

The **L9026** is an eight-channel IC, with 2 fixed HS drivers and 6 configurable HS/LS drivers designed for Automotive applications (LEDs and Relays) and compatible with resistive, inductive and capacitive loads. The device offers advanced diagnostic and protection functionalities such as: short to GND, open load, overcurrent, over-temperature detections. The 8 output channels can be either driven by SPI or by 2 dedicated parallel inputs. Limp home functionality is also featured, which allows using 2 selected drivers in particular faulty conditions, such as SPI fault, micro fault or supply UV. Daisy chain compatible even with 8bit SPI is available. The device is able to guarantee operations under cranking scenario down to VBATT = 3 V and guarantees very low quiescent current under RESET condition.

A serial peripheral interface (SPI) is used for control and configuration of the loads as well as of the device; besides, status feedback of all diagnostic functions is provided. For direct control and PWM there are two input pins available: these are connected to two defined outputs by default, but additional or different output mapping can be controlled by SPI.

As reported above the device is available in two package versions HTSSOP24 and VFQFPN32. Only for the QFN package 2 additional pins are available for safety reasons. In details, the NRES pin is used to reset internal registers to their default values and the DIS pin is used to disable all channels.

**1 Block diagram**

Figure 1. Block diagram

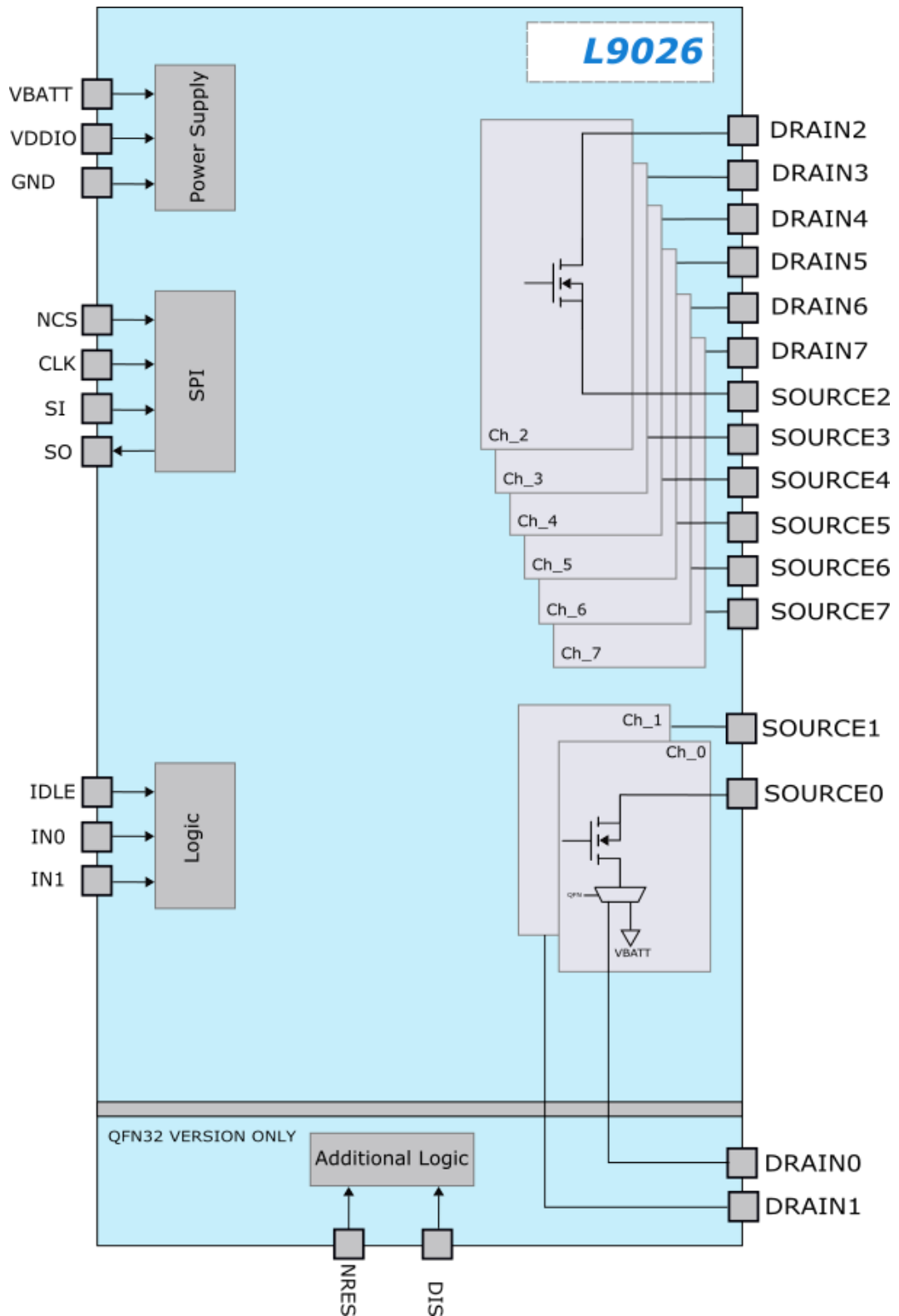

## 2 Application circuit

Here below two general application circuits:

- Figure 2 reports L9026 with the HTSSOP24 version package
- Figure 3 shows the application of L9026 with the VFQFPN32 version package

In the list of external components, the different parts are marked following the items reported below:

1. mandatory components for L9026 functionality
2. recommended components for EMC robustness
3. recommended components for ESD trials
4. recommended System component

*Note:* recommended components may depend on the requirements at system levels and shall be confirmed by specific tests on the final application.

Figure 2. HTSSOP24 Application schematic

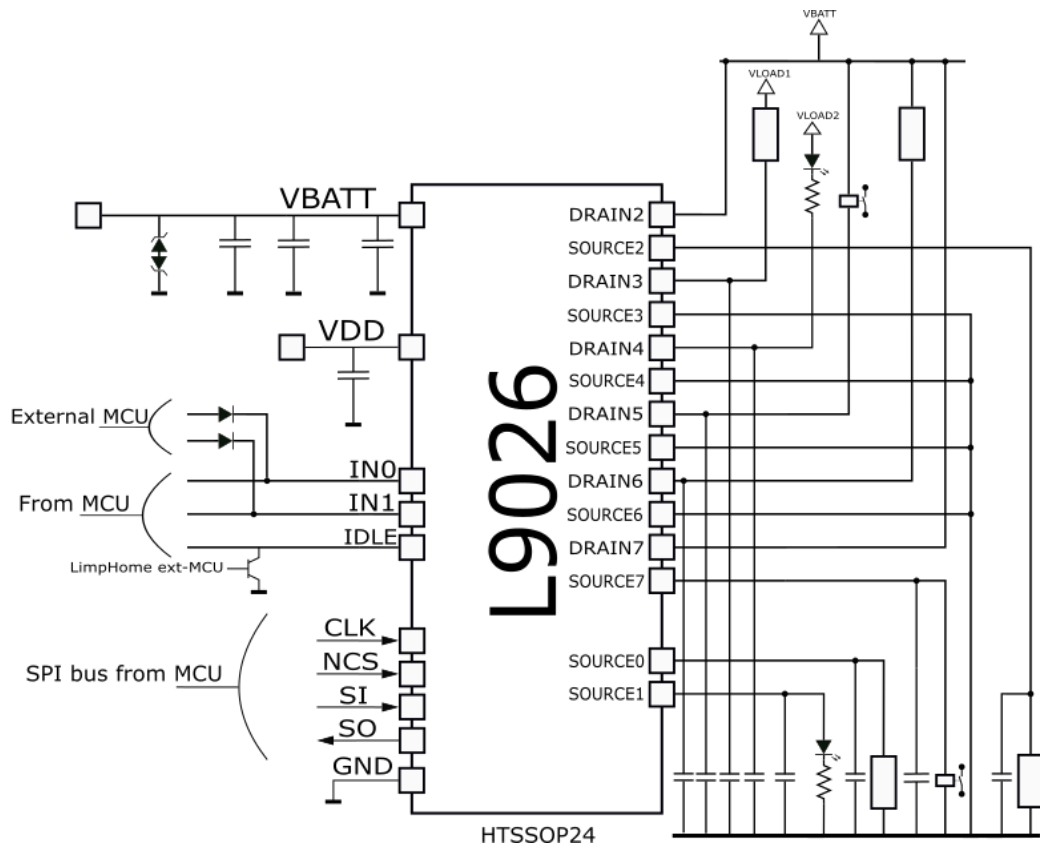

**Figure 3. VFQFPN32 Application schematic**

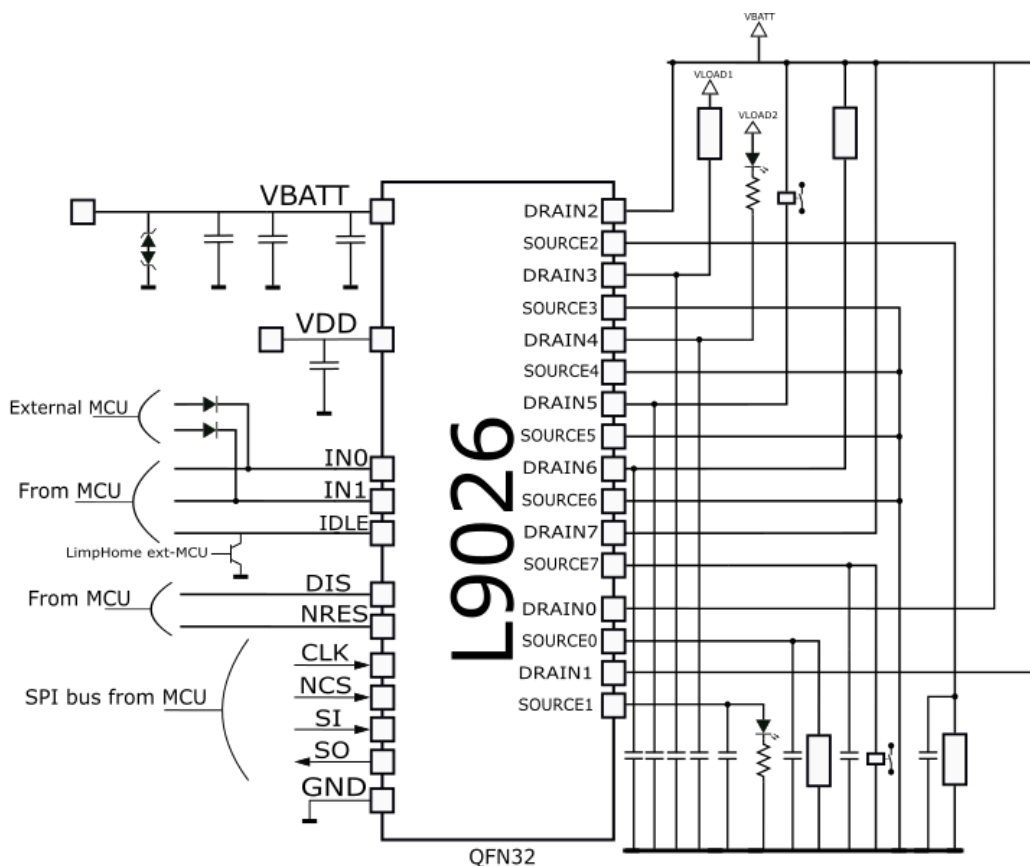
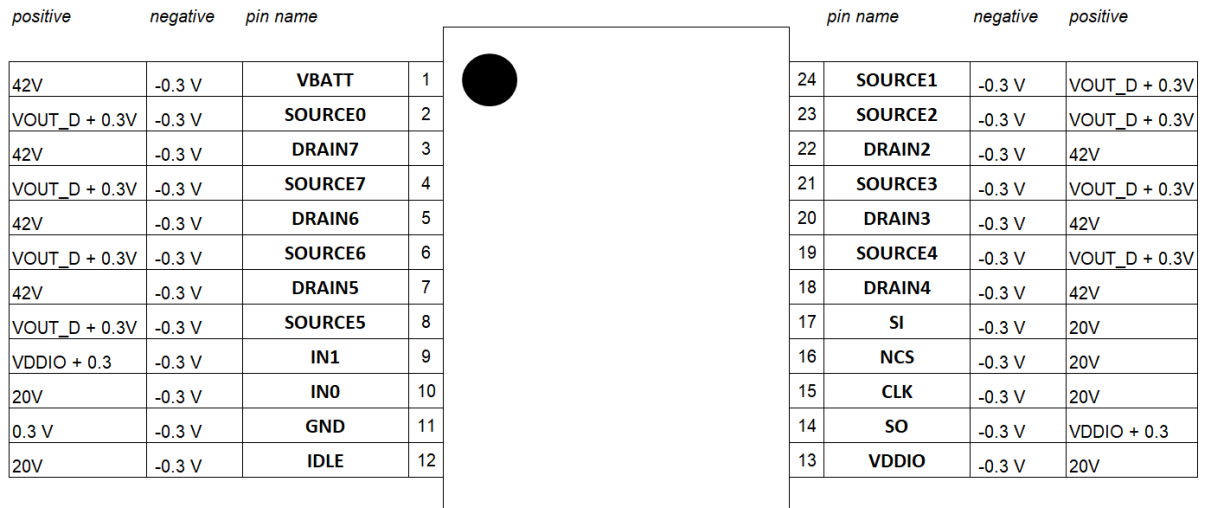

**Table 1. External components list for L9026 application circuit**

Pin	External components					Requirement	Comment
	Type	Min	Typ	Max	Unit		
VBATT	Capacitor	-	120	-	nF	(2), (3)	Tolerance ±20% 50 V
	Capacitor	-	100	-	µF	(2)	50 V, Transient and load dump protection
	TVS	- 15	-	38	V	(4)	Transient voltage suppressor
	Capacitor	-	10	-	µF	(2), (3)	Tolerance ±20% 50 V, Transient and load dump protection
VDDIO	Capacitor	-	100	-	nF	(2)	Tolerance ±10% 50 V
DRAIN2 DRAIN7		-	-	12		(3)	Maximum total capacitance value at output load (channel configured as low side)
DRAIN0 DRAIN7	Capacitor	47	-	-	nF	(4)	Minimum capacitance value at load supply (channel configured as high side, DRAIN0 and DRAIN1 if available)
SOURCE0 SOURCE7	Capacitor	-	-	12	nF	(3)	Maximum total capacitance value as output load (channel configured as high side)

### 3 Pins description

Figure 4. HTSSOP-24 pinout diagram

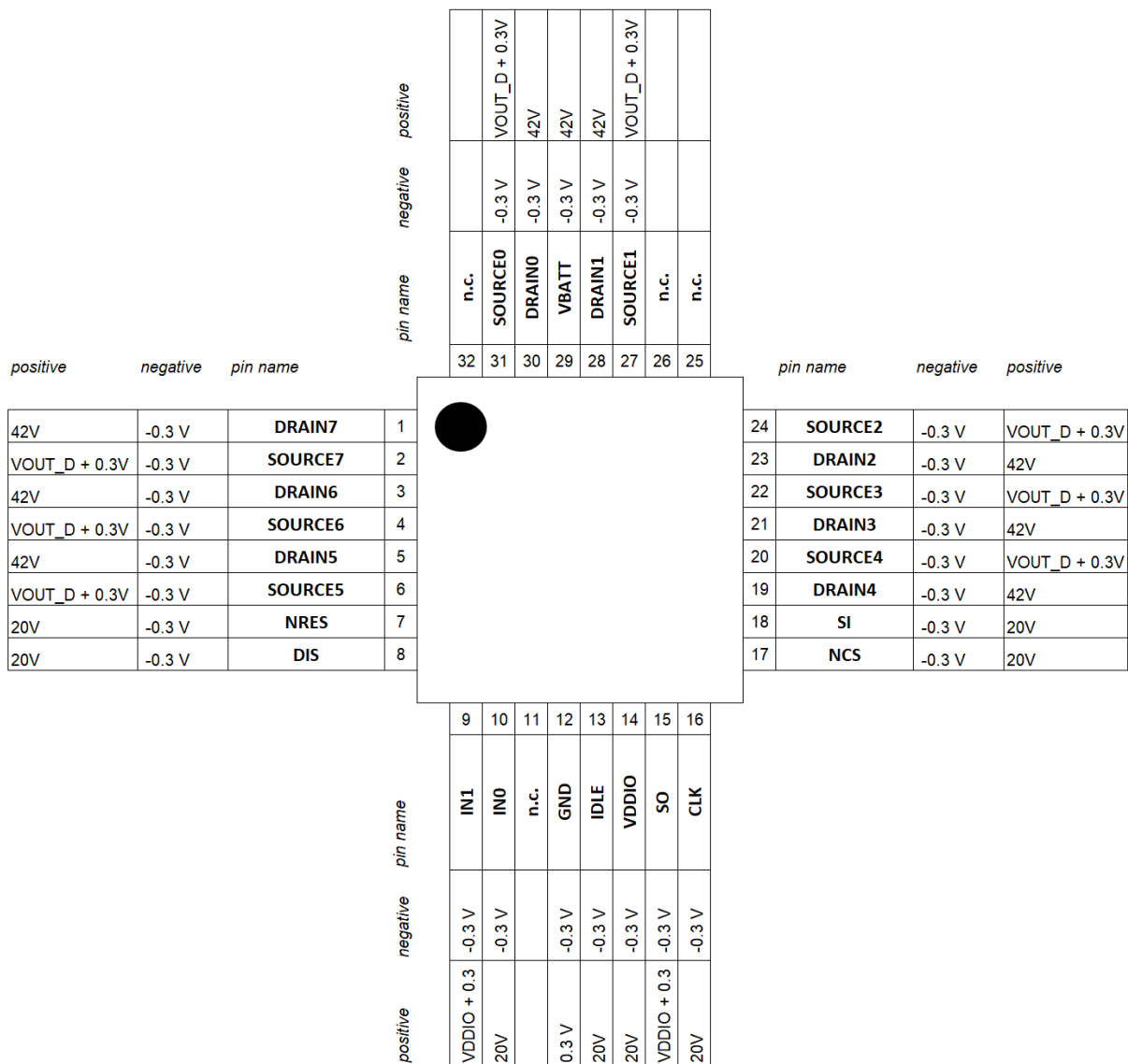

**Figure 5. VFQFPN32 pinout diagram**

**Table 2. HTSSOP-24 pins list**

Pin number	Symbol	Function
1	VBATT	Battery voltage
2	SOURCE0	HS Source 0
3	DRAIN7	LS/HS Drain 7
4	SOURCE7	LS/HS Source 7
5	DRAIN6	LS/HS Drain 6
6	SOURCE6	LS/HS Source 6
7	DRAIN5	LS/HS Drain 5
8	SOURCE5	LS/HS Source 5
9	IN1	Parallel command input 1
10	IN0	Parallel command input 0
11	GND	Ground pin
12	IDLE	Idle function
13	VDDIO	IO supply
14	SO	SPI output stream
15	CLK	SPI clock
16	NCS	SPI Chip Select
17	SI	SPI input stream
18	DRAIN4	LS/HS Drain 4
19	SOURCE4	LS/HS Source 4
20	DRAIN3	LS/HS Drain 3
21	SOURCE3	LS/HS Source 3
22	DRAIN2	LS/HS Drain 2
23	SOURCE2	LS/HS Source 2
24	SOURCE1	HS Source 1

**Table 3. VFQFPN32 pins list**

Pin number QFN32	Symbol	Function
1	DRAIN7	LS/HS Drain 7
2	SOURCE7	LS/HS Source 7
3	DRAIN6	LS/HS Drain 6
4	SOURCE6	LS/HS Source 6
5	DRAIN5	LS/HS Drain 5
6	SOURCE5	LS/HS Source 5
7	NRES	NRES function – available only in VFQFPN32 package
8	DIS	Channel disable – available only in VFQFPN32 package
9	IN1	Parallel command input 1
10	IN0	Parallel command input 0
11	N.C.	-
12	GND	Ground pin
13	IDLE	Idle function
14	VDDIO	IO supply
15	SO	SPI output stream
16	CLK	SPI clock
17	NCS	SPI Chip Select
18	SI	SPI input stream
19	DRAIN4	LS/HS Drain 4
20	SOURCE4	LS/HS Source 4
21	DRAIN3	LS/HS Drain 3
22	SOURCE3	LS/HS Source 3
23	DRAIN2	LS/HS Drain 2
24	SOURCE2	LS/HS Source 2
25	N.C.	-
26	N.C.	-
27	SOURCE1	HS Source 1
28	DRAIN1	HS Drain 1
29	VBATT	Battery voltage
30	DRAIN0	HS Drain 0
31	SOURCE0	HS Source 0
32	N.C.	-

**Note:**

- In case of VFQFPN32 package, `CFG_0.DIS_EN` and bit `CFG_0.NRES_N` needs to set through SPI.
- In case of HTSSOP24 package, `NRES` and `DIS` pins are not available; `CFG_0.DIS_EN` and bit `CFG_0.NRES_N` must be considered as reserved, kept at '0'.
- For both package options the exposed pad must be left floating to guarantee the reverse battery protection feature.



## 4 Product characteristics

### 4.1 Absolute maximum ratings

This part may be irreparably damaged if taken outside the specified Absolute Maximum Ratings. Operation above the Absolute Maximum Ratings may also cause a decrease in reliability.

The operating junction temperature range is  $-40\text{ }^{\circ}\text{C}$  to  $+150\text{ }^{\circ}\text{C}$ . The maximum junction temperature must not be exceeded. All voltages are referred to analog ground pin GND.

**Table 4. Absolute maximum rating capability**

Symbol	Type	Test condition	Min	Typ	Max	Unit	Pin type
VBATT	Global	$t_{on} = 400\text{ ms}$ ; $t_{on}/t_{off} = 10\%$ ; limited to 100 pulses	-0.3	-	42	V	S
VDDIO	Local	-	-0.3	-	20	V	S
-VBATT <sub>(REV)</sub>	Global	Reverse polarity voltage $T = 25\text{ }^{\circ}\text{C}$ , $t < 2\text{ min}$ , $R_L = 70\ \Omega$ on all channels, with exposed pad floating	-	-	16	V	S
V <sub>OUT_S</sub>	Global	Power transistor source voltage	-16	-	Min[V <sub>OUT_D</sub> + 0.3, 42]	V	O
V <sub>OUT_D</sub>	Global	Power transistor drain voltage (V <sub>OUT_S</sub> $\geq 0\text{ V}$ )	V <sub>OUT_S</sub> - 0.3	-	42	V	O
V <sub>IDLE</sub>	Local	-	-0.3	-	20	V	I
V <sub>IN0</sub>	Local	-	-0.3	-	20	V	I
V <sub>IN1</sub>	Local	-	-0.3	-	Min[VDDIO + 0.3, 20]	V	I
V <sub>NCS</sub>	Local	-	-0.3	-	20	V	I
V <sub>CLK</sub>	Local	-	-0.3	-	20	V	I
V <sub>SI</sub>	Local	-	-0.3	-	20	V	I
V <sub>SO</sub>	Local	-	-0.3	-	Min[VDDIO + 0.3, 20]	V	O
V <sub>IN</sub>	Local	Applies to : V <sub>NRES</sub> V <sub>DIS</sub>	-0.3	-	20	V	I

### 4.2 Latchup trials

Latch-up tests performed according to JEDEC 78 class 2 Level A

### 4.3 Temperature range

**Table 5. Temperature range**

Symbol	Description	Test condition	Min	Typ	Max	Unit
Ta	Operating ambient temperature	-	-40	-	125	°C
Tj	Junction temperature	-	-40	-	150	°C
Tstg	Storage temperature	-	-55	-	150	°C
RTHj-a	Thermal resistance junction to ambient	- Package: HTSSOP - 2s2p (4L) board <sup>(1)</sup> - Natural convection	-	38	-	°C/W
RTHj-c	Thermal resistance junction to case		-	1	-	
RTHj-b	Thermal resistance junction to board		-	20	-	
RTHj-a	Thermal resistance junction to ambient	- Package: VFQFPN - 2s2p (4L) board <sup>(1)</sup> - Natural convection	-	36	-	°C/W
RTHj-c	Thermal resistance junction to case		-	4	-	
RTHj-b	Thermal resistance junction to board		-	18	-	

1. JESD51-7

All parameters are guaranteed, and tested, in the temperature range Tj -40 ÷ 150 °C (unless otherwise specified).

## 5 Input / Output

### 5.1 Parallel inputs (IN0, IN1)

Device has two input pins available. Each input pin is connected by default to one channel (IN0 to channel 2, IN1 to channel 3). Input Mapping Registers MAP\_IN0 and MAP\_IN1 can be programmed to connect different channels to each input pin. The signals driving the channels are an OR combination between PWM\_SPI register status, PWM Generators (according to PWM Generator Output Mapping status), IN0 and IN1 (according to Input Mapping registers status). See [Section 11 SPI](#) for further details.

The logic level of the input pins can be monitored via the status register STA\_0. The Input Status Monitor is operative also when device is in Limp Home mode. If one of the Input pins is set to “high” and the IDLE pin is set to “low”, the device switches into Limp Home mode and activates the channel mapped by default to the input pins.

### 5.2 Idle pin (IDLE)

The IDLE pin is used to bring the device into Sleep mode operation when is set to “low” together with IN0, IN1 input pins being at “low” state. When IDLE pin is set to “low” while one of the input pins is set to “high” the device enters Limp Home mode.

To ensure a proper mode transition, IDLE pin must be set for at least  $t_{IDLEFLT\_max}$  (transition from “high” to “low” or from “low” to “high”).

Setting the IDLE pin to “low”, with both IN0 and IN1 also at “low” value, has the following consequences:

- Device goes in SLEEP MODE
- All registers in the SPI are reset to default values
- VDDIO and VBATT Under voltage detection circuits are disabled to decrease current consumption
- No SPI communication is allowed: SO pin remains in high impedance state also when NCS pin is active.

### 5.3 Reset pin (NRES, only in VFQFPN32 package option)

The NRES pin, available only for VFQFPN32 version, is the reset input for the device. The function uses the inverse logic, if the NRES pin is low, the device is held in an internal reset state, all outputs channels are disabled, and all registers are reset to their default values. An internal pull down will hold the NRES pin asserted in case of pin open. As default, the state of NRES pin is masked by the logic. The user must send a specific SPI frame to force the logic to take into account the state of NRES pin.

### 5.4 Enable (DIS, only in VFQFPN32 package option)

The DIS pin, available only for VFQFPN32 version, is used to enable / disable the output stages. When DIS pin is high, all channels are disabled if the pin is not masked. An internal pull up will hold the DIS pin asserted in case of pin open.

When DIS pin is set low, all channels are enabled based on their configuration settings. As default, the DIS pin is masked by the logic. The user needs to send a specific SPI frame to force the logic to take into account the state of DIS pin. The status of DIS pin can be monitored reading the STA\_0 register.

The DIS pin can be connected to a general purpose output pin of the microcontroller or to an alternative safety circuit.

### 5.5 SPI communications (NCS, CLK, SI & SO)

The NCS, CLK, SI & SO pins provide serial communications between the device and the microcontroller. See [Section 11 SPI](#) for details on SPI features, device register functions and electrical characteristics.

## 5.6 Input / output electrical specifications

$3\text{ V} \leq \text{VDDIO} \leq 5.5\text{ V}$ ;  $6\text{ V} \leq \text{VBATT} \leq 18\text{ V}$ ;  $-40\text{ }^\circ\text{C} \leq \text{Tj} \leq 150\text{ }^\circ\text{C}$  unless otherwise specified. All voltages are referred to GND pin.

**Table 6. Digital input/output electrical performance**

Parameter	Description	Test condition	Min	Typ	Max	Unit	Pin
$V_{\text{IDLE(L)}}$	L-input level	-	-	-	0.8	V	IDLE
$V_{\text{IDLE(H)}}$	H-input level	-	2	-		V	IDLE
$R_{\text{IDLE}}$	Input pull-down resistor at IDLE pin	$\text{VDDIO} = 5\text{ V}$ ; $\text{V}_{\text{DIS}} = 2\text{ V}$	60	-	125	k $\Omega$	IDLE
$V_{\text{IN(L)}}$	L-input level	-	-	-	0.8	V	IN0-IN1
$V_{\text{IN(H)}}$	H-input level	-	2	-		V	IN0-IN1
$R_{\text{IN}}$	Input pull-down resistor at IN0 and IN1 pin	$\text{VDDIO} = 5\text{ V}$ ; $\text{V}_{\text{DIS}} = 2\text{ V}$	60	-	125	k $\Omega$	IN0-IN1
$V_{\text{NRES(L)}}$	L-input level	-	-	-	0.8	V	NRES
$V_{\text{NRES(H)}}$	H-input level	-	2	-		V	NRES
$R_{\text{NRES}}$	Input pull-down resistor at NRES pin	$\text{VDDIO} = 5\text{ V}$ ; $\text{V}_{\text{DIS}} = 2\text{ V}$	70	-	140	k $\Omega$	NRES
$V_{\text{DIS(L)}}$	L-input level	-	-	-	0.8	V	DIS
$V_{\text{DIS(H)}}$	H-input level	-	2	-		V	DIS
$R_{\text{DIS}}$	Input pull-up resistor at DIS pin	$\text{VDDIO} = 5\text{ V}$ ; $\text{V}_{\text{DIS}} = 0.8\text{ V}$	40	-	95	k $\Omega$	DIS

## 6 Power supply

### 6.1 Overview

The L9026 is fed by two supply voltages:

- VBATT (general supply for analog and digital part)
- VDDIO (supply for digital and output buffers)

The supply lines are monitored against under voltage: in case under voltage condition is detected the IC reacts as per the following:

- An under voltage on VBATT supply voltage prevents the activation of the power stages.
- An under voltage on VDDIO supply prevents any SPI communication and SPI read/write registers are reset to default values.

The combination of the different under voltage conditions are reported in [Table 7](#).

**Table 7. Supply ranges**

	VDDIO ≤ VDDIO <sub>(UV)</sub>	VDDIO > VDDIO <sub>(UV)</sub>
VBATT ≤ VBATT <sub>uv</sub>	channels cannot be controlled	channels cannot be controlled
	SPI registers reset	SPI registers available
	SPI communication not available	SPI communication possible
	Limp Home mode not available	Limp Home mode available(channels are OFF)
VBATT > VBATT <sub>uv</sub>	channels cannot be controlled by SPI (INn functionality still available)	channels can be switched ON and OFF
	SPI registers reset	SPI registers available
	SPI communication not available	SPI communication possible

### 6.2 Battery supply (VBATT)

This pin is the general supply for analog and digital part unless an undervoltage condition is detected on VBATT. In this case, provided VDDIO is still in range, the logic is supplied by the VDDIO itself. The [Table 8](#) summarizes the functional ranges dependent on battery supply voltage.

**Table 8. VBATT electrical performance**

Symbol	Parameter	Test condition	Min	Typ	Max	Unit
VBATT	Supply Voltage Range for normal operations	3 V ≤ VDD ≤ 5.5 V	6	-	18	V
VBATT	Upper Supply Voltage Range for extended operations	3 V ≤ VDD ≤ 5.5 V	18	-	28	V
VBATT Low Voltage	Low Voltage Range Cranking <sup>(1)</sup>	3 V ≤ VDD ≤ 5.5 V	3	-	6	V

1. Possible degradation of electrical parameters linked to battery line. Full functional operation will resume without operator intervention when battery voltage returns to Normal Operating Voltage Range.

The device operates on 12 V system. Transient operation for these systems can reach 40 V maximum. Particular care has to be taken in PCB manufacturing to keep thermal dissipation to a reasonable level.

- For VBATT < VBATT<sub>(UV)</sub> the device is in a safety state (internal circuitries are on but all the outputs are off).
- For VBATT up to 40 V all the functions are granted with increased power dissipation and no reset is asserted during transient.

## 6.3 Operating modes

The L9026 has 4 operative modes as per below:

- Sleep mode
- Idle mode
- Active mode
- Limp Home mode

The transition between operation modes is determined according to the following levels and states:

- logic level at IDLE pin
- logic level at INn pins
- PWM\_SPI.OUTn bits state
- CFG\_1.ACT bit state
- MAP\_PWM.OUTn and PWM\_SEL.OUTn bits state

The [Figure 6](#) represents the possible transitions in the state diagram. The description is valid if the digital POR signal is de-asserted (indicated as POR\_N in the register map). In case of POR = 0 transitions from Active to idle and from Limp Home to Sleep do not guarantee switch off behavior with functional timings. A POR condition is traced in a clear on read register in the STA\_1.POR bit. The behavior of the device as well as some parameters may change depending on the operating mode of the device. Furthermore, due to the under voltage detection circuitry which monitors VBATT and VDDIO supply voltages, some changes within the same operation mode can be seen accordingly.

In case of  $VBATT < VBATT(UV\_L)$  and IDLE = IN0 = IN1 = high device doesn't go from IDLE state to ACTIVE state.

Starting from Active state in the condition IDLE = '0' and INn = '0' (that corresponds to the transition Active to Sleep) to guarantee drivers turn OFF it is necessary also a SW reset.

There are different options to observe the operation mode of the device:

- status of output channels
- status of SPI registers
- current consumption at VBATT pin (IVBATT)

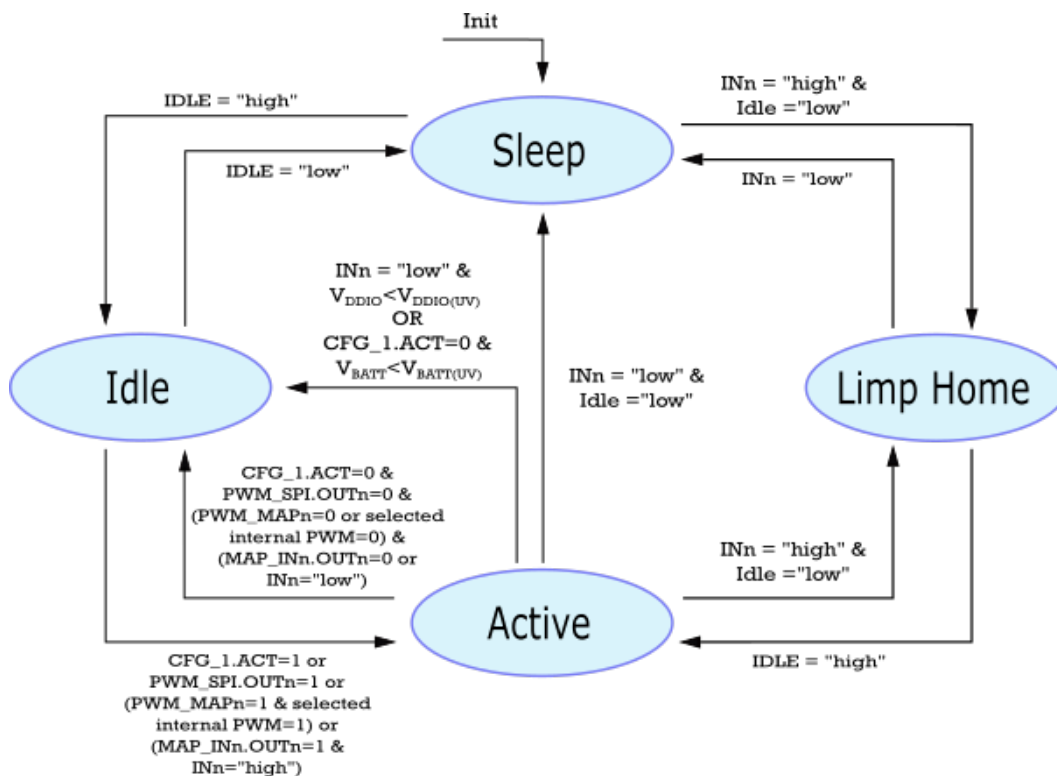
**Figure 6. State diagram**

The default operation mode to switch ON the loads is Active mode. If the device is not in Active mode and a request to switch ON one or more outputs occurs (via SPI or via Input pins), it will switch into Active or Limp Home mode, according to IDLE pin status. Due to the time needed for such transitions, output turn-on time  $t_{ON}$  will be extended due to the mode transition latency.

Table 9 shows the correlation between device operation modes, VBATT and VDDIO supply voltages, and state of device functions (channels operability, SPI communication and SPI registers).

**Table 9. Functions availability in different supply conditions**

Operating mode	Function	Under voltage condition on VBATT		VBATT not in under voltage	
		VDDIO ≤ VDDIO <sub>UV</sub>	VDDIO > VDDIO <sub>UV</sub>	VDDIO ≤ VDDIO <sub>UV</sub>	VDDIO > VDDIO <sub>UV</sub>
Sleep	Channels	not available	not available	not available	not available
	SPI comm.	not available	not available	not available	not available
	SPI registers	reset	reset	reset	reset
Idle	Channels	not available	not available	not available	not available
	SPI comm.	not available	available	not available	available
	SPI registers	reset	available	reset	available
Active	Channels	not available	not available	available (IN pins only)	available
	SPI comm.	not available	available	not available	available
	SPI registers	reset	available	reset	available
Limp Home	Channels	not available	not available	available (IN pins only)	available (IN pins only)
	SPI comm.	not available	available (read-only)	not available	available (read-only)
	SPI registers	reset	available (read-only)	reset	available (read-only)

## 6.4 Analog & Digital supply (VBATT)

The VBATT is used to supply the internal logic, analog and digital, in normal condition (no under voltage on VBATT) and the output loads.

In case the voltage drops below  $VBATT_{(UV\_L)}$  the under voltage mechanism is triggered and the bit  $STA\_1.VS\_UV$  is reported via SPI. Once the faulty condition disappears ( $VBATT > VBATT_{(UV\_H)}$ ), the bit remains latched until its status is acknowledged by the microcontroller via SPI.

Under voltage condition on VBATT influences the status of the channels as described in [Table 7](#).

## 6.5 I/O Supply (VDDIO)

VDDIO is the supply for all pins that interface with the external microcontroller and also works as feed for the internal logic if VBATT is in under voltage condition.

In case the voltage drops below  $VDDIO_{(UV)}$  the under voltage mechanism is triggered and the bit  $STA\_1.VDD\_UV$  is reported via SPI. This is valid if digital  $POR\_N$  is '1'. For all conditions that generate a  $POR\_N=0$ , a dedicated clear on read  $STA\_1.POR\_N$  bit is set. Once the faulty condition disappears, the bit remains latched until its status is acknowledged by the microcontroller via SPI.

## 6.6 Power up

The IC performs Power-up procedure when one of the supply voltages (VBATT or VDDIO) is applied to the device and the INn or IDLE pins are set to "high".

## 6.7 Sleep mode

When device is in Sleep mode, all outputs are OFF and the SPI registers are reset, independently of the supply voltages. The current consumption is reduced to the  $IVDDIO(SLEEP)$  and  $IVBATT(SLEEP)$ .

## 6.8 Idle mode

In Idle mode, the current consumption of the device reaches the parameters  $IVDDIO(IDLE)$  and  $IVBATT(IDLE)$ . The internal voltage regulator is still working. ON diagnosis functions are not available. The output channels are switched OFF, independently of the supply voltages. When VDDIO is available, the SPI registers are working and SPI communication is possible. In Idle mode the  $DIAG\_OVC\_OVT$  bits are not cleared.

## 6.9 Active mode

Active mode is the normal operation mode when no Limp Home condition is set and it is necessary to drive some or all loads. Voltage levels of VDDIO and VBATT influence the behavior as described in detail in [Section 6.1 Overview](#). Device current consumption is specified with  $IVDDIO(ACTIVE)$  and  $IVBATT(ACTIVE)$ .

In case  $CFG\_1.ACT$  is set to "1", the device enters in Active mode and remains in this state independently on the status of input pins, of internal PWM generators and  $PWM\_SPI.OUTn$  bits.

Otherwise, in case the bit  $CFG\_1.ACT$  is not set, in order to move the device in Active mode all conditions below are needed:

- the IDLE pin set to "high"
- the outputs configured as driven either by external pins (through  $MAPIN0$ ,  $MAPIN1$  registers) or by SPI (at least one  $PWM\_SPI.OUTn$  bit is set to "1") or by the internal PWM generators (through  $MAP\_PWM$ )
- at least one channel enabled

In this scenario, the device returns to Idle mode as soon as IDLE pin set to "low", all inputs pins are set to "low", all  $PWM\_SPI.OUTn$  bits are set to "0" and all the internal pwm generators are OFF.

Being the IDLE pin asserted high, an under voltage condition on VDDIO supply brings the device into Idle mode once all INn input pins are set to "low", on top of the setting of the bit  $CFG\_1.ACT$ .



### 6.10 Limp Home mode

Device enters Limp Home mode when IDLE pin is “low” and one of the input pins is set to “high”, switching ON the channel connected to it. SPI communication is possible but in read-only mode (SPI registers can be read but cannot be written).

More in detail, Limp Home mode has the following effects:

- IN0 is mapped as channel 2 input command, IN1 is mapped as channel 3 input command
- MODE bits are set to “01B” (Limp Home mode)
- Overload and Over temperature diagnostics on channel 2 and 3 are available and the related DIAG\_OVC\_OVT bits can be read.

Entering Limp Home mode from sleep means that all other registers are set to their default value and cannot be programmed as long as the device is in Limp Home mode (SPI in read only mode) so far a special feature for Channel 2 and 3 is implemented and channels are able of auto-configuring as LS or HS depending on the configuration of the external load.

Open in ON diagnosis is not performed in Limp Home mode. This is true also if Limp Home mode has been entered from Active mode and DIAG\_OPL\_ON\_EN.OUTn bits are set to '1'. In this case, the diagnostic cycles will be performed only when back in ACTIVE mode.

See Table 9 for a detailed overview of supply voltage conditions required to switch ON channels 2 and 3 during Limp Home. All other channels are kept OFF.

### 6.11 Power supply transition

The channel turn-ON time is defined by parameter  $t_{ON}$  when device is in Active mode or in Limp Home mode. In all other cases, it is necessary to add the transition time required to reach one of the two above mentioned Power Supply modes, as reported in Figure 7.

Figure 7. Transition times block diagram

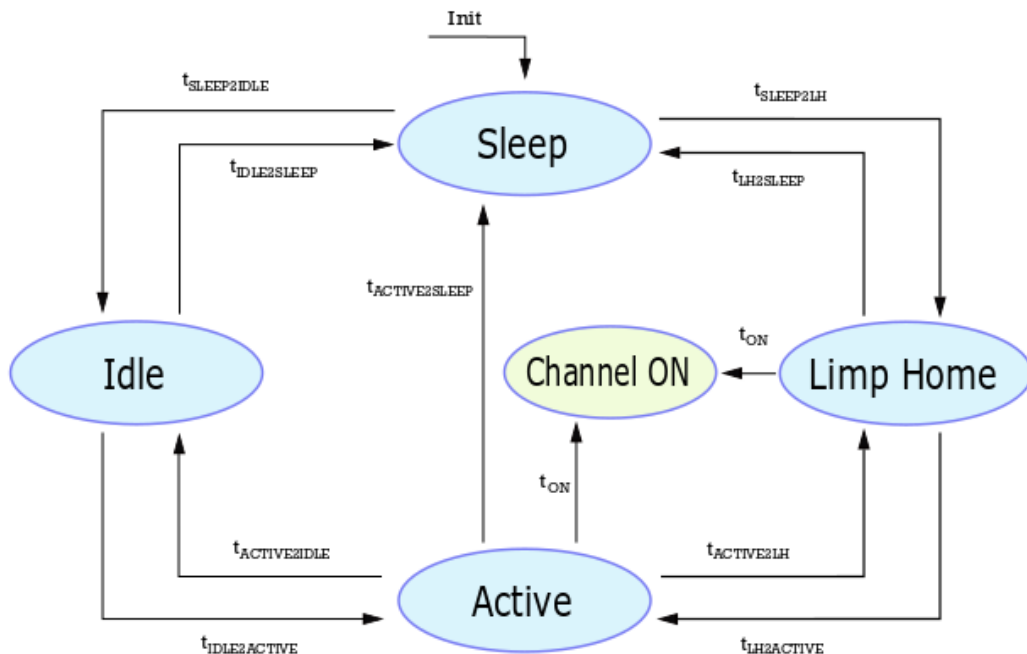

## 6.12 Reset

One of the following 4 conditions reset the SPI read/write registers to the default value:

- VDDIO not present or below the undervoltage threshold VDDIO(UV)
- IDLE pin is set to “low” with both INn “low”
- A software reset (CFG\_1.RST set to “1”) is commanded
- NRES pin is asserted (only available in VFQFPN32 package option and configured to sense the pin status)

When the SPI registers are reset, all channels (except 2,3) are switched OFF and the Input Mapping configuration is also reset. This means channels 2, 3 are still commanded by IN0, IN1 respectively.

For functional safety register DIAG\_OVC\_OVT and STA\_1.VDDIO\_UV, STA\_1.VBATT\_UV bits are not cleared by a reset command.

One of the following conditions resets the whole internal logic;

- General internal supply failure (internal supply 3.3 V in UV or bandgap reference not correct)
- VDDIO < VDDIO(UV) and IN1 = 0 and IN0 = 0

## 6.13 Power supply electrical specifications

3V ≤ VDDIO ≤ 5.5 V; 6 V ≤ VBATT ≤ 18 V; -40 °C ≤ Tj ≤ 150 °C unless otherwise specified. All voltages are referred to GND pin.

**Table 10. Power supply electrical parameters**

Parameter	Description	Test condition	Min	Typ	Max	Unit
<b>VBATT pin</b>						
VBATT(UV_L)	Analog supply undervoltage low threshold	-	2.65	2.8	2.95	V
VBATT(UV_H)	Analog supply undervoltage high threshold	-	2.7	2.85	3	V
I <sub>VBATT(SLEEP)</sub>	Analog supply current consumption in Sleep mode	V <sub>IDLE</sub> = 0; V <sub>INn</sub> = 0; VDDIO = 5 V; T <sub>J</sub> ≤ 85 °C	-	-	12	μA
I <sub>VBATT(SLEEP)</sub>	Analog supply current consumption in Sleep mode	V <sub>IDLE</sub> = 0; V <sub>INn</sub> = 0; VDDIO = 5 V; T <sub>J</sub> ≤ 175 °C	-	-	14	μA
I <sub>VBATT(IDLE)</sub>	Analog supply current consumption in Idle mode	V <sub>IDLE</sub> = 5 V; V <sub>INn</sub> = 0; VDDIO = 5 V; f <sub>SCLK</sub> = 0 MHz; CFG_1.ACT = 0 <sub>B</sub> ; PWM_SPI.OUTn = 0 <sub>B</sub> ; DIAG_OFF_EN.OUTn = 0 <sub>B</sub>	-	-	20	mA
I <sub>VBATT(IDLE_COR)</sub>	Analog supply current consumption in Idle Mode with VBATT lower than VDDIO (device supplied by VDDIO)	V <sub>IDLE</sub> = 5 V; V <sub>INn</sub> = 0; VDDIO = 5 V; f <sub>SCLK</sub> = 0 MHz; CFG_1.ACT = 0 <sub>B</sub> ; PWM_SPI.OUTn = 0 <sub>B</sub> ; DIAG_OFF_EN.OUTn = 0 <sub>B</sub> ; VBATT = VDDIO - 1 V	-0.1	-	0.1	mA
I <sub>VBATT(ACTIVE)</sub>	Analog supply current consumption in Active mode - channels OFF	V <sub>IDLE</sub> = 5 V; V <sub>INn</sub> = 0; VDDIO = 5 V; f <sub>SCLK</sub> = 0 MHz; CFG_1.ACT = 1 <sub>B</sub> ; PWM_SPI.OUTn = 0 <sub>B</sub> ; DIAG_OFF_EN.OUTn = 0 <sub>B</sub>	-	14	20	mA
I <sub>VBATT(ACTIVE_COR)</sub>	Analog supply current consumption in Active mode - channels OFF with VBATT lower than VDDIO (device supplied by VDDIO)	V <sub>IDLE</sub> = 5 V; V <sub>INn</sub> = 0; VDDIO = 5 V; f <sub>SCLK</sub> = 0 MHz; CFG_1.ACT = 1 <sub>B</sub> ; PWM_SPI.OUTn = 0 <sub>B</sub> ; DIAG_OFF_EN.OUTn = 0 <sub>B</sub> ; VBATT = VDDIO - 1 V	-0.1	-	0.1	mA

Parameter	Description	Test condition	Min	Typ	Max	Unit
$t_{VBATTUVFLT}$	VBATT undervoltage filter	Covered bySCAN	9	14	19	$\mu s$
<b>VDDIO pin</b>						
VDDIO(OP)	Logic Supply Operating range voltage	$f_{SCLK} = 8 \text{ MHz}$	3	-	5.5	V
VDDIO(UV_RECOVERY)	Analog supply threshold for recovery after battery undervoltage	MISO from "low" to high impedance	2.7	2.85	3	V
VDDIO(UV)	Undervoltage shutdown	MISO from "low" to high impedance	2.65	2.8	2.95	V
$I_{VDDIO(SLEEP)}$	Logic supply current in Sleepmode	$V_{IDLE} = 0; V_{INn} = 0; VDDIO = 5 \text{ V}; T_J \leq 85 \text{ }^\circ\text{C}$	-	-	1	$\mu\text{A}$
$I_{VDDIO(SLEEP)}$	Logic supply current in Sleep mode	$V_{IDLE} = 0\text{V}; V_{INn} = 0 \text{ V}; VDDIO = 5 \text{ V}; T_J \leq 150 \text{ }^\circ\text{C}$	-	-	2	$\mu\text{A}$
$I_{VDDIO(IDLE)}$	Logic supply current in Idle Mode	$V_{IDLE} = 5 \text{ V}; V_{INn} = 0 \text{ V}; VDDIO = 5 \text{ V}; f_{SCLK} = 0 \text{ MHz}; \text{CFG\_1.ACT} = 0\text{B}; \text{PWM\_SPI.OUTn} = 0\text{B}; \text{DIAG\_OFF\_EN.OUTn} = 0\text{B}$	-	-	1.2	mA
$I_{VDDIO(IDLE)}$	Logic supply current in Idle mode (COR)	$V_{IDLE} = 5 \text{ V}; V_{INn} = 0 \text{ V}; VDDIO = 5 \text{ V}; f_{SCLK} = 0 \text{ MHz}; \text{CFG\_1.ACT} = 0\text{B}; \text{PWM\_SPI.OUTn} = 0\text{B}; \text{DIAG\_OFF\_EN.OUTn} = 0\text{B}; \text{VBATT} = \text{VDDIO} - 1 \text{ V}$	2	-	5	mA
$I_{VDDIO(ACTIVE)}$	Logic supply current in Active mode – channels OFF	$V_{IDLE} = 5 \text{ V}; V_{INn} = 0 \text{ V}; VDDIO = 5 \text{ V}; f_{SCLK} = 0 \text{ MHz}; \text{CFG\_1.ACT} = 1\text{B}; \text{PWM\_SPI.OUTn} = 0\text{B}; \text{DIAG\_OFF\_EN.OUTn} = 0\text{B}$	-	0.95	1.5	mA
$I_{VDDIO(ACTIVE\_COR)}$	Logic supply current in Active mode – channels OFF (COR)	$V_{IDLE} = 5 \text{ V}; V_{INn} = 0 \text{ V}; VDDIO = 5 \text{ V}; f_{SCLK} = 0 \text{ MHz}; \text{CFG\_1.ACT} = 1\text{B}; \text{PWM\_SPI.OUTn} = 0\text{B}; \text{DIAG\_OFF\_EN.OUTn} = 0\text{B}; \text{VBATT} = \text{VDDIO} - 1 \text{ V}$	12	-	20	mA
$t_{VDDIOUVFLT}$	VDDIO undervoltage filter	Covered bySCAN	9	14	19	$\mu s$
<b>Timings</b>						
$t_{IDLEFLT}$	Idle filter time	-	5	7	10	$\mu s$
$t_{SLEEP2IDLE}$	Sleep to Idle delay	-	-	-	10	$\mu s$
$t_{IDLE2SLEEP}$	Idle to Sleep delay	from IDLE pin to sleep External pull-down MISO to GND required	-	-	10	$\mu s$
$t_{IDLE2ACTIVE}$	Idle to Active delay	from INn or NCS pins to MODE = 11 <sub>B</sub>	-	-	1	$\mu s$
$t_{ACTIVE2IDLE}$	Active to Idle delay	from INn or NCS pins to MODE = 10 <sub>B</sub>	-	-	150	$\mu s$
$t_{SLEEP2LH}$	Sleep to Limp Home delay	from INn pins to VDS = 10 % VBATT	-	-	10+t <sub>ON</sub>	$\mu s$
$t_{LH2SLEEP}$	Limp Home to Sleep delay	from INn pins to MODE = 00 <sub>B</sub> External pull-down MISO to GND required.	-	-	150	$\mu s$
$t_{LH2ACTIVE}$	Limp Home to Active delay	from IDLE pin to MODE = 11 <sub>B</sub>	-	-	10	$\mu s$
$t_{ACTIVE2LH}$	Active to Limp Home delay	from IDLE pin to MODE = 01 <sub>B</sub>	-	-	10	$\mu s$
$t_{ACTIVE2SLEEP}$	Active to Sleep delay	from IDLE pin to MODE = 00 <sub>B</sub> External pull-down MISO to GND required.	-	-	150	$\mu s$

## 7 Power stages

There are two fixed high-side channels and six channels which can be used either as low-side or as high-side switches. During the diagnosis in OFF State, the sequences of operations (pull-up or pull-down current source activation) are determined according to the SPI settings of CFG\_0 register.

For the configurable channels, when in high-side configuration, the load is connected between ground and source of the power transistor (pins SOURCE<sub>n</sub>, n = 2...7) while the drains (pins DRAIN<sub>n</sub>, n = 2...7) can be connected to any potential between ground and VBATT.

In low-side configuration, the source of the power transistors must be connected to GND pin potential (either directly or through a reverse current blocking diode).

The configuration can be chosen for each of these configurable channels individually via SPI.

**Figure 8. HS driver (left) and LS driver (right) configuration**

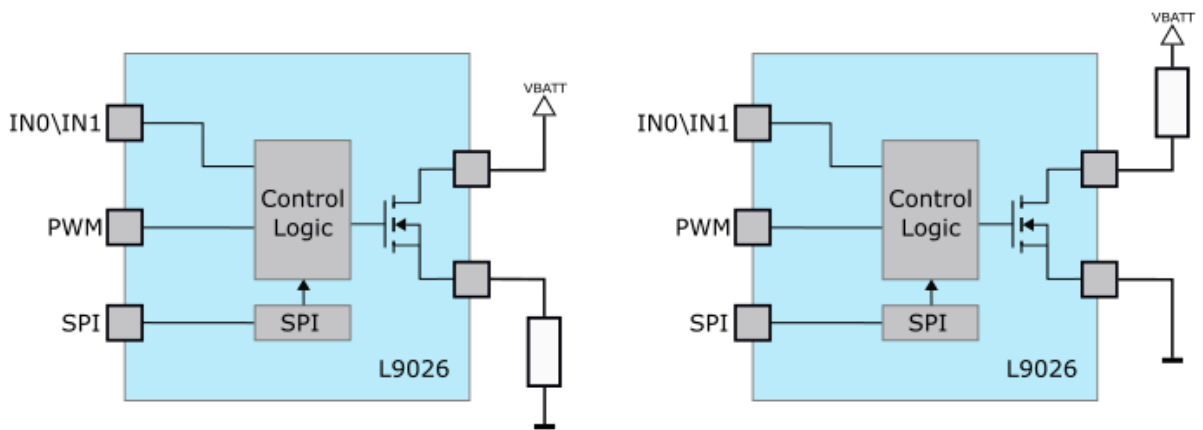

### 7.1 Operating modes

The ON-state resistance  $R_{DS(ON)}$  depends on the supply voltage as well as the junction temperature  $T_J$ .

#### 7.1.1 Switching resistive modes

When switching resistive loads, the following switching times and slew rates can be considered.

Figure 9. Switching resistive loads

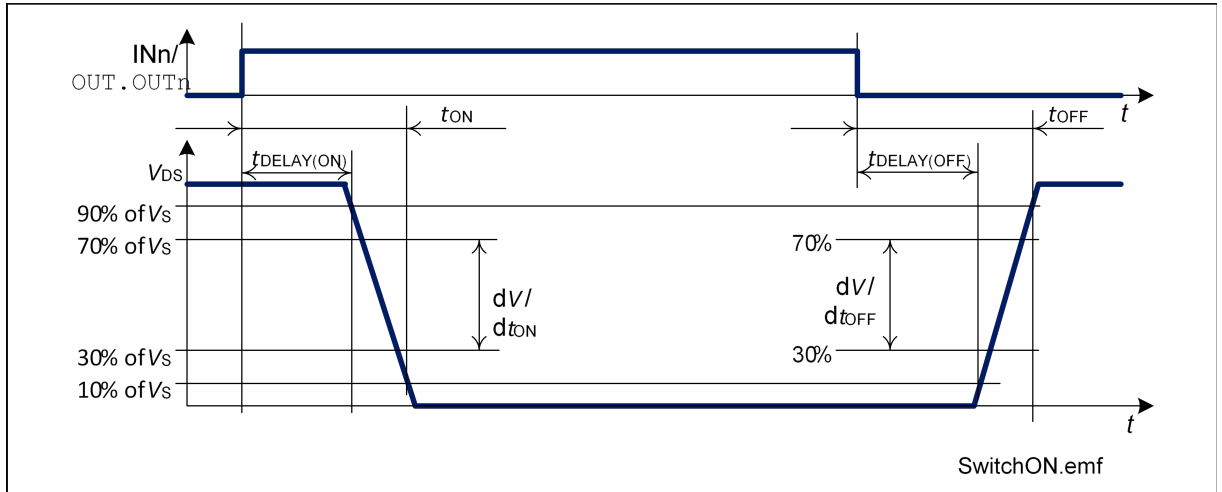

### 7.1.2 Inductive output clamp

When switching off inductive loads, the voltage across the power switch rises to  $V_{DS(CL)}$  potential, because the inductance intends to continue driving the current. In case of HS configuration, the potential at Output pin is not allowed to go below  $V_{OUT\_S(CL)}$ . The voltage clamping is necessary to prevent device destruction.

To clarify this idea Figure 10 shows a concept drawing of the implementation.

Nevertheless, the maximum allowed load inductance is limited by the max energy. The clamping structure protects the device in all operative modes (Sleep, Idle, Active, Limp Home).

Figure 10. Output clamp concept

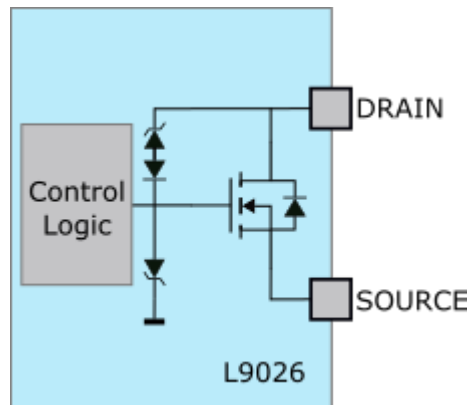

### 7.1.3 Maximum load inductance

During demagnetization of inductive loads, energy has to be dissipated device. Eq. (1) shows how to calculate the energy for low-side switches, while Eq. (2) can be used for high-side switches (auto-configurable switches can use all equations, depending on the load position):

$$E = V_{DS(CL)} \cdot \left[ \frac{V_S - V_{DS(CL)}}{R_L} \cdot I_n \cdot \left( 1 - \frac{R_L \cdot I_L}{V_S - V_{DS(CL)}} \right) + I_L \right] \cdot \frac{L}{R_L} \quad (1)$$

$$E = (V_S - V_{DS(CL)}) \cdot \left[ \frac{V_{OUTS(CL)}}{R_L} \cdot I_n \cdot \left( 1 - \frac{R_L \cdot I_L}{V_{OUTS(CL)}} \right) + I_L \right] \cdot \frac{L}{R_L} \quad (2)$$

The maximum energy, which is converted into heat, is limited by the thermal design of the component. The  $E_{AR}$  value provided in Table 14 assumes that all channels can dissipate the same energy when the inductances connected to the outputs are demagnetized at the same time.

## 7.2 Inverse current behavior

Inverse current ( $V_{OUTn\_S} > V_{OUTn\_D}$ ) in high-side configuration may occur with channels in ON or in OFF state. A reverse current applied to a specific channel has no impact on the general functionality (switch ON and OFF, protection, diagnostic) of unaffected channels.

Parameter deviations are possible for the switching capability of the affected channel, while protection against Over Load and off state diagnostic are not available. Reliability in Limp Home condition for the unaffected channels remains unchanged.

## 7.3 Bulb inrush mode

Although device is optimized for relays and LED, it may be necessary to use one or more of the outputs as high-side switches to drive small lamps or electronic loads with a big input capacitor. In such a case the inrush current at startup may trigger the overload diagnostic, switching the channel OFF.

In normal operation in order to re-engage the channels from an overload condition, an SPI command to clear the latches (register DIAG\_OVC\_OVT) is needed, to allow the channel turning ON again; for some applications this re-engagement procedure takes too long to transfer enough energy to activate the load.

The IC provides means to overcome this issue by setting BIM.OUTn bit to "1".

Once this feature is enabled, in case the channel reaches the overload current threshold and latches OFF, it restarts automatically after a time  $t_{INRUSH}$ , allowing the load to go out of the inrush phase. The automatic re-engagement of the faulty channels lasts for a BIM time ( $t_{BIM}$ ). Once the  $t_{BIM}$  counter is started, it is reset only once the  $t_{BIM}$  is expired, unless a reset condition occurs (VDDIO\_uv, hardware or software reset).

A time diagram is shown in Figure 11. The channel configured with BIM option can be either driven by an SPI command, PWM command (internal generator) or INn parallel input. Once programmed to "1" via SPI, the BIM.OUTn bit is set back to "0" at the end of BIM time ( $t_{BIM}$ ), unless a reset condition occurs (VDDIO\_uv, hardware or software reset): an eventual switch off of the channel commanded by the user has no impact on BIM.OUTn configuration.

Figure 11. Bulb inrush mode

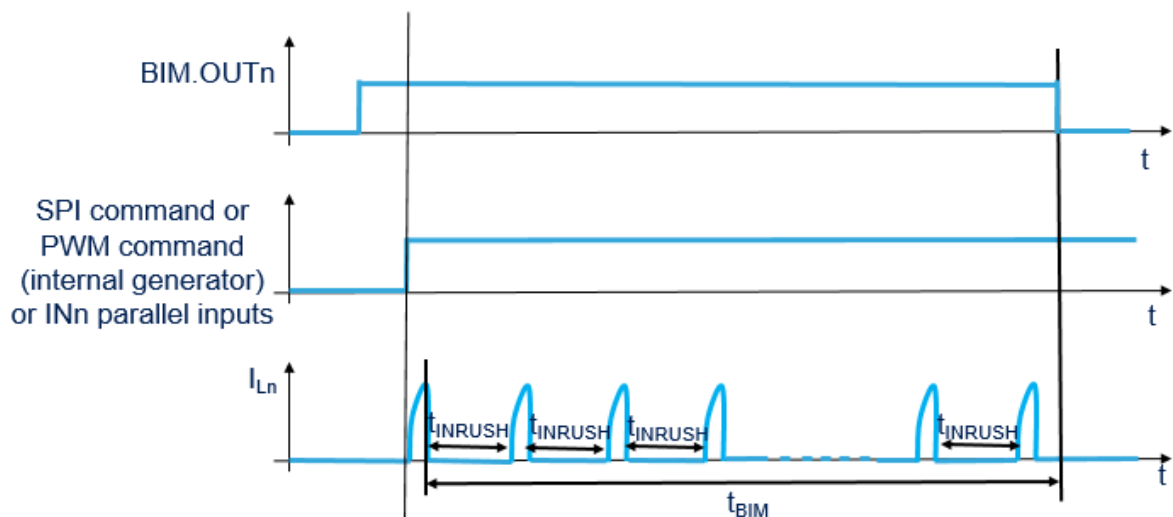

When BIM.OUTn are set to "1", eventual overcurrent/overtemperature conditions will flag DIAG\_OVC\_OVT.OUTn bit, but the affected channels will not be permanently switched OFF. Once asserted, eventual SPI attempt to clear DIAG\_OVC\_OVT.OUTn will be ignored, until the BIM counter is expired. In order to resume the normal behavior when the BIM counter is expired, the DIAG\_OVC\_OVT.OUTn shall be cleared in order to allow IC to perform open load ON diagnosis.

An internal timer set the bit BIM.OUTn back to "0" after 40 ms (parameter  $t_{BIM}$ ) starting from the first overcurrent event latched to prevent an excessive thermal stress to the channel, especially in case of short circuit at the output.

## 7.4 PWM generators

Device has two independent PWM generators, which are defined as “PWM GEN” and “PWM LED” here below. These can be assigned to one or more channels, and can be programmed with different duty cycles and frequencies. Both refer to the same base frequency  $f_{INT}$  (8 MHz typ) even if two separate pre-scalers can be defined.

### 7.4.1 PWM GEN

The first PWM generator is called PWM GEN. Its frequency pre-scaler can be adjusted using CFG\_1.PWM\_DIV\_GEN bits to program target frequency and using CFG\_2.FR\_ADJ bits to modulate fine adjustments around the target. Configuration of fine adjustment is described in Table 11 while target frequency setting is reported in Table 12.

**Table 11. Adjustment coefficients**

CFG_2.FR_ADJ	Absolute delta to $f_{INT}$ divider
00 <sub>B</sub>	0 %
01 <sub>B</sub>	-15 %
10 <sub>B</sub>	+15 %
11 <sub>B</sub>	0 %

The user can set the following parameters to configure the PWM generator:

- duty cycle (bits PWM\_GEN\_DC.DUTY\_CYCLE)
  - 8 configuration bits are available, with 100/255 duty cycle resolution for each LSB
  - The maximum duty cycle achievable is 100% (PWM\_GEN\_DC.DUTY\_CYCLE set to “11111111B”)
  - In case the duty cycle is changed, the next target is applied once the previous PWM period is over and the new one is started. Once a new target is programmed, the behavior above is valid also if the current duty is 100% while when the current duty is 0% the new target value is applied immediately.
- frequency (bits CFG\_1.PWM\_DIV\_GEN)
  - 2 configuration bits are available to select the frequency among 4 target values

**Table 12. PWM GEN generator available frequencies**

CFG_1.PWM_DIV_GEN	PWM frequency
00 <sub>B</sub>	122.5 Hz
01 <sub>B</sub>	245.1 Hz
10 <sub>B</sub>	490.2 Hz
11 <sub>B</sub>	980.4 Hz

- Channels driven by PWM GEN (PWM\_SEL and PWM\_MAP registers)

The correct sequence to use the PWM generator is:

- define the frequency divider through CFG\_1.PWM\_DIV\_GEN bit.
- define duty cycle control register through PWM\_GEN\_DC register.
- set up channel output control through PWM\_SEL register (PWM GEN corresponds to 0)
- define channels driven by PWM selected in PWM\_SEL through mapping register PWM\_MAP

In order to clarify how to select the source that can drive the channels command, the driving tree with all possible sources (ie PWM generators, SPI and parallel inputs) is reported in Figure 12.

Figure 12. Driving tree

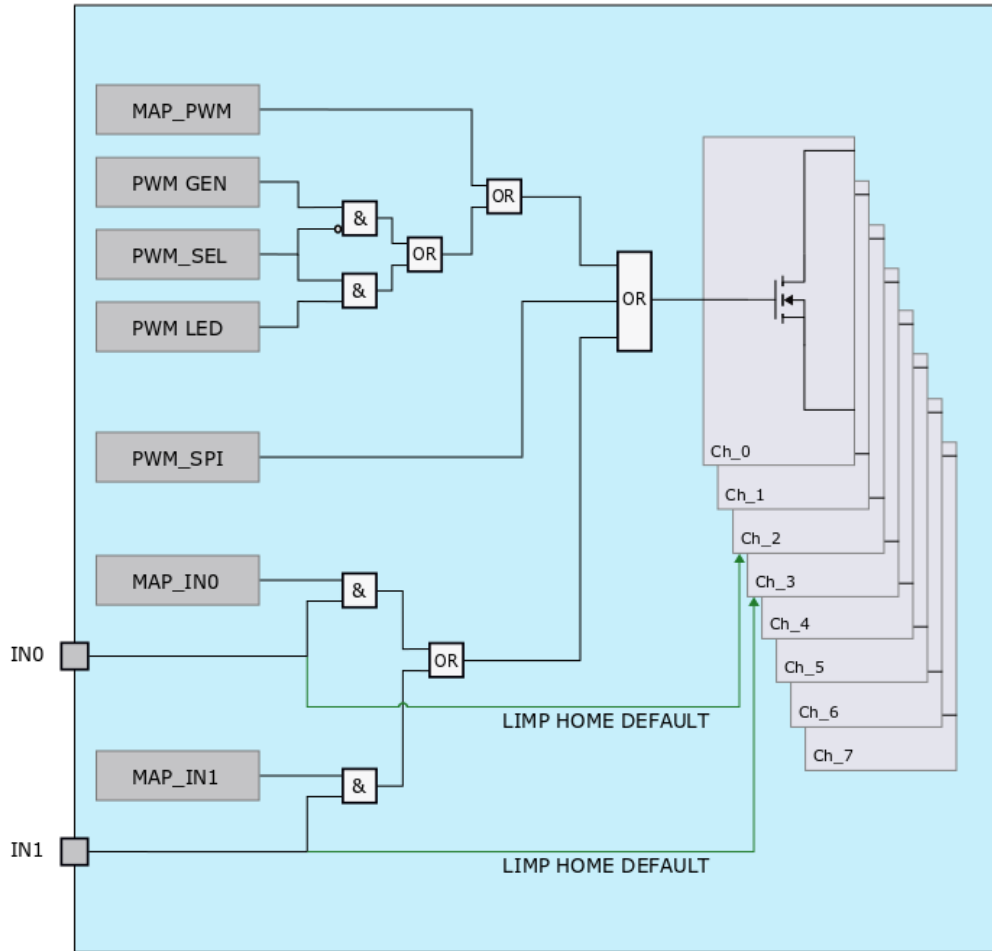

### 7.4.2 PWM LED

The second PWM generator is named PWM LED. Its frequency prescaler can be adjusted using CFG\_2.PWM\_DIV\_LED bits (see Table 13) while the modulation around the defined target is actually shared with PWM GEN, using CFG\_2.FR\_ADJ bits described in Table 11.



The user can set the following parameters to configure the PWM generator:

- duty cycle (bits PWM\_LED\_DC.DUTY\_CYCLE)
  - 8 configuration bits are available, with 100/255 duty cycle resolution for each LSB
  - The maximum duty cycle achievable is 100% (PWM\_LED\_DC.DUTY\_CYCLE set to “11111111B”)
  - In case the duty cycle is changed, the next target is applied once the previous PWM period is over and the new one is started. Once a new target is programmed, the behavior above is valid also if the current duty is 100% while when the current duty is 0% the new target value is applied immediately.
- frequency (bits CFG\_1.PWM\_DIV\_LED)
  - 2 configuration bits are available to select the frequency among 4 target values

**Table 13. PWM LED generator available frequencies**

CFG_2.PWM_DIV_LED	PWM frequency
00 <sub>B</sub>	122.5 Hz
01 <sub>B</sub>	245.1 Hz
10 <sub>B</sub>	490.2 Hz
11 <sub>B</sub>	980.4 Hz

- Channels driven by PWM LED (PWM\_SEL and PWM\_MAP registers)

The correct sequence to use the PWM LED generator is:

- define the frequency divider through CFG\_1.PWM\_LED\_GEN bit.
- define duty cycle control register through PWM\_LED\_DC register.
- set up channel output control through PWM\_SEL register (PWM LED corresponds to 0)
- define channels driven by PWM selected in PWM\_SEL through mapping register PWM\_MAP

## 7.5 Power stages electrical specifications

3 V ≤ VDDIO ≤ 5.5 V; 6 ≤ VBATT ≤ 18 V; -40 °C ≤ T<sub>J</sub> ≤ 150 °C unless otherwise noted. All voltages are referred to GND pin.

**Table 14. Power stages electrical parameters**

Parameter	Description	Test condition	Min	Typ	Max	Unit
R <sub>DS(ON)</sub>	On-State Resistance	T <sub>J</sub> = 25 °C	-	0.75	-	Ω
R <sub>DS(ON)</sub>	On-State Resistance	T <sub>J</sub> = 150 °C; I <sub>L</sub> = 100 mA	-	-	1.5	Ω
I <sub>L(NOM)</sub>	Nominal load current (all channels active)	T <sub>J</sub> ≤ 150 °C; Design info	-	260	500	mA
E <sub>AS</sub>	Maximum energy dissipation single pulse	T = 25 °C, I <sub>L</sub> = 2XIL(EAR)	-	-	50	mJ
E <sub>AS</sub>	Maximum energy dissipation single pulse	T = 150 °C, I <sub>L</sub> = 400 mA	-	-	25	mJ
I <sub>L(EAR)</sub>	Load current for maximum energy dissipation – repetitive (all channels active)	T <sub>J</sub> ≤ 150 °C; Design info	-	220	-	mA
E <sub>AR</sub>	Maximum energy dissipation repetitive pulses - 2*I <sub>L(EAR)</sub> (two channels in parallel)	T <sub>J(0)</sub> = 85 °C; I <sub>L(0)</sub> = 2*I <sub>L(EAR)</sub> ; 2*10 <sup>6</sup> cycles	-	-	15	mJ
E <sub>AR</sub>	Maximum energy dissipation repetitive pulses - I <sub>L(EAR)</sub>	T = 85 °C, 2*10exp6 cycles	-	-	10	mJ
V <sub>DS</sub>	Voltage at power transistor	-	-0.3	-	V <sub>D(CL)</sub>	V
V <sub>D(CL)</sub>	Drain to GND Output clamping voltage LS	I <sub>L</sub> = 10 mA; Low-Side Configuration	45	47	49	V

Parameter	Description	Test condition	Min	Typ	Max	Unit
$V_{S(CL)}$	Source to GND Output clamping voltage HS	$I_L = 10 \text{ mA}$ ; $V_{BATT} = V_{OUT\_Dn} = 7 \text{ V}$ ; High-Side Configuration	-18	-17	-16	V
$I_{L(OFF)}$	Output leakage current (each channel) $T_J = 150 \text{ }^\circ\text{C}$	$V_{BATT} = 0 \text{ V}$ ; $V_{DDIO} = 0 \text{ V}$ ; $V_{SOURCE} = 0 \text{ V}$ ; $V_{DS} = 28 \text{ V}$ ; $T_J$ up to $150 \text{ }^\circ\text{C}$	-3	0	3	$\mu\text{A}$
$I_{L(OFF)\_HS}$	Output leakage current (each channel) $T_J = 150 \text{ }^\circ\text{C}$	$V_{BATT} = 28 \text{ V}$ ; $V_{DDIO} = 0 \text{ V}$ ; $V_{SOURCE} = 0 \text{ V}$ ; $V_{DS} = 28 \text{ V}$ ; $T_J$ up to $150 \text{ }^\circ\text{C}$ – High side case	-3	-	3	$\mu\text{A}$
$I_{(OFF)\_HS}$	Output current (each channel) in High side case	High side configuration, Power OFF, $V_{SOURCE} = 0 \text{ V}$	-70	-	-30	$\mu\text{A}$
$I_{(OFF)\_HS}$	Output current (each channel) in High side case	High side configuration, Power OFF, $V_{SOURCE} = 2.5\text{V}$	-10	-	10	$\mu\text{A}$
Timing						
$t_{DELAY(ON)}$	Turn-ON delay (from INn pin or bit to $V_{OUT} = 90\% V_{BATT}$ ) (Channels used as Low-Side)	$R_L = 50 \text{ } \Omega$ $V_{BATT} = 14 \text{ V}$ Active or Limp Home mode	3	5	7	$\mu\text{s}$
$t_{DELAY(OFF)}$	Turn-OFF delay (from INn pin or bit to $V_{OUT} = 10\% V_{BATT}$ ) (Channels used as Low-Side)	$R_L = 50 \text{ } \Omega$ ; $V_{BATT} = 14 \text{ V}$ ; Active or Limp Home mode	2.5	10	21	$\mu\text{s}$
$t_{ON}$	Turn-ON time (from INn pin or bit to $V_{OUT} = 10\% V_{BATT}$ ) (Channels used as Low-Side)	$R_L = 50 \text{ } \Omega$ ; $V_{BATT} = 14 \text{ V}$ ; Active or Limp Home mode	7	15	35	$\mu\text{s}$
$t_{OFF}$	Turn-OFF time (from INn pin or bit to $V_{OUT} = 90\% V_{BATT}$ ) (Channels used as Low-Side)	$R_L = 50 \text{ } \Omega$ ; $V_{BATT} = 14 \text{ V}$ ; Active or Limp Home mode	4	-	40	$\mu\text{s}$
$dV/dt_{ON}$	Turn-ON slew rate $V_{DS} = 70\%$ to $30\% V_{BATT}$ (Channels used as Low-Side)	$R_L = 50 \text{ } \Omega$ ; $V_{BATT} = 14 \text{ V}$ ; Active or Limp Home mode	0.35	1	2.2	$\text{V}/\mu\text{s}$
$-dV/dt_{OFF}$	Turn-OFF slew rate $V_{DS} = 30\%$ to $70\% V_{BATT}$ (Channels used as Low-Side)	$R_L = 50 \text{ } \Omega$ ; $V_{BATT} = 14 \text{ V}$ ; Active or Limp Home mode	0.15	1.3	3.4	$\text{V}/\mu\text{s}$
$-dV/dt_{OFF}$	Turn-OFF slew rate $V_{DS} = 30\%$ to $70\% V_{BATT}$ Gate kill condition (Channels used as Low-Side)	$R_L = 50 \text{ } \Omega$ ; $V_{BATT} = 14 \text{ V}$ ; Active or Limp Home mode	12	-	35	$\text{V}/\mu\text{s}$
$t_{DELAY(ON)}$	Turn-ON delay (from INn pin or bit to $V_{OUT} = 10\% V_{BATT}$ ) (Channels used as High-Side)	$R_L = 50 \text{ } \Omega$ ; $V_{BATT} = 14 \text{ V}$ ; Active or Limp Home mode	1.2	3.5	7.5	$\mu\text{s}$
$t_{DELAY(OFF)}$	Turn-OFF delay (from INn pin or bit to $V_{OUT} = 90\% V_{BATT}$ ) (Channels used as High-Side)	$R_L = 50 \text{ } \Omega$ ; $V_{BATT} = 14 \text{ V}$ ; Active or Limp Home mode	2	10	21	$\mu\text{s}$
$t_{ON}$	Turn-ON time (from INn pin or bit to $V_{OUT} = 90\% V_{BATT}$ ) (Channels used as High-Side)	$R_L = 50 \text{ } \Omega$ ; $V_{BATT} = 14 \text{ V}$ ; Active or Limp Home mode	7	16	25	$\mu\text{s}$
$t_{OFF}$	Turn-OFF time (from INn pin or bit to $V_{OUT} = 10\% V_{BATT}$ ) (Channels used as High-Side)	$R_L = 50 \text{ } \Omega$ ; $V_{BATT} = 14 \text{ V}$ ; Active or Limp Home mode	5	19	35	$\mu\text{s}$
$dV/dt_{ON}$	Turn-ON slew rate $V_{DS} = 30\%$ to $70\% V_{BATT}$ (Channels used as High-Side)	$R_L = 50 \text{ } \Omega$ ; $V_{BATT} = 14 \text{ V}$ ; Active or Limp Home mode	0.25	1	1.9	$\text{V}/\mu\text{s}$
$-dV/dt_{OFF}$	Turn-OFF slew rate $V_{DS} = 70\%$ to $30\% V_{BATT}$ (Channels used as High-Side)	$R_L = 50 \text{ } \Omega$ ; $V_{BATT} = 14 \text{ V}$ ; Active or Limp Home mode	0.25	-	2.5	$\text{V}/\mu\text{s}$
$-dV/dt_{OFF}$	Turn-OFF slew rate $V_{DS} = 70\%$ to $30\% V_{BATT}$ Gate kill condition (Channels used as High-Side)	$R_L = 50 \text{ } \Omega$ ; $V_{BATT} = 14 \text{ V}$ ; Active or Limp Home mode	6	-	30	$\text{V}/\mu\text{s}$
$t_{INRUSH}$	Bulb Inrush Mode restart time	Active mode; Covered by SCAN	29	40	51	$\mu\text{s}$

Parameter	Description	Test condition	Min	Typ	Max	Unit
$t_{BIM}$	Bulb Inrush Mode reset time	Active mode; Covered by SCAN	29	41	52	ms

**Table 15. PWM electrical parameters**

Parameter	Description	Test condition	Min	Typ	Max	Unit
$f_{INT}$	Internal reference frequency	Covered by SCAN	-	8	-	MHz
$f_{INT(VAR)}$	Internal reference frequency variation		-15	-	15	%
$t_{SYNC}$	Internal reference frequency synchronization time	Covered by SCAN	-	-	10.5	ms

## 8 Protection functions

### 8.1 Overload protection

Device is protected in case of over load or short circuit of the load. This protection is present for each HS and LS driver. There are two over load current thresholds (see Figure 13):

- $I_{L(OVL0)}$  between channel switch ON and  $t_{OVLINDS1}$
- $I_{L(OVL1)}$  after  $t_{OVLIN}$

Figure 13. Overload thresholds

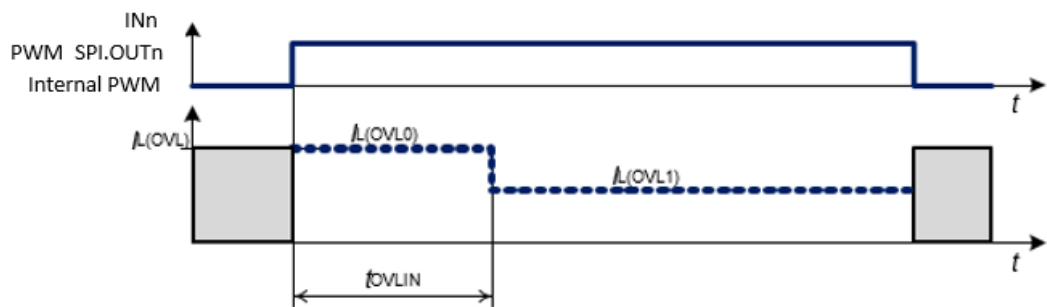

Every time the channel is switched OFF the over load current threshold is set back to  $I_{L(OVL0)}$ .

In case the load current is higher than  $I_{L(OVL0)}$  or  $I_{L(OVL1)}$ , after time  $t_{OFF(OVL)}$  the over loaded channel is switched OFF and the corresponding diagnosis bit `DIAG_OVC_OVT.OUTn` is set to "1". The channel can be switched ON after clearing the protection latch by setting the corresponding `DIAG_OVC_OVT_RLW.OUTn` bit to "1". This bit is set back to "0" internally after de-latching the channel. Please refer to Figure 14 for details.

Figure 14. Latch off in overload condition

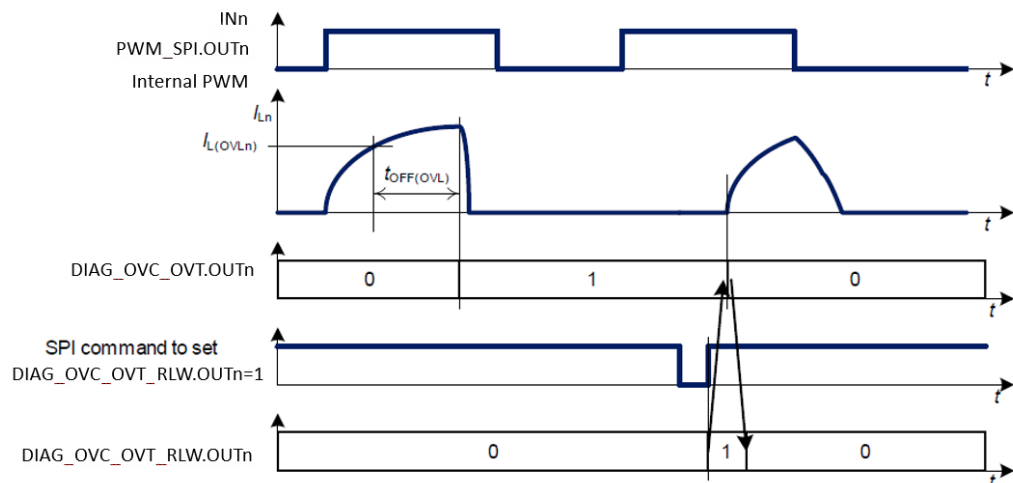

## 8.2 Over temperature protection

A temperature sensor is integrated for each channel. Totally 8 temperature sensors are present, which switch OFF the channel in over temperature in order to prevent destruction.

Once a channel over temperature is detected, the corresponding diagnosis bit DIAG\_OVC\_OVT is set (combined with Over Load protection). The channel can be switched ON after clearing the protection latch by setting the corresponding DIAG\_OVC\_OVT\_RLW.OUTn bit to "1". This bit is set back to "0" internally after de-latching the channel.

## 8.3 Over temperature and over load in Limp Home mode

In Limp Home mode, channels 2 and 3 can be switched ON using the input pins. In case of Over Load, Short Circuit or Over Temperature the channels are switched OFF. If the input pins remain "high", meaning that the channel is still required to be on, in case of Over Load the channels restart at every  $t_{RETRY}$ .

## 8.4 Reverse polarity protection

In Reverse Polarity (also known as Reverse Battery) condition, power dissipation is caused by the intrinsic body diode of each DMOS. The reverse current through the channels has to be limited by the connected loads.

In order to sustain the Reverse polarity condition the exposed pad of device must be left electrically floating.

## 8.5 Electrical characteristics

$3\text{ V} \leq \text{VDDIO} \leq 5.5\text{ V}$ ;  $6\text{ V} \leq \text{VBATT} \leq 18\text{ V}$ ;  $-40\text{ }^\circ\text{C} \leq T_J \leq 150\text{ }^\circ\text{C}$  unless otherwise noticed. All voltages are referred to GND pin.

**Table 16. Over temperature and over load electrical parameters**

Symbol	Description	Test condition	Min	Typ	Max	Unit
$I_{L(OVL0\_LS)}$	Over Load detection current (Channels used as Low-Side)	$T_J = -40\text{ }^\circ\text{C}$	1	-	1.9	A
$I_{L(OVL0\_LS)}$	Over Load detection current (Channels used as Low-Side)	$T_J = 25\text{ }^\circ\text{C}$	1	-	1.7	A
$I_{L(OVL0\_LS)}$	Over Load detection current (Channels used as Low-Side)	$T_J = 150\text{ }^\circ\text{C}$	1	-	1.7	A
$I_{L(OVL1\_LS)}$	Over Load detection current (Channels used as Low-Side)	$T_J = -40\text{ }^\circ\text{C}$	0.6	-	1	A
$I_{L(OVL1\_LS)}$	Over Load detection current (Channels used as Low-Side)	$T_J = 25\text{ }^\circ\text{C}$	0.6	-	1	A
$I_{L(OVL1\_LS)}$	Over Load detection current (Channels used as Low-Side)	$T_J = 150\text{ }^\circ\text{C}$	0.6	-	1	A
$I_{L(OVL0\_HS)}$	Over Load detection current (Channels used as High-Side)	$T_J = -40\text{ }^\circ\text{C}$	1.2	-	2.1	A
$I_{L(OVL0\_HS)}$	Over Load detection current (Channels used as High-Side)	$T_J = 25\text{ }^\circ\text{C}$	1.2	-	1.9	A
$I_{L(OVL0\_HS)}$	Over Load detection current (Channels used as High-Side)	$T_J = 150\text{ }^\circ\text{C}$	1	-	1.7	A
$I_{L(OVL1\_HS)}$	Over Load detection current (Channels used as High-Side)	$T_J = -40\text{ }^\circ\text{C}$	0.7	-	1.4	A
$I_{L(OVL1\_HS)}$	Over Load detection current (Channels used as High-Side)	$T_J = 25\text{ }^\circ\text{C}$	0.7	-	1.3	A

Symbol	Description	Test condition	Min	Typ	Max	Unit
	(Channels used as High-Side)					
$I_{L(OVL1\_HS)}$	Over Load detection current (Channels used as High-Side)	$T_J = 150\text{ }^{\circ}\text{C}$	0.7	-	1.2	A
$t_{OVLIN}$	Over Load threshold switch delay time	Covered by SCAN	110	170	260	$\mu\text{s}$
$t_{OFF(OVL)}$	Over Load shut-down delay time	$BIM.OUTn = 0_B$	4	7	11	$\mu\text{s}$
$T_{J(SC)}$	Thermal shut-down temperature	-	182	192	202	$^{\circ}\text{C}$
$t_{RETRY}$	Restart time in Limp Home mode	Covered by SCAN	29	41	52	ms
$t_{OVC}$	Restart time in Limp Home mode	Covered by SCAN	-	-	50	$\mu\text{s}$

## 9 Diagnosis

The SPI interface provides diagnosis information about the device and the load status. Each channel diagnosis information is independent of other channels. A faulty condition on one channel has no influence on the diagnostic of other channels in the device.

### 9.1 Over load and Over temperature

When either an Over Load or an Over Temperature occurs on one channel, the diagnosis bit `DIAG_OVC_OVT` is set accordingly. The channel latches OFF and must be reactivated setting corresponding `DIAG_OVC_OVT_RLWn` bit to "1". The writing operation is necessary to remove the fault as a consequence of the fact that `DIAG_OVC_OVT` register is clear on write.

### 9.2 OFF diagnosis

This diagnosis is available only in Active mode.

The device is able to detect two kind of faults in OFF, open load and short (to battery in HS configuration or to ground in LS configuration).

This diagnosis is available upon SPI request; Once the diagnosis has been started on one or more channels, a new eventual diagnosis request is ignored until the ongoing cycle is finished.

The diagnosis strategy is implemented over two different phases:

- First the IC distinguishes between faulty and no faulty condition.
- In case of trouble found in the previous step, a specific procedure is put in place to detect the nature of the fault.

The diagnosis is slightly different depending on a LS or HS configured output.

The strategy in LS configuration is reported below and referred to [Figure 15](#); the HS case is quite similar, except for the order in which pull-up and pull-down current generators are activated and for the pin involved (`SOURCEn` for a HS configured channel, `DRAINn` for a LS).

- This first phase lasts for  $t_{OFF1LS}$ .  
The current generator marked with 'pldw' (driven by `dw_on`) is active while the current generator marked as 'plup' is off..  
In this condition, if the drain voltage remains above the threshold  $V_{DS(OL)}$ , the comparator output is low which means that a load is present.  
If the drain voltage decreases below the threshold, instead, the comparator flags the presence of a fault.
- This second phase lasts for  $t_{OFF2LS}$ .  
After the first diagnosis step the output of the comparator is set to '1' if a faulty condition has been found.  
The current generator marked with 'plup' (driven by the signal `up_on`) is activated while 'pldw' is off.  
In case, after the pull-up activation, the drain voltage rises and overcomes the comparator threshold again, an Open Load fault is reported.  
If the voltage remains constant and equal to zero for the whole diagnosis time, instead, a Short to ground fault is recognized.

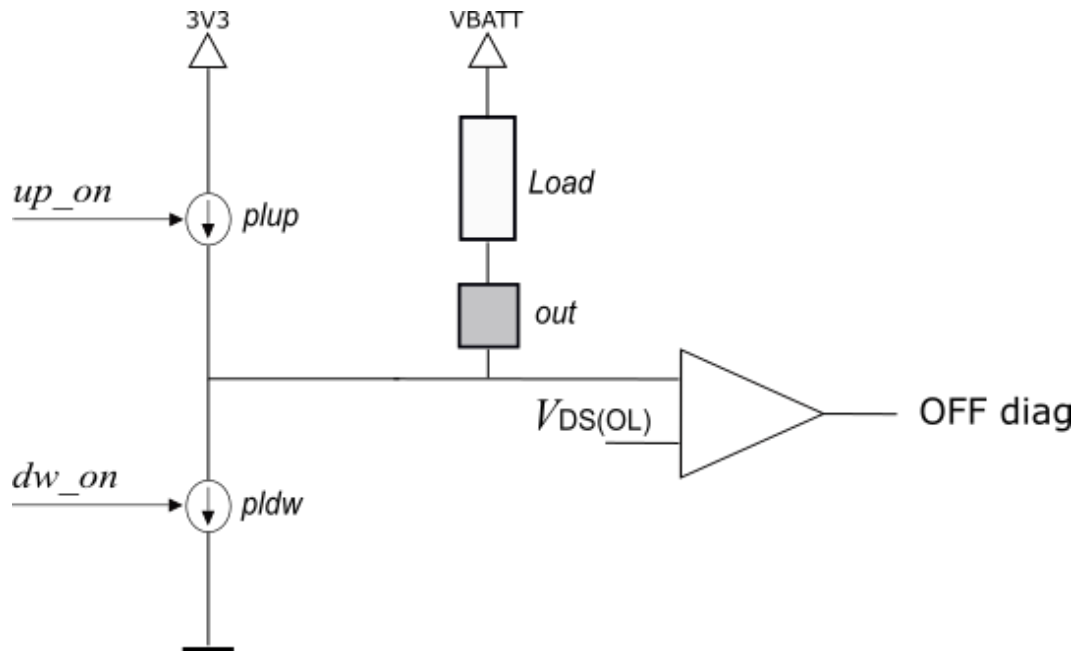
**Figure 15. OFF diagnosis circuit**

### 9.3 Open load at ON

On each channel it is possible to request the open load at on diagnosis.

This diagnosis is designed having in mind a specific case of high side channels driving LEDs kept fully ON.

Moreover, the device will ignore the request of an open load at on diagnosis in case the channel is configured as low side. This means that the request diagnosis register will not be updated in case it is requested the diagnosis on a low side configured channel.

Such a diagnosis is not recommended in case of loads driven in PWM mode (to avoid eventual interferences with the PWM driving signal) and inductive loads (to avoid unwanted power dissipations during switch OFF transients).

#### 9.3.1 Open load at ON (diagnosis mechanism)

The diagnosis cannot be run on more channels simultaneously, but it can work only on one channel at a time.

This can be activated by setting the bit corresponding to the desired channel in the DIAG\_OPL\_ON\_EN register.

During the diagnostic loop the channel is switched off every  $t_{OPLCYC}$  for a maximum time of  $t_{OPLEN}$ .

Such a time is designed to be short enough to result in a negligible variation of the luminescence of LED during the test.

During the short switch-off time required to perform the diagnosis a pull-up current generator  $I_{L(OL)}$  is applied to the source of the channel, as can be seen from Figure 16.

If the load is present the source voltage drops suddenly, the output of the comparator is set and channel immediately restarts.

If an open load condition exists, instead, the pull-up current  $I_{L(OL)}$  is capable of keeping the source voltage to battery and the  $V_{ds}$  value remains stable for the whole diagnosis time interval.

In this case once  $t_{OPLEN}$  is elapsed, the comparator output is still low and the flag related to the fault is set; the channel is anyway restarted.

The OPL ON diagnosis lasts just a  $t_{OPLEN}$  time in the worst case scenario, i.e. when the open load is detected.

Once an SPI frame commanding the diagnostic is received, the diagnosis will start a  $T_{Oplcyc}$  time after the corresponding request has been accepted.

As long as the diagnosis request bit remains high the open load test will be performed every  $T_{Oplcyc}$  and the results of the diagnosis will be reported in the register DIAG\_OPL\_ON: if an open load on channel 'n' is detected, the corresponding bit DIAG\_OPL\_ONn is set.



The OPL ON diagnosis can be performed only if the DIAG\_OVC\_OVT.OUTn flag is not asserted and can be run only on a single channel for each diagnostic cycle: an eventual diagnostic cycle performing OPL ON on multiple channels will not be executed and SPI command will have no effect.

Once the current diagnostic cycle is over, a new cycle can be started with OPL ON diagnosis requested for a different channel.

Figure 16. Open load at ON circuit

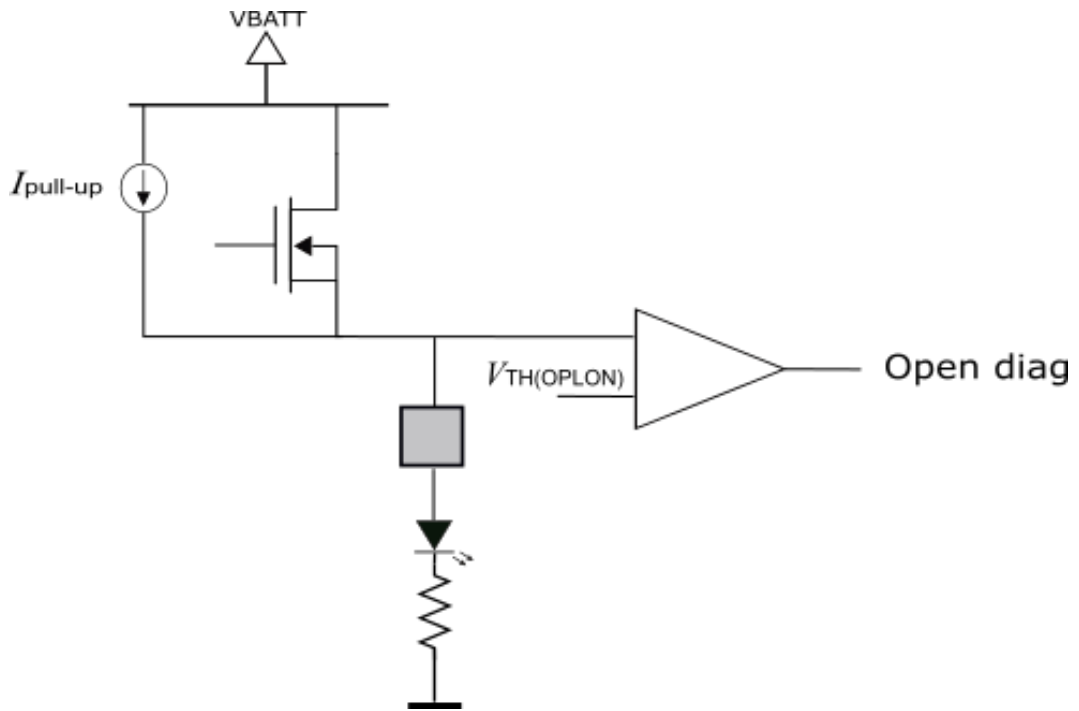

### 9.3.2 Open load at ON bit

In the DIAG\_OPL\_ON register there are 8 bits that can assume the following values:

- “0” = no Open Load at ON state detected, or the channel is OFF when the diagnosis is performed
- “1” = Open Load at ON state detected

This register is clear on read. An SPI read is necessary to clear the faulty information.

Once the DIAG\_OPL\_ON flag is set, it remains asserted until a new diagnostic cycle is completed when the fault is no longer present, and the diagnostic register is read through SPI.

## 9.4 Electrical parameters

3 V ≤ VDDIO ≤ 5.5; 6 V ≤ VBATT ≤ 18 V; -40 °C ≤ Tj ≤ 150 °C unless otherwise noticed. All voltages are referred to GND pin.

**Table 17. Output status and open load ON electrical parameters**

Symbol	Description	Test condition	Min	Typ	Max	Unit
<b>Output status monitor</b>						
V <sub>DS(OL)</sub>	Output Status Monitor threshold voltage	VBATT = 14 V; Active	1.7	1.95	2.2	V
I <sub>OLD_LS</sub>	Output diagnosis pull down current (channels used as Low Side)	V <sub>DRAIN</sub> = 14V (channels used as Low Side)	290	-	550	μA
I <sub>OLU_LS</sub>	Output diagnosis pull up current (channels used as Low Side)	V <sub>DRAIN</sub> = 0 V (channels used as Low Side)	-260	-	-140	μA
I <sub>OLD_HS</sub>	Output diagnosis pull down current (channels used as High Side)	V <sub>SOURCE</sub> = 14 V (channels used as High Side)	320	-	520	μA
I <sub>OLU_HS</sub>	Output diagnosis pull up current (channels used as High Side)	V <sub>SOURCE</sub> = 0 V (channels used as High Side)	-310	-	-160	μA
<b>Open load at ON</b>						
t <sub>OPLCYC</sub>	Open Load at ON Diagnosis cycle time	Covered by SCAN	120	160	210	ms
t <sub>OPLEN</sub>	Open Load at ON Diagnosis time	Covered by SCAN	30	45	55	μs
t <sub>OFF1LS</sub>	Diag OFF LS first window	Covered by SCAN	0.96	1.03	1.28	ms
t <sub>OFF2LS</sub>	Diag OFF LS second window	Covered by SCAN	210	250	290	μs
t <sub>OFF1HS</sub>	Diag OFF HS first window	Covered by SCAN	210	250	290	μs
t <sub>OFF2HS</sub>	Diag OFF HS second window	Covered by SCAN	0.96	1.03	1.28	ms
V <sub>TH(OPLON)</sub>	Voltage threshold for HS OPL ON Diagnosis at VS pin	Active mode	V <sub>Drain-1.3</sub>	V <sub>Drain-1.2</sub>	V <sub>Drain-1.1</sub>	V
I <sub>TH(OPLON)</sub>	Current provided by the source while forcing VBAT-3V on Source pin	VS = VBAT-3 V; Active mode	1.2	-	2	mA

## 10 Limp Home mode

The Limp is intended to handle limited functionality of the device in critical faulty situations.

A typical application scenario is reported in Figure 17, with a system which is reconfigured during Limp Home as shown in Figure 18.

Shall the micro that controls the device fail, an external safety micro takes over controlling parallel inputs IN0 and IN1. The SBC will force the IDLE signal low which brings the device in Limp Home. Once the switching activity on IN0, IN1 is over, being the IDLE pin still de-asserted, the device will reach Sleep mode.

During this mode active, L9026 is only capable of driving two outputs i.e. OUT2 through IN0 and OUT3 through IN1; such a mapping is fixed and overcomes an eventual different mapping programmed via SPI once the Limp Home is reached.

Figure 17. Possible system configuration during normal operating conditions

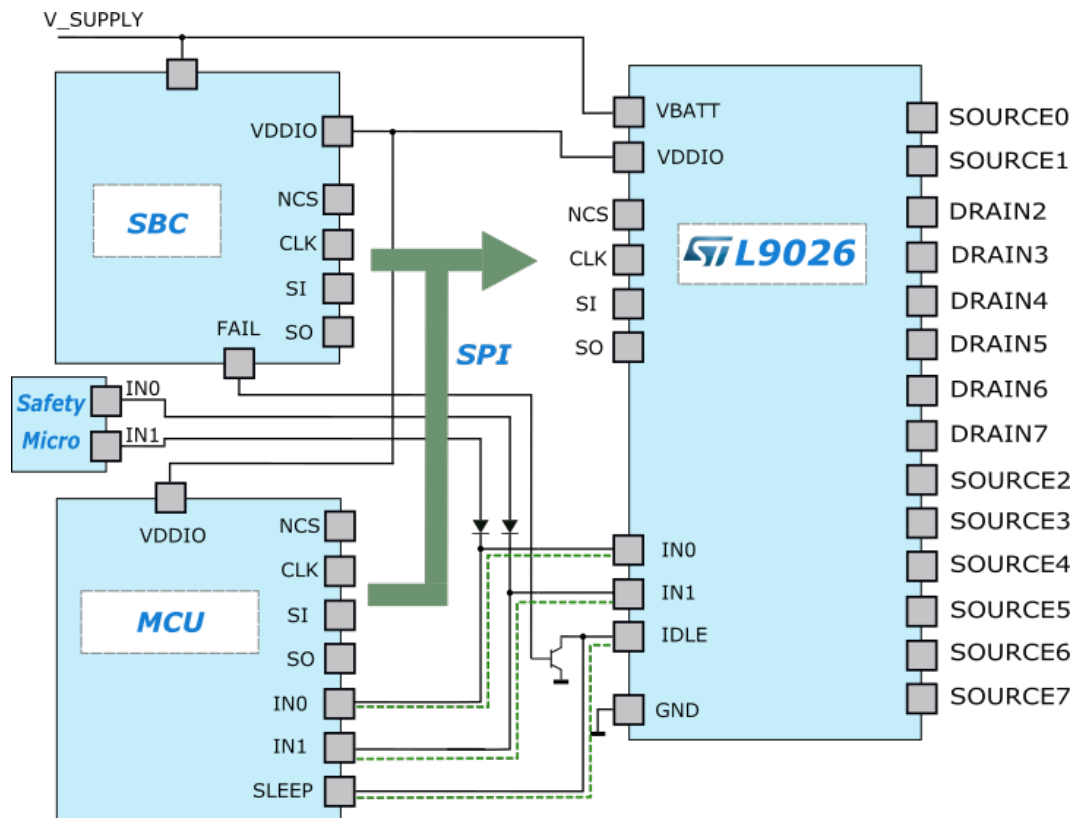

In Figure 17 the dotted green lines mark the signals path when the device is operating in normal node, IDLE, IN0, IN1 are provided by the main MCU. Figure 18 shows a possible Limp Home configuration where the dotted blue lines mark the signals path.

Figure 18. Possible system configuration during Limp mode

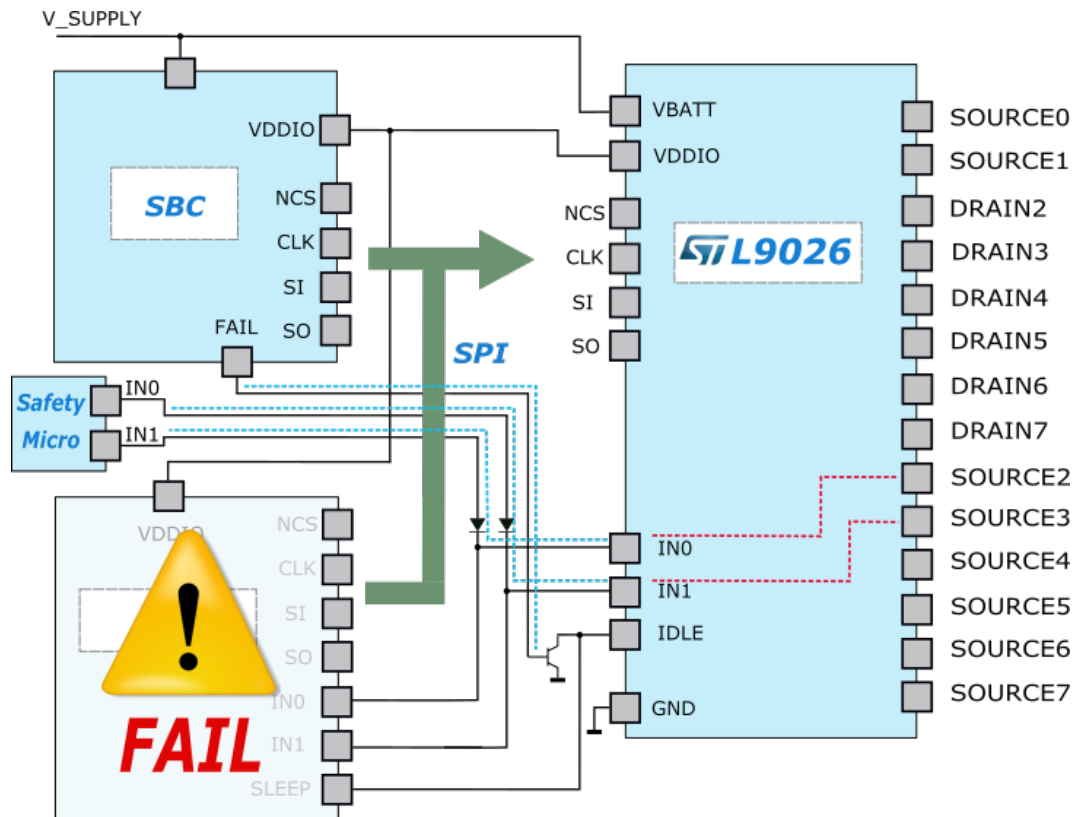

## 11 SPI

The SPI interface is used to configure the device, control the outputs and read diagnostic and status registers.

### 11.1 SPI protocol

The serial peripheral interface (SPI) is a full duplex synchronous serial out-of-frame slave interface, with four lines: SO, SI, CLK and NCS. Data is transferred by the lines MOSI and MISO at the rate given by CLK.

Considering the out-of-frame protocol implemented, it is important to ignore the first MISO received at the start of communication because it is meaningless.

The falling edge of NCS defines the start of the SPI frames. L9026 samples the MOSI line (SI) at the rising edge of CLK while the output data is shifted out on line MISO (SO) at the falling edge of CLK. (CPOL='0', CPHA = '0'). End of SPI access is defined by a rising edge of NCS.

L9026 implements feature to guarantee that SPI frame is considered valid when at least 16 bits have been transferred: in case of transaction with less than 16 bit is received, the frame will be discarded and ERR bit is asserted in next SPI frame. An SPI access with frame longer than 16 bits will be not discarded in order to allow daisy chain operation.

As additional safety feature, the protocol is also equipped with 1 PARITY bit (odd parity) and a 1 bit frame counter; the frame counter value to be considered at the beginning of a new communication session after a reset action is "0". In case an incorrect frame counter value is detected, ERR bit is asserted in next SPI frame. The detailed structure of MOSI and MISO frames is shown in [Section 11.5 SPI frame structure](#).

The relationship between MOSI and MISO content during SPI communication is shown in [Figure 19](#): the protocol implements an out-of-frames strategy.

Figure 19. SPI out-of-frame protocol

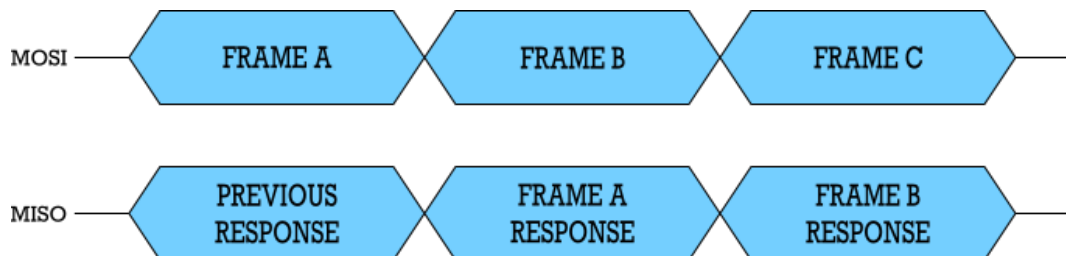

During the Limp Home the SPI is in read only mode while no SPI access is possible during device Sleep Mode: eventual frames are ignored and MISO pin remains in high impedance.

## 11.2 Daisy chain capability

L9026 implements SPI with daisy chain capability where a single master can address multiple slaves by driving a single NCS and MOSI lines, getting back data from a single MISO line as reported in the [Figure 20](#).

Figure 20. SPI Daisy chain configuration

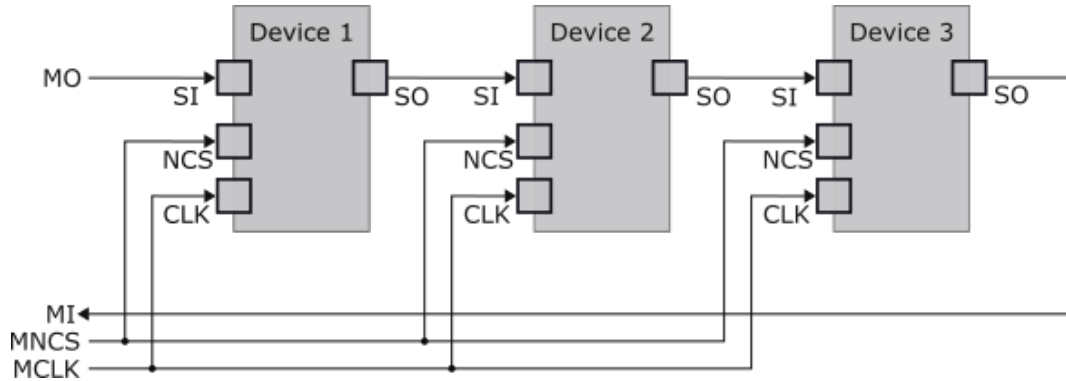

In order to gain flexibility, the daisy chain approach can be used not only to address multiple L9026 but the IC allows addressing also mixed configurations, provided that all the elements of the chain work with CPOL = 0, CPHA = 0.

As reported in [Figure 21](#), the only condition to be met is that the frame loaded inside each device of the chain is consistent and error free once the MNCS is de-asserted.

Figure 21. SPI message in daisy chain configuration

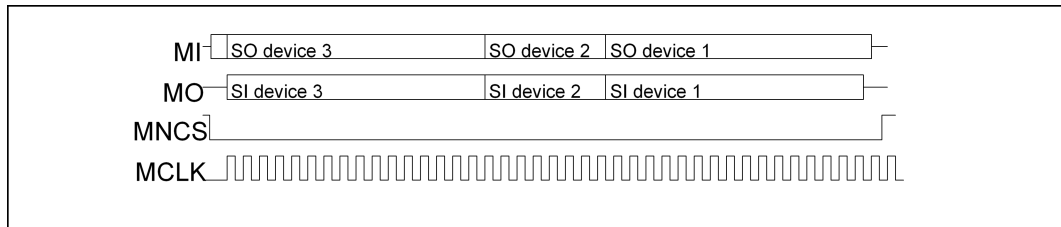

## 11.3 SPI electrical specifications

3 V ≤ VDDIO ≤ 5.5 V; 6 V ≤ VBATT ≤ 18 V; -40 °C ≤ Tj ≤ 150 °C unless otherwise noticed. All voltages are referred to GND pin.

Table 18. SPI electrical parameters

Parameter	Description	Test condition	Min	Typ	Max	Unit
Input SPI pins – low level						
V <sub>NCS(L)</sub>	NCS	-	-	-	0.8	V
V <sub>CLK(L)</sub>	CLK	-	-	-	0.8	V
V <sub>SI(L)</sub>	SI	-	-	-	0.8	V
Input SPI pins – high level						
V <sub>NCS(H)</sub>	NCS	-	2	-	-	V
V <sub>CLK(H)</sub>	CLK	-	2	-	-	V
V <sub>SI(H)</sub>	SI	-	2	-	-	V

Parameter	Description	Test condition	Min	Typ	Max	Unit
<b>Input pull up resistor at NCS pin</b>						
R <sub>NCS</sub>	L-input pull-up resistor at NCS pin	V <sub>NCS</sub> = 0.8 V	40	58	95	KΩ
<b>Input pull down resistor at pin</b>						
R <sub>CLK</sub>	Input pull-down resistor on CLK	V <sub>CLK</sub> = 2 V	70	-	140	KΩ
R <sub>SI</sub>	Input pull-down resistor on SI	V <sub>SI</sub> = 2 V	70	-	140	KΩ
<b>Output characteristics</b>						
V <sub>SO(L)</sub>	L level output voltage	I <sub>SO</sub> = -1.5 mA	0	-	0.4	V
V <sub>SO(H)</sub>	H level output voltage	I <sub>SO</sub> = 1.5 mA	VDDIO - 0.4	-	VDDIO	V
I <sub>SO(OFF)</sub>	Output tristate leakage current	V <sub>NCS</sub> = VDDIO V <sub>BATT</sub> = 0 V	-1	-	1	μA
I <sub>SO(OFF)</sub>	Output tristate leakage current	V <sub>NCS</sub> = VDDIO V <sub>BATT</sub> = VDDIO	-1	-	1	μA
<b>Timings</b>						
t <sub>CSN(lead)</sub>	Enable lead time (falling NCS to rising CLK)	VDDIO = 4.5 V or V <sub>BATT</sub> > 7 V	200	-	-	ns
t <sub>CSN(lag)</sub>	Enable lag time (falling CLK to rising NCS)	VDDIO = 4.5 V or V <sub>BATT</sub> > 7 V	200	-	-	ns
t <sub>CSN(td)</sub>	Transfer delay time (rising NCS to falling NCS)	VDDIO = 4.5 V or V <sub>BATT</sub> > 7 V	650	-	-	ns
t <sub>SO(en)</sub>	Output enable time (falling NCS to SO valid)	VDDIO = 4.5 V or V <sub>BATT</sub> > 7 V; C <sub>L</sub> = 20 pF at MISO pin	-	-	200	ns
t <sub>SO(dis)</sub>	Output disable time (rising NCS to SO tristate)	VDDIO = 4.5 V or V <sub>BATT</sub> > 7 V; C <sub>L</sub> = 20 pF at MISO pin	-	-	200	ns
f <sub>SCLK</sub>	Serial clock frequency	VDDIO = 4.5 V or V <sub>BATT</sub> > 7 V	-	-	8	MHz
t <sub>SCLK(H)</sub>	Serial clock "high" time	VDDIO = 4.5 V or V <sub>BATT</sub> > 7 V	45	-	-	ns
t <sub>SCLK(L)</sub>	Serial clock "low" time	VDDIO = 4.5 V or V <sub>BATT</sub> > 7 V	45	-	-	ns
t <sub>SI(su)</sub>	Data setup time (required time MOSI to falling CLK)	VDDIO = 4.5 V or V <sub>BATT</sub> > 7 V	30	-	-	ns
t <sub>SI(h)</sub>	Data hold time (falling CLK to SI)	VDDIO = 4.5 V or V <sub>BATT</sub> > 7 V	30	-	-	ns

## 11.4 SPI timing diagram

Figure 22. SPI timing diagrams

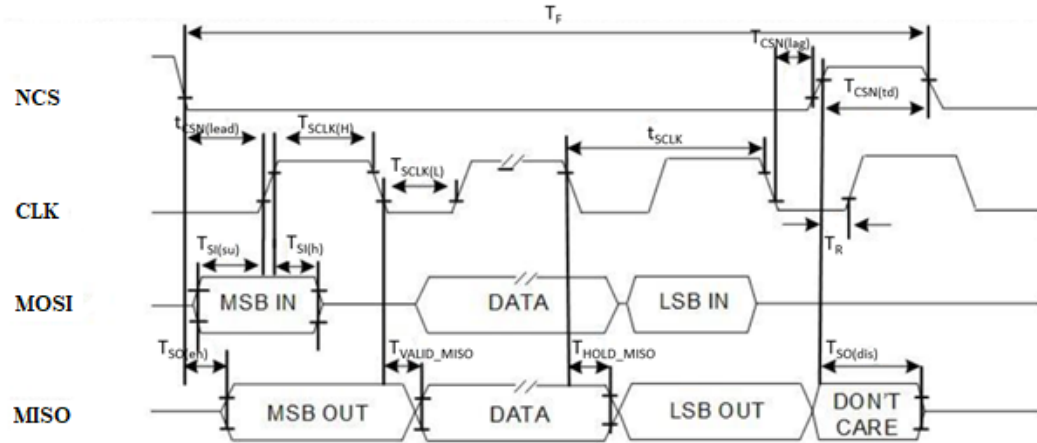

## 11.5 SPI frame structure

### 11.5.1 MOSI frame structure

Each MOSI frame has 16 bits with the following structure:

- 1 command bit R/W, '1' for write, '0' for read
- 5 ADDRESS bits
- 8 DATA bits
- 1 PARITY bit, odd parity, calculated on bit [2:15]
- 1 FR\_CNT frame counter bit

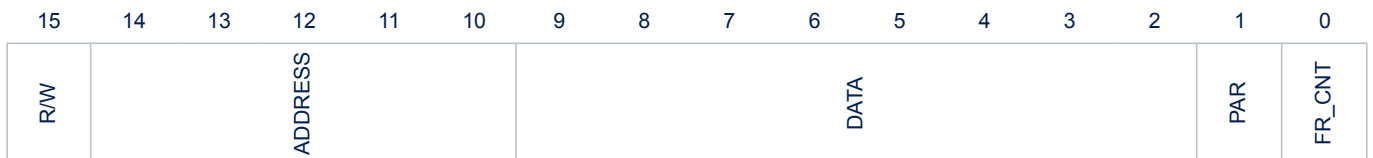

### 11.5.2 MISO frame structure

Each MISO frame has 16 bits with the following structure:

- 1 ERR error bit, '1' if an error happened in the previous transmission, '0' otherwise
- 5 ADDRESS bits
- 8 DATA bits
- 1 PARITY bit, odd parity, calculated on bit [2:15]
- 1 FR\_CNT frame counter bit





## 11.6 SPI register

### 11.6.1 Register structure CHIP\_ID

<b>Register name:</b>	CHIP_ID
<b>Address:</b>	Global Base Address + 0x00
<b>Description:</b>	Chip ID register

Field name	Type	Bit Offset	Bit Width	Reset Value	Reset Sources	Description
CHIP_ID	RO	0	8	AA Bit 0->7 00100010 BA Bit 0->7 00101010 BB Bit 0->7 01010101	X	8 bit chip identifier

### CFG\_0

<b>Register name:</b>	CFG_0
<b>Address:</b>	Global Base Address + 0x01
<b>Description:</b>	Configuration 0

Field name	Type	Bit Offset	Bit Width	Reset Value	Reset Sources	Description
OUTn	RW	2	6	0x00	POR_N, NRES pin, CFG_1.RST bit, VDD_UV	Channel [7:2], MSB refers to channel 7 0: (default) OUTn low side 1: OUTn high side
DIS_EN	RW	1	1	0x00	POR_N, NRES pin, CFG_1.RST bit, VDD_UV	0: (default) DIS pin masked 1: DIS pin not masked
NRES_EN	RW	0	1	0x00	POR_N, NRES pin, CFG_1.RST bit, VDD_UV	0: (default) NRES pin masked 1: NRES pin not masked

### CFG\_1

<b>Register name:</b>	CFG_1
<b>Address:</b>	Global Base Address + 0x02
<b>Description:</b>	Configuration 1

Field name	Type	Bit Offset	Bit Width	Reset Value	Reset Sources	Description
RST	WO	7	1	0x00	POR_N, NRES pin, CFG_1.RST bit, VDD_UV	Reset 0: (default) Normal operation 1: Execute Reset command (self clearing)
ACT	RW	6	1	0x00	POR_N, NRES pin, CFG_1.RST bit, VDD_UV	active mode 0: (default) Normal operation or device leaves Active Mode 1: device enters and hold in Active Mode
NU	RO	2	4	0x00	X	-

PWM_DIV_LED	RW	0	2	0x00	POR_N, NRES pin, CFG_1.RST bit, VDD_UV	00: (default) PWM_FRQ=122.5Hz 01: PWM_FRQ=245.1Hz 10: PWM_FRQ=490.2Hz 11: PWM_FRQ=980.4Hz
-------------	----	---	---	------	--	---

### CFG\_2

<b>Register name:</b>	CFG_2
<b>Address:</b>	Global Base Address + 0x03
<b>Description:</b>	Configuration 2

Field name	Type	Bit Offset	Bit Width	Reset Value	Reset Sources	Description
NU	RO	4	4	0x00	X	-
FR_ADJ	RW	2	2	0x00	POR_N, NRES pin, CFG_1.RST bit, VDD_UV	00: NO FREQ ADJUSTMENT 01: -15% ON SELECTED FREQUENCY 10: +15% ON SELECTED FREQUENCY 11: NO FREQ ADJUSTMENT
PWM_DIV_GEN	RW	0	2	0x00	POR_N, NRES pin, CFG_1.RST bit, VDD_UV	00: (default) PWM_FRQ=122.5Hz 01: PWM_FRQ=245.1Hz 10: PWM_FRQ=490.2Hz 11: PWM_FRQ=980.4Hz

### BIM

<b>Register name:</b>	BIM
<b>Address:</b>	Global Base Address + 0x04
<b>Description:</b>	Bulb Inrush Mode register configuration

Field name	Type	Bit Offset	Bit Width	Reset Value	Reset Sources	Description
OUTn	RW	0	8	0x00	POR_N, NRES pin, CFG_1.RST bit, VDD_UV	Channel [7:0], MSB refers to channel 7 0: (default) no BIM active 1: BIM active

### RESERVED\_1

<b>Register name:</b>	RESERVED_1
<b>Address:</b>	Global Base Address + 0x05
<b>Description:</b>	Reserved

Field name	Type	Bit Offset	Bit Width	Reset Value	Reset Sources	Description
UNUSED	RO	0	8	0x00	X	-

### PWM\_SPI

<b>Register name:</b>	PWM_SPI
<b>Address:</b>	Global Base Address + 0x06

<b>Description:</b>	Power output control register
---------------------	-------------------------------

Field name	Type	Bit Offset	Bit Width	Reset Value	Reset Sources	Description
OUTn	RW	0	8	0x00	POR_N, NRES pin, CFG_1.RST bit, VDD_UV	Channel [7:0], MSB refers to channel 7 0: (default) Output OFF 1: Output ON

### MAP\_IN0

<b>Register name:</b>	MAP_IN0
<b>Address:</b>	Global Base Address + 0x07
<b>Description:</b>	IN0 input mapping register

Field name	Type	Bit Offset	Bit Width	Reset Value	Reset Sources	Description
OUTn	RW	0	8	0x04 OUT2 mapped on IN0	POR_N, NRES pin, CFG_1.RST bit, VDD_UV	Channel [7:0], MSB refers to channel 7 0: OUTn not driven by IN0 1: OUTn driven by IN0

### MAP\_IN1

<b>Register name:</b>	MAP_IN1
<b>Address:</b>	Global Base Address + 0x08
<b>Description:</b>	IN1 input mapping register

Field name	Type	Bit Offset	Bit Width	Reset Value	Reset Sources	Description
OUTn	RW	0	8	0x08 OUT3 mapped on IN1	POR_N, NRES pin, CFG_1.RST bit, VDD_UV	Channel [7:0], MSB refers to channel 7 0: OUTn not driven by IN1 1: OUTn driven by IN1

### MAP\_PWM

<b>Register name:</b>	MAP_PWM
<b>Address:</b>	Global Base Address + 0x09
<b>Description:</b>	Internal PWM generator mapping register

Field name	Type	Bit Offset	Bit Width	Reset Value	Reset Sources	Description
OUTn	RW	0	8	0x00	POR_N, NRES pin, CFG_1.RST bit, VDD_UV	Channel [7:0], MSB refers to channel 7 0: OUTn not driven by internal PWM generator 1: OUTn driven by internal PWM generator

### PWM\_SEL

<b>Register name:</b>	PWM_SEL
<b>Address:</b>	Global Base Address + 0x0A
<b>Description:</b>	Internal PWM generator selection register

Field name	Type	Bit Offset	Bit Width	Reset Value	Reset Sources	Description
OUTn	RW	0	8	0x00	POR_N, NRES pin, CFG_1.RST bit, VDD_UV	Channel [7:0], MSB refers to channel 7 0: (default) PWM_GEN selected for OUTn 1: PWM_LED selected for OUTn

### PWM\_GEN\_DC

<b>Register name:</b>	PWM_GEN_DC
<b>Address:</b>	Global Base Address + 0x0B
<b>Description:</b>	PWM GEN duty cycle setting

Field name	Type	Bit Offset	Bit Width	Reset Value	Reset Sources	Description
DUTY_CYCLE	RW	0	8	0x00	POR_N, NRES pin, CFG_1.RST bit, VDD_UV	b00000000, PWM GEN OFF b11111111, PWM GEN fully ON duty = 100/255*LSB

### PWM\_LED\_DC

<b>Register name:</b>	PWM_LED_DC
<b>Address:</b>	Global Base Address + 0x0C
<b>Description:</b>	PWM LED duty cycle setting

Field name	Type	Bit Offset	Bit Width	Reset Value	Reset Sources	Description
DUTY_CYCLE	RW	0	8	0x00	POR_N, NRES pin, CFG_1.RST bit, VDD_UV	b00000000, PWM GEN OFF b11111111, PWM GEN fully ON duty = 100/255*LSB

### DIAG\_OFF\_EN

<b>Register name:</b>	DIAG_OFF_EN
<b>Address:</b>	Global Base Address + 0x0D
<b>Description:</b>	OFF Diagnostic enable register

Field name	Type	Bit Offset	Bit Width	Reset Value	Reset Sources	Description
OUTn	RW	0	8	0x00	POR_N, NRES pin, CFG_1.RST bit, VDD_UV	Channel [7:0], MSB refers to channel 7 0: (default) OFF diagnosis not active 1: OFF diagnosis active

### DIAG\_OPL\_ON\_EN

<b>Register name:</b>	DIAG_OPL_ON_EN
<b>Address:</b>	Global Base Address + 0x0E
<b>Description:</b>	Open Load in ON Diagnostic enable register

Field name	Type	Bit Offset	Bit Width	Reset Value	Reset Sources	Description
OUTn	RW	0	8	0x00	POR_N, NRES pin, CFG_1.RST bit, VDD_UV	Channel [7:0], MSB refers to channel 7 0: (default) OL diagnosis not active 1: OL diagnosis active

### DIAG\_OVC\_OVT\_RLW

<b>Register name:</b>	DIAG_OVC_OVT_RLW
<b>Address:</b>	Global Base Address + 0x0F
<b>Description:</b>	Overcurrent/overtemperature error Clear on write

Field name	Type	Bit Offset	Bit Width	Reset Value	Reset Sources	Description
OUTn	WO	0	8	0x00	POR_N, NRES pin, CFG_1.RST bit, VDD_UV	Channel [7:0], MSB refers to channel 7 0: (default) clear on write not active 1: clear on write active

### STA\_0

<b>Register name:</b>	STA_0
<b>Address:</b>	Global Base Address + 0x10
<b>Description:</b>	Status Register 0

Field name	Type	Bit Offset	Bit Width	Reset Value	Reset Sources	Description
NU	RO	7	1	0x00	X	-
DIS	RO	6	1	0x00	POR_N	Echo status of DIS input (if properly configured)
X	-	5	1	X	X	-
IDLE	RO	4	1	0x00	POR_N	Echo status of IDLE input
IN1	RO	3	1	0x00	POR_N	Echo status of IN1 input
IN0	RO	2	1	0x00	POR_N	Echo status of IN0 input
OUT_ON_ERR	RLR	1	1	0x00	POR_N	0: normal 1: overcurr/overtemp detected on a whatever channel
OUT_OFF_ERR	RLR	0	1	0x00	POR_N	0: normal 1: OFF state diag fail on whatever channel

### STA\_1

<b>Register name:</b>	STA_1
<b>Address:</b>	Global Base Address + 0x11
<b>Description:</b>	Status Register 1

Field name	Type	Bit Offset	Bit Width	Reset Value	Reset Sources	Description
NU	RO	5	3	0x00	X	-
POR	RLR	4	1	0x00	POR_N	0: POR condition not detected 1: POR condition detected
VDDIO_UV	RLR	3	1	0x00	POR_N	0: no VDDIO undervoltage 1: VDDIO undervoltage detected
VBATT_UV	RLR	2	1	0x00	POR_N	0: no VBATT undervoltage 1: VBATT undervoltage detected
MODE	RO	0	2	0x00	POR_N	IC operating mode 00: Sleep Mode 01: Limp Home Mode 10: Idle Mode 11: Active Mode

#### DIAG\_OVC\_OVT

<b>Register name:</b>	DIAG_OVC_OVT
<b>Address:</b>	Global Base Address + 0x12
<b>Description:</b>	Overcurrent/overtemperature detection Register

Field name	Type	Bit Offset	Bit Width	Reset Value	Reset Sources	Description
OUTn	RLW	0	8	0x00	POR_N	Channel [7:0], MSB refers to channel 7 0: (default) no fail 1: overcurr/overtemp detected

#### DIAG\_OPL\_OFF

<b>Register name:</b>	DIAG_OPL_OFF
<b>Address:</b>	Global Base Address + 0x13
<b>Description:</b>	Driver Open load detection in off state Register

Field name	Type	Bit Offset	Bit Width	Reset Value	Reset Sources	Description
OUTn	RLR	0	8	0x00	POR_N	Channel [7:0], MSB refers to channel 7 0: (default) no fail 1: open load detected

#### DIAG\_OPL\_ON

<b>Register name:</b>	DIAG_OPL_ON
-----------------------	-------------

<b>Address:</b>	Global Base Address + 0x14
<b>Description:</b>	Driver Open load detection in on state Register

Field name	Type	Bit Offset	Bit Width	Reset Value	Reset Sources	Description
OUTn	RLR	0	8	0x00	POR_N	Channel [7:0], MSB refers to channel 7 0: (default) no fail 1: open load detected

### DIAG\_SHG

<b>Register name:</b>	DIAG_SHG
<b>Address:</b>	Global Base Address + 0x15
<b>Description:</b>	Driver shorted load detection in OFF state Register

Field name	Type	Bit Offset	Bit Width	Reset Value	Reset Sources	Description
OUTn	RLR	0	8	0x00	POR_N	Channel [7:0], MSB refers to channel 7 0: (default) no fail 1: STG/STB detected

*Note:* Global Base Address to be considered as 0x00

## 12 Package information

In order to meet environmental requirements, ST offers these devices in different grades of **ECOPACK** packages, depending on their level of environmental compliance. ECOPACK specifications, grade definitions and product status are available at: [www.st.com](http://www.st.com). ECOPACK is an ST trademark.

### 12.1 VFQFPN32 (5x5x1 mm exp. pad down 3.5x3.5) package information

Figure 23. VFQFPN32 (5x5x1 mm exp. pad down 3.5x3.5) package outline

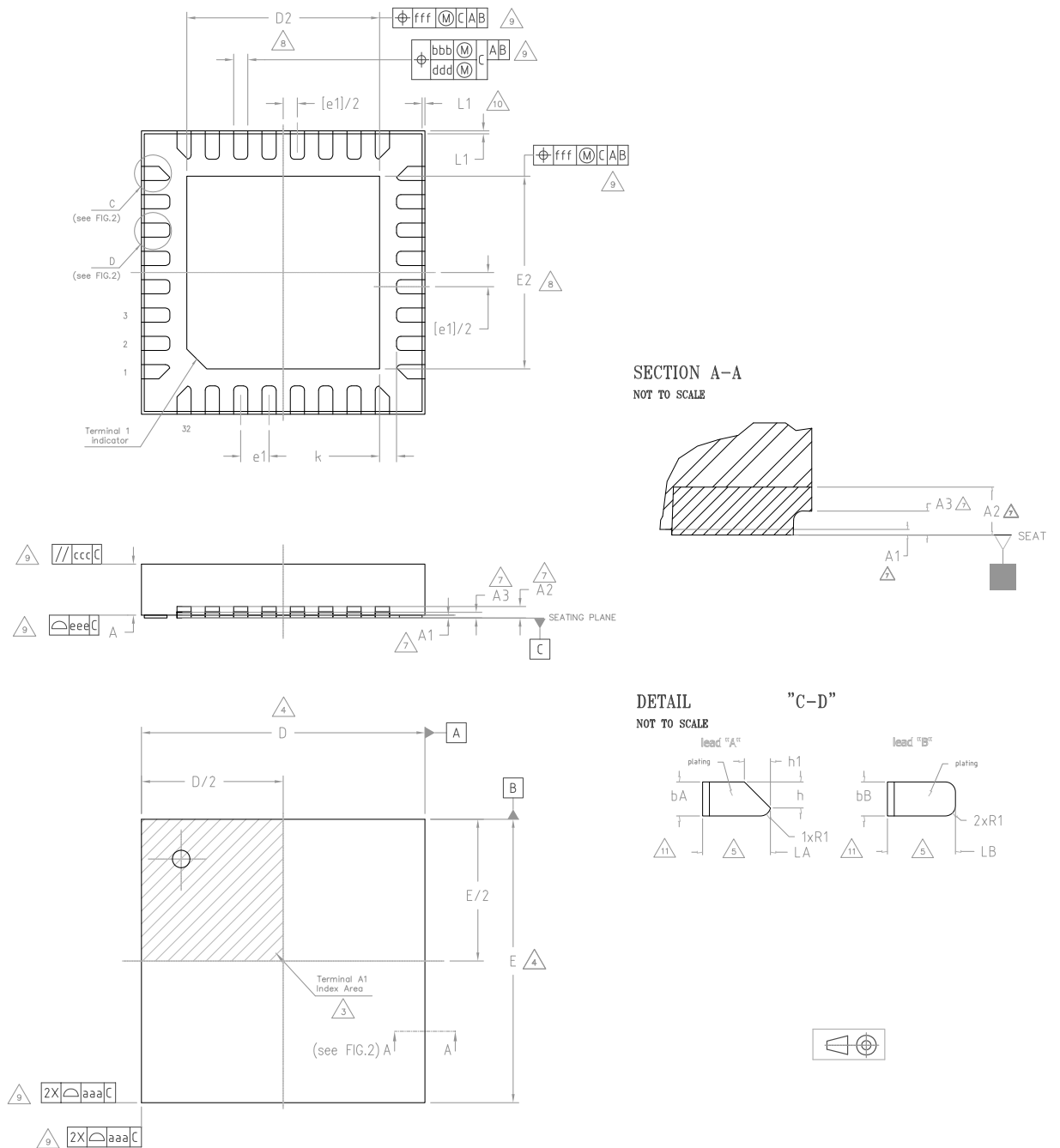

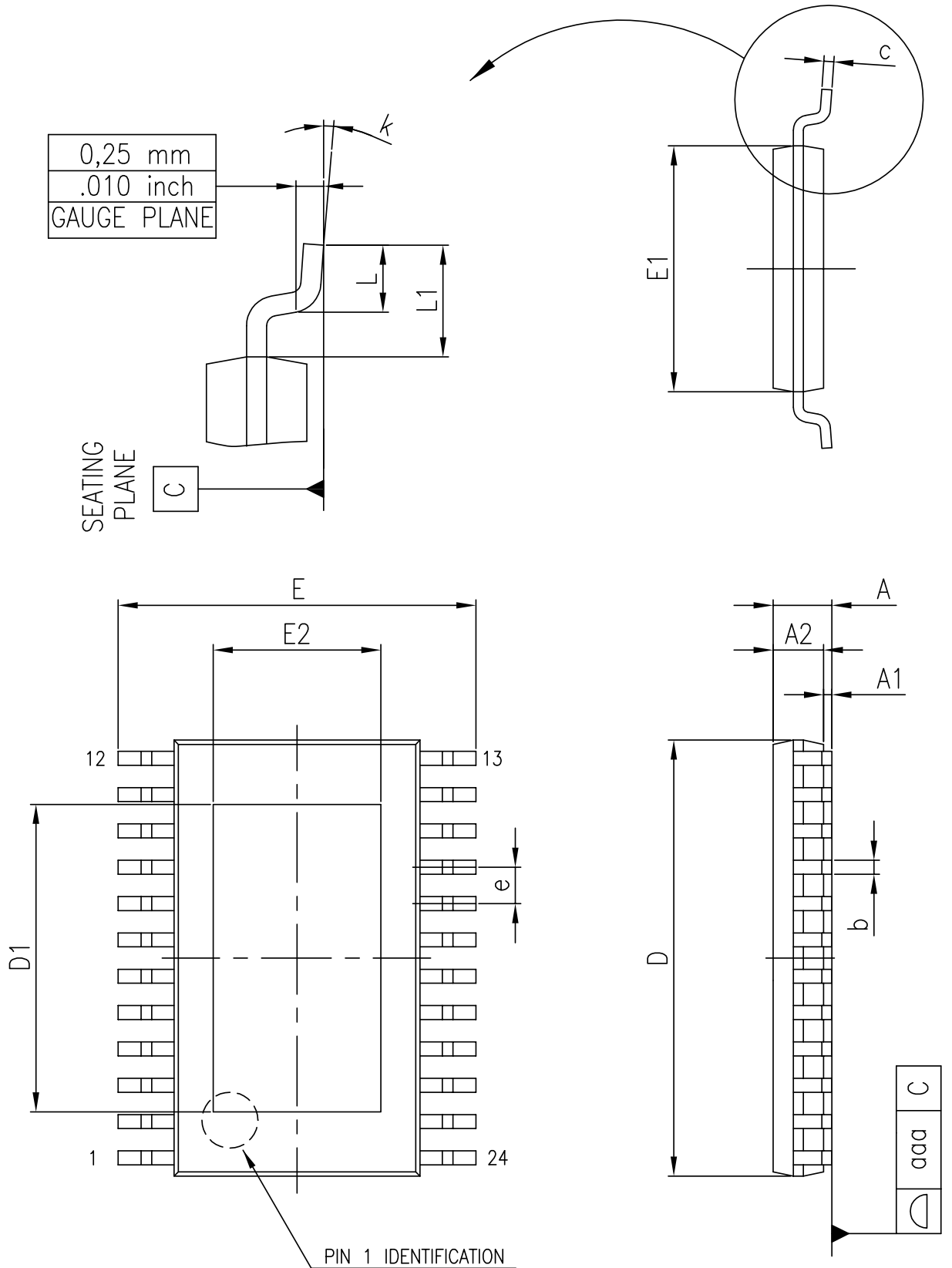

**Table 19. VFQFPN32 (5x5x1 mm exp. pad down 3.5x3.5) mechanical data**

Symbol	Dimensions			Note
	Min	Typ	Max	
A	0.80	0.90	1.00	
A1	0.00	-	0.05	
A2	0.2 REF			
A3	0.1	-	-	
D	5.00 BSC			4
D2	3.40	3.50	3.60	8
E	5.00 BSC			4
E2	3.40	3.50	3.60	8
e1	0.5 BSC			
k	0.20	-	-	
L1	-	-	0.05	10
La	0.40	0.50	0.60	11
bA	0.20	0.25	0.30	11
h	0.19 REF			11
h1	0.19 REF			11
LB	0.45	0.50	0.55	11
bB	0.20	0.25	0.30	11
N	32			6
R1	-	-	0.1	
<b>Tolerance of form and position</b>				
aaa	0.15			1, 2
bbb	0.10			
ccc	0.10			
ddd	0.05			
eee	0.08			
fff	0.10			

**Notes:**

1. Dimensioning and tolerancing schemes conform to ASME Y14.5M-1994.
2. All Dimensions are in millimeters.
3. Terminal A1 identifier and terminal numbering convention shall conform to JEP95 SPP-002. Terminal A1 identifier must be located within the zone indicated on the outline drawing. Topside terminal A1 indicator may be a molded, or metalized feature. Optional indicator on bottom surface may be a molded, marked or metallized feature.
4. Outlines with "D" and "E" increments less than 0.5 mm should be registered as "stand alone" outlines. These outlines should use as many of the algorithms and dimensions states in the design standard as possible to insure predictability in manufacturing.
5. Inner edge of corner terminals may be chamfered or rounded in order to achieve minimum gap "k". This feature should not affect the terminal width "b", which is measured L/2 from the edge of the package body.
6. "N" is the maximum number of terminal positions for the specified body size. Depopulation is allowed, but only under the following conditions.
  - Depopulation scheme must be consistent in each quadrant of the package.
  - Non-symmetric variations should be broken out as separate mechanical outline variations, including depopulation graphics.
7. A1 is defined as the distance from the seating plane to the lowest point on the package body (standoff).
8. Dimension D2 and E2 refer to exposed pad.
9. For Tolerance of Form and Position see [Table 19](#).
10. Critical dimensions: 10.1 L1
11. Dimensions "b" and "L" are measured at terminal plating surface.
12. For Symbols, Recommended Values and Tolerances see Table below: (ACCORDING TO PACKAGE OR JEDEC SPEC IF REGISTERED)

**12.2 HTSSOP24 (7.8x6.4x1 mm exp. pad down 5.0x3.2) package information**
**Figure 24. HTSSOP24 (7.8x6.4x1 mm exp. pad down 5.0x3.2) package outline**

**Table 20. HTSSOP24 (7.8x4.4x1.1 mm exp. pad down 5.0x3.2) mechanical data**

Symbol	Dimensions			Note
	Min	Typ	Max	
A	1.05	1.10	1.20	1
A1	0.05	-	0.15	
A2	0.80	1.00	1.2	
b	0.19	-	0.30	
D	7.70	7.80	7.90	
D1	4.80	5.00	5.20	
E	6.20	6.40	6.60	
E1	4.30	4.40	4.50	2
E2	3.00	3.20	3.40	
e	0.65 BSC			
L	0.45	0.60	0.75	
L1	-	1.00	-	
K	0	-	8	Degrees
aaa	-	-	0.15	

**Notes:**

1. Very thin:  $0.80 < A \leq 1.00$  mm / Fine pitch:  $e < 1.00$ mm
2. The pin #1 identifier must be existed on the top surface of the package by using indentation mark or other feature of package body. Exact shape and size of this feature is optional.

Figure 25. HTSSOP24 (7.8x4.4x1.1 mm exp. pad down 5.0x3.2) recommended footprint

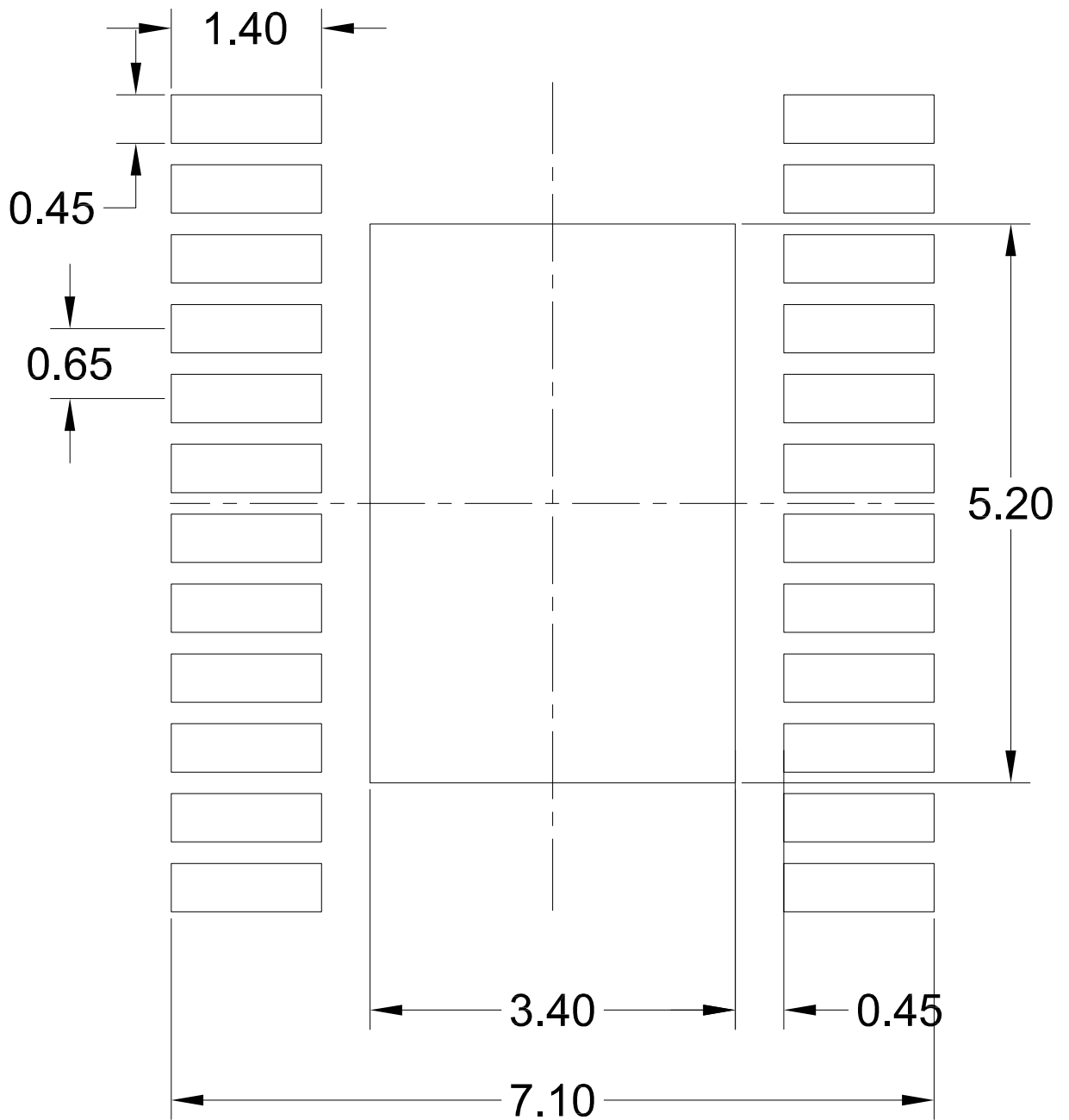

## 13 Errata

This chapter is intended to integrate the information provided in the L9026 product datasheet, in order to facilitate the correct usage of the product.

**Table 21. Errata**

#	Silicon	Function	Issue description
1	L9026BB	OFF state diagnostic	<p>OFF state diagnostic for HS configured channels shall be invoked only after <math>t_{OFF1HS}</math> is elapsed since last channel switch ON command.</p> <p>A violation of this constraint may lead to a spurious overcurrent detection and then to a shut-OFF of channels previously enabled.</p>

## Revision history

**Table 22. Document revision history**

Date	Version	Changes
06-Aug-2020	1	Initial release.
30-Sep-2020	2	Updated: <ul style="list-style-type: none"> <li>• Order Code in Product summary;</li> <li>• Table 4. Absolute maximum rating capability;</li> <li>• Table 5. Temperature range;</li> <li>• Table 8. VBATT electrical performance;</li> <li>• Table 9. Functions availability in different supply conditions;</li> <li>• Table 16. Over temperature and over load electrical parameters;</li> <li>• Table 17. Output status and open load ON electrical parameters;</li> <li>• Table 18. SPI electrical parameters.</li> </ul> Minor text changes.
09-Oct-2020	3	Added Section 13 Errata.
10-Nov-2020	4	Removed watermark "Restricted".

## Contents

<b>1</b>	<b>Block diagram</b> .....	<b>2</b>
<b>2</b>	<b>Application circuit</b> .....	<b>3</b>
<b>3</b>	<b>Pins description</b> .....	<b>5</b>
<b>4</b>	<b>Product characteristics</b> .....	<b>9</b>
4.1	Absolute maximum ratings .....	9
4.2	Latchup trials .....	9
4.3	Temperature range .....	10
<b>5</b>	<b>Input / Output</b> .....	<b>11</b>
5.1	Parallel inputs (IN0, IN1) .....	11
5.2	Idle pin (IDLE) .....	11
5.3	Reset pin (NRES, only in VFQFPN32 package option) .....	11
5.4	Enable (DIS, only in VFQFPN32 package option) .....	11
5.5	SPI communications (NCS, CLK, SI & SO) .....	11
5.6	Input / output electrical specifications .....	12
<b>6</b>	<b>Power supply</b> .....	<b>13</b>
6.1	Overview .....	13
6.2	Battery supply (VBATT) .....	13
6.3	Operating modes .....	14
6.4	Analog & Digital supply (VBATT) .....	16
6.5	I/O Supply (VDDIO) .....	16
6.6	Power up .....	16
6.7	Sleep mode .....	16
6.8	Idle mode .....	16
6.9	Active mode .....	16
6.10	Limp Home mode .....	17
6.11	Power supply transition .....	17
6.12	Reset .....	18
6.13	Power supply electrical specifications .....	18
<b>7</b>	<b>Power stages</b> .....	<b>20</b>



<b>7.1</b>	Operating modes .....	20
<b>7.1.1</b>	Switching resistive modes .....	20
<b>7.1.2</b>	Inductive output clamp .....	21
<b>7.1.3</b>	Maximum load inductance .....	21
<b>7.2</b>	Inverse current behavior .....	22
<b>7.3</b>	Bulb inrush mode .....	22
<b>7.4</b>	PWM generators .....	23
<b>7.4.1</b>	PWM GEN .....	23
<b>7.4.2</b>	PWM LED .....	24
<b>7.5</b>	Power stages electrical specifications .....	25
<b>8</b>	<b>Protection functions .....</b>	<b>28</b>
<b>8.1</b>	Overload protection .....	28
<b>8.2</b>	Over temperature protection .....	29
<b>8.3</b>	Over temperature and over load in Limp Home mode .....	29
<b>8.4</b>	Reverse polarity protection .....	29
<b>8.5</b>	Electrical characteristics .....	29
<b>9</b>	<b>Diagnosis .....</b>	<b>31</b>
<b>9.1</b>	Over load and Over temperature .....	31
<b>9.2</b>	OFF diagnosis .....	31
<b>9.3</b>	Open load at ON .....	32
<b>9.3.1</b>	Open load at ON (diagnosis mechanism) .....	32
<b>9.3.2</b>	Open load at ON bit .....	33
<b>9.4</b>	Electrical parameters .....	34
<b>10</b>	<b>Limp Home mode .....</b>	<b>35</b>
<b>11</b>	<b>SPI .....</b>	<b>37</b>
<b>11.1</b>	SPI protocol .....	37
<b>11.2</b>	Daisy chain capability .....	38
<b>11.3</b>	SPI electrical specifications .....	38
<b>11.4</b>	SPI timing diagram .....	40
<b>11.5</b>	SPI frame structure .....	40
<b>11.5.1</b>	MOSI frame structure .....	40

---

11.5.2	MISO frame structure .....	40
11.6	SPI register .....	41
11.6.1	Register structure .....	41
<b>12</b>	<b>Package information.....</b>	<b>48</b>
12.1	VFQFPN32 (5x5x1 mm exp. pad down 3.5x3.5) package information.....	48
12.2	HTSSOP24 (7.8x6.4x1 mm exp. pad down 5.0x3.2) package information .....	51
<b>13</b>	<b>Errata .....</b>	<b>54</b>
	<b>Revision history .....</b>	<b>55</b>

## List of tables

<b>Table 1.</b>	External components list for L9026 application circuit . . . . .	4
<b>Table 2.</b>	HTSSOP-24 pins list . . . . .	7
<b>Table 3.</b>	VFQFPN32 pins list . . . . .	8
<b>Table 4.</b>	Absolute maximum rating capability . . . . .	9
<b>Table 5.</b>	Temperature range. . . . .	10
<b>Table 6.</b>	Digital input/output electrical performance . . . . .	12
<b>Table 7.</b>	Supply ranges . . . . .	13
<b>Table 8.</b>	VBATT electrical performance . . . . .	13
<b>Table 9.</b>	Functions availability in different supply conditions . . . . .	15
<b>Table 10.</b>	Power supply electrical parameters . . . . .	18
<b>Table 11.</b>	Adjustment coefficients. . . . .	23
<b>Table 12.</b>	PWM GEN generator available frequencies. . . . .	23
<b>Table 13.</b>	PWM LED generator available frequencies . . . . .	25
<b>Table 14.</b>	Power stages electrical parameters . . . . .	25
<b>Table 15.</b>	PWM electrical parameters . . . . .	27
<b>Table 16.</b>	Over temperature and over load electrical parameters . . . . .	29
<b>Table 17.</b>	Output status and open load ON electrical parameters . . . . .	34
<b>Table 18.</b>	SPI electrical parameters . . . . .	38
<b>Table 19.</b>	VFQFPN32 (5x5x1 mm exp. pad down 3.5x3.5) mechanical data. . . . .	49
<b>Table 20.</b>	HTSSOP24 (7.8x4.4x1.1 mm exp. pad down 5.0x3.2) mechanical data . . . . .	52
<b>Table 21.</b>	Errata . . . . .	54
<b>Table 22.</b>	Document revision history . . . . .	55

## List of figures

<b>Figure 1.</b>	Block diagram . . . . .	2
<b>Figure 2.</b>	HTSSOP24 Application schematic . . . . .	3
<b>Figure 3.</b>	VFQFPN32 Application schematic. . . . .	4
<b>Figure 4.</b>	HTSSOP-24 pinout diagram . . . . .	5
<b>Figure 5.</b>	VFQFPN32 pinout diagram . . . . .	6
<b>Figure 6.</b>	State ddiagram. . . . .	15
<b>Figure 7.</b>	Transition times block diagram . . . . .	17
<b>Figure 8.</b>	HS driver (left) and LS driver (right) configuration . . . . .	20
<b>Figure 9.</b>	Switching resistive loads . . . . .	21
<b>Figure 10.</b>	Output clamp concept . . . . .	21
<b>Figure 11.</b>	Bulb inrush mode . . . . .	22
<b>Figure 12.</b>	Driving tree . . . . .	24
<b>Figure 13.</b>	Overload thresholds . . . . .	28
<b>Figure 14.</b>	Latch off in overload condition . . . . .	28
<b>Figure 15.</b>	OFF diagnosis circuit. . . . .	32
<b>Figure 16.</b>	Open load at ON circuit . . . . .	33
<b>Figure 17.</b>	Possible system configuration during normal operating conditions . . . . .	35
<b>Figure 18.</b>	Possible system configuration during Limp mode . . . . .	36
<b>Figure 19.</b>	SPI out-of-frame protocol . . . . .	37
<b>Figure 20.</b>	SPI Daisy chain configuration . . . . .	38
<b>Figure 21.</b>	SPI message in daisy chain configuration . . . . .	38
<b>Figure 22.</b>	SPI timing diagrams . . . . .	40
<b>Figure 23.</b>	VFQFPN32 (5x5x1 mm exp. pad down 3.5x3.5) package outline . . . . .	48
<b>Figure 24.</b>	HTSSOP24 (7.8x6.4x1 mm exp. pad down 5.0x3.2) package outline . . . . .	51
<b>Figure 25.</b>	HTSSOP24 (7.8x4.4x1.1 mm exp. pad down 5.0x3.2) recommended footprint . . . . .	53

**IMPORTANT NOTICE – PLEASE READ CAREFULLY**

STMicroelectronics NV and its subsidiaries (“ST”) reserve the right to make changes, corrections, enhancements, modifications, and improvements to ST products and/or to this document at any time without notice. Purchasers should obtain the latest relevant information on ST products before placing orders. ST products are sold pursuant to ST’s terms and conditions of sale in place at the time of order acknowledgement.

Purchasers are solely responsible for the choice, selection, and use of ST products and ST assumes no liability for application assistance or the design of Purchasers’ products.

No license, express or implied, to any intellectual property right is granted by ST herein.

Resale of ST products with provisions different from the information set forth herein shall void any warranty granted by ST for such product.

ST and the ST logo are trademarks of ST. For additional information about ST trademarks, please refer to [www.st.com/trademarks](http://www.st.com/trademarks). All other product or service names are the property of their respective owners.

Information in this document supersedes and replaces information previously supplied in any prior versions of this document.

© 2020 STMicroelectronics – All rights reserved