



SO-6020-MSSTL



SO-6030-MSSTL



SO-6012-MSSTL



SO-6005-MSSTL



SO-6003-MSSTL

SO-6030-WHT

SO-6020-WHT

SO-6005-WHT

SO-6012-WHT

SO-6003-WHT

Sell Sheet

SO-6003/SO-6005 SO-6012/SO-6020 SO-6030

METAL PEDAL BINS

Aesthetic and practical solution for general waste management

Available in Stainless Steel 18/0 and white epoxy.

Pedal mechanism made of 100 % metal components for a better durability

Smooth surfaces for easy maintenance.



Plastic liner allows for cleaner container and eases hygienic disposal of contents



Ergonomic handle for easy hygienic handling



Ideal for hotels bathrooms and away-from-home washrooms in general



Fire safe through automatic closing and fully protected pedal mechanism





Technical Sheet SO-6003

METAL PEDAL BIN - 3 L

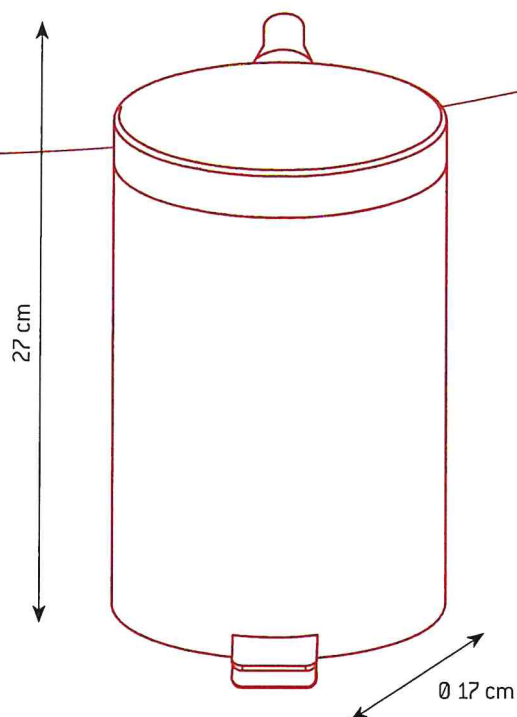

GIFT BOX SPECIFICATIONS

Product codes :

SO-6003-MSSTL
SO-6003-WHT

EAN codes :

-MSSTL : 4897020620051
-WHT : 4897020620044

Material :

-MSSTL : Stainless Steel 18/0
-WHT : Galvanised steel (epoxy)

Colours :

-MSSTL : Mirror Stainless Steel
-WHT : White

Capacity :

3 L

Product net weight :

0,78 kg/unit

Product dimensions :

(L) 17 x (W) 17 x (H) 27 cm

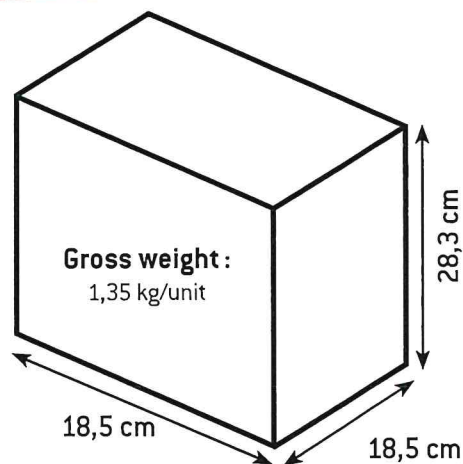

CARTON SPECIFICATIONS

