

Sefram

MW9520

CABLE LOCATOR



INSTRUCTION MANUAL

Index	Page
1. Introduction.....	1
2. Safety notes.....	2
3. Features.....	3-4
4. Specifications.....	5-6
5. Instrument layout.....	7-11
6. Operation.....	12-20
7. Maintenance.....	21-22

1. Introduction

Note

This cable locator has been designed and tested according to CE Safety Requirements for Electronic Measuring Apparatus, EN 61010-1 EN 61326-1 and other safety standards. Follow all warnings to ensure safe operation.

Warning

Read "Safety Notes"(next page) before using the cable locator.

2. Safety Notes

- Read the following safety information carefully before attempting to operate or service the cable locator.
- Use the cable locator only as specified in this manual, otherwise the protection provided by the cable locator may be impaired.
- Rated environmental conditions:
 - (1) Indoor use.
 - (2) Installation Category III 300V
 - (3) Pollution Degree 2.
 - (4) Altitude up to 2000 Meter.
 - (5) Relative Humidity 80% Max.
 - (6) Ambient Temperature 0~40°C.
- Observe the international electrical symbols listed below.

 Meter is protected throughout by double insulation or reinforced insulation.

 Warning ! Risk of electric shock.

 Caution ! Refer to this manual before using the meter.

 Earth (ground).

3.Features

Transmitter

- The MW9520 transmitter is a great tool for locating and identifying cables and individual conductors.
- Designed for locating unenergized cables and powered cables.
- Voltage measurement for cables :
ACV 12V~300V
DCV 12V~300V
- Signal Transmission
 - Transmission Power Level Selection
(includes 1, 2, 3)
 - Transmission Signal Code Selection
(includes F, E, H, d, L, C, O, A)
- Flashlight & Back Light function.
- The Silent Mode (Disable Button Beep).
- The Level Bar Display on the LCD Screen
(the transmission power level indication).
- The Action Wave Display on the LCD Screen
(when the signal is transmitted).
- Auto power off function.

Receiver

- The MW9520 receiver is designed to identify and trace wires or cables.
- Designed for locating unenergized cables and powered cables.
- Signal Detection (includes Level, Code, Value)
 - Automatic Mode
 - Manual Mode (There are 9 levels to select).
- U_{AC} Mode (AC Power Line Detection)
- Flashlight & Back Light function.
- The Silent Mode (Disable Button Beep & Frequency Tone)
- The Danger Symbol is to indicate the AC voltage on the Line.
- The Level Bar Display on the LCD Screen for the signal value & the U_{AC} power value.
- Auto power off function.

4. Specifications

Transmitter

Output signal frequency	125kHz
Voltage measurement range Accuracy	12~300V AC / DC $\pm(2\%rdg+2dgt)$
Display	LCD shows function and bargraph
Power source	1.5V (AAA) battery × 6
Fuse	690V/0.5A (6.3 × 32mm)
Operating temperature & humidity	0°C~40°C 80% R.H. Max.
Storage temperature & humidity	-10°C~50°C 80% R.H. Max.
Dimensions	247(L)×78(W)×45(D)mm
Weight(battery included)	Approx. 389g

Receiver

Detection depth	< 50cm
Display	LCD shows function and bargraph
Power source	1.5V (AAA) battery × 6
Operating temperature & humidity	0°C~40°C 80% R.H. Max.
Storage temperature & humidity	-10°C~50°C 80% R.H. Max.
Dimensions	188(L)×90(W)×47(D)mm
Weight(battery included)	Approx. 324g

- Safety Standard :
EN 61010-1 CAT III 300V
EN 61326-1
- Low battery indication:
"  " symbol appears and flashes on the LCD
- Accessories :
Instruction manual
Test leads
Alligator clip
Spike
Batteries
Carry case

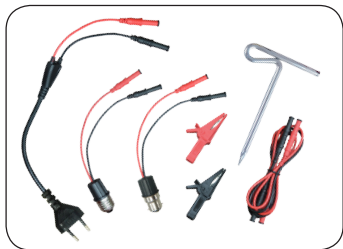

5. Instrument layout

Transmitter

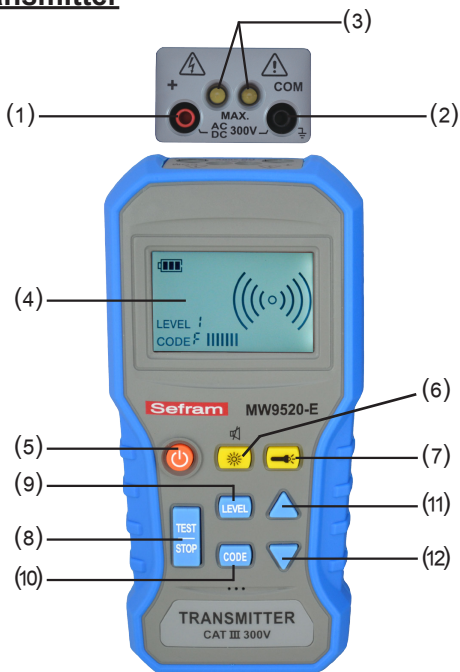

(1) "+" Terminal

(2) "COM" Terminal

(3) Flashlight

(4) LCD

(5) ON/OFF Button

(6) Backlight and Mute Button

(7) Flashlight Button

(8) TEST/STOP Button

(9) LEVEL Button

(10) CODE Button

(11) ▲ Button

(12) ▼ Button

(1) "+" Terminal

This is the positive terminal. Use the RED test lead to connect.

(2) "COM" Terminal

This is the ground terminal. Use the Black test lead to connect.

(3) Flashlight

(4) LCD

(5) ON/OFF Button

Press the ON/OFF button to turn on or turn off the transmitter.

(6) Backlight and Mute Button

Press it to turn on or turn off the LCD Backlight.
Press and hold it for more than 1 second to switch on or switch off the mute function.

(7) Flashlight Button

Press it to turn on or turn off the LED lights.

(8) TEST/STOP Button

Press it to send a transmission signal or stop sending the transmission signal.

(9) LEVEL Button

Press it to enter into the level selection mode, the "LEVEL" symbol will be flashing on the LCD.
There are 3 levels to select.

(10) CODE Button

Press and hold it for more than 1 second to enter into the code selection mode, the "CODE" symbol will be flashing on the LCD. There are 8 codes to select: F, E, H, d, L, C, O, A.

(11) ▲ Button

Press it to select the level upwards when the transmitter is in the level selection mode.

Press it to select the code upwards when the transmitter is in the code selection mode.

(12) ▼ Button

Press it to select the level downwards when the transmitter is in the level selection mode.

Press it to select the code downwards when the transmitter is in the code selection mode.

Receiver

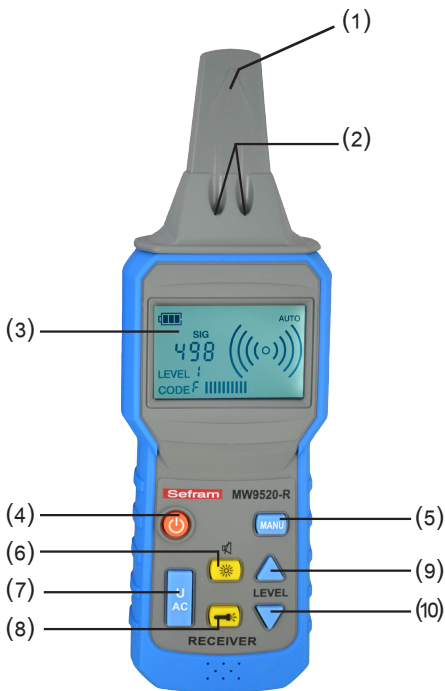

- | | |
|----------------------------|-------------------------------|
| (1) Sensor of the Receiver | (6) Backlight and Mute Button |
| (2) Flashlight | (7) UAC Button |
| (3) LCD | (8) Flashlight Button |
| (4) ON/OFF Button | (9) ▲ Button |
| (5) MANU Button | (10) ▼ Button |

(1) Sensor of the Receiver

Sensor of the receiver is used to detect the transmission signal.

(2) Flashlight

(3) LCD

(4) ON/OFF Button

Press the ON/OFF button to turn on or turn off the transmitter.

(5) MANU Button

Press it to enter into the manual detection mode, there are 8 sensitivity levels to select.

(6) Backlight and Mute Button

Press it to turn on or turn off the LCD Backlight.
Press and hold it for more than 1 second to switch on or switch off the mute function.

(7) UAC Button

Press it to switch to the non-contact voltage detection mode(UAC mode).

(8) Flashlight Button

Press it to turn on or turn off the LED lights.

(9) ▲ Button

Press it to select the sensitivity level upwards when the receiver is in the manual detection mode.

(10) ▼ Button

Press it to select the sensitivity level downwards when the receiver is in the manual detection mode.

6. Operation

The transmitter has 3 different modes:

- Test mode:
When the power is on, the transmitter is on the test mode. It can measure the AC or DC voltage of cable. When the user presses the TEST/STOP button, the transmitter will send a high frequency transmission signal down the cable. When the user presses the TEST/ STOP button again, the transmitter will stop sending the transmission signal.
- Level selection mode:
Press the LEVEL button to enter into the level selection mode of the transmitter, the LEVEL symbol will be flashing. User can press ▲ or ▼ button to select the level of the transmission signal (level: 1~3). The transmitter will return to the test mode by pressing the LEVEL button again.
- Code selection mode:
Press and hold the CODE button for more than 1 second to enter into the code selection mode of the transmitter, the CODE symbol will be flashing. User can press ▲ or ▼ button to select the code of the transmission signal (code: F, E, H, d, L, C, O, A). Once the code selection is done, the transmitter will return to the test mode by pressing the CODE button again.

The receiver has 3 different modes:

- Auto detection mode:
When the power is on, the receiver is on the auto detection mode to detect the high frequency transmission signal with the highest sensitivity. The speaker in the receiver will generate a tone(550Hz ~ 1.6kHz) and the bar-graph on the LCD indicates the signal strength.
- Manual detection mode:
Press the MANU button to enter into the manual detection mode. On the manual detection mode, user can select the signal sensitivity level (8 steps) by pressing ▲ or ▼ button. The receiver will return to the auto detection mode by pressing the MANU button.
- U_{AC} detection mode:
Press the U_{AC} button to enter into the non-contact voltage detection mode (U_{AC} mode) for non-contact voltage detection. The is for checking the AC power lines or the wall outlets.

Cable Locating:

(1) Single-pole application:

- (a) Connect the "+" (red) terminal to a single conductor, and connect the "COM" (black) terminal to earth. If there are other conductors in the same piping, then they have to be earthed at the same time. In this case, the MW9520-R can detect the NG position.

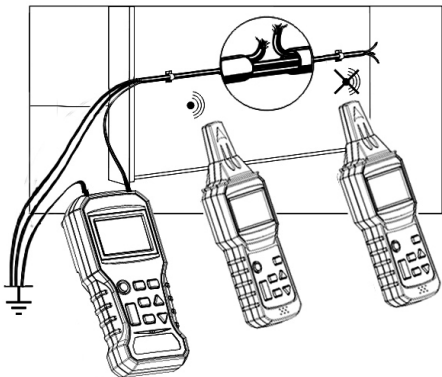

(b) Locating and tracing lines and outlets:

The circuit must not be live when it is detected, connect the "+" (red) terminal of MW9520-E to the phase and the other "COM" (black) terminal to the protection earth wire. If the cable supplied by the signals from the transmitter is near other conductors that are parallel to it (example: cable tray, channel, etc.) or is interlaced with or crosses them, the signal may then propagate in these cables and create spurious circuits then be detected.

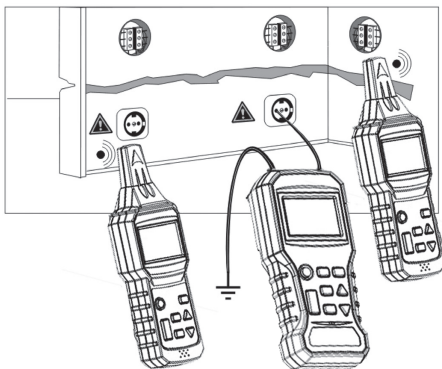

(2) Two-pole application:

(a) The live line connection:

Connect the "+" (red) terminal of MW9520-E to the phase line of the mains, and connect the "COM" (black) terminal to the neutral line of the mains. In this case, the MW9520-E can

measure the voltage of mains line and transmit the signal through the mains line, then the MW9520-R can trace the mains line and detect the power socket is locating on the same mains line or not.

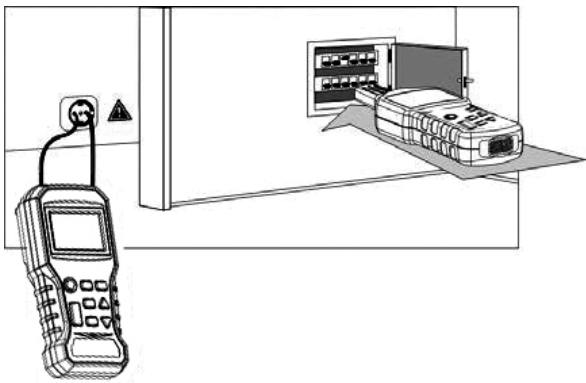
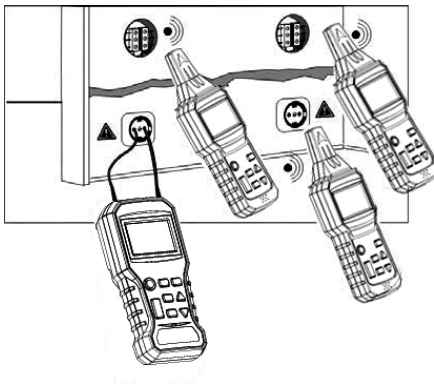

(b) The dead line connection:

Connect the both terminals of MW9520-E to the two ends of wires in the line, and connect the wires together on the other end of line. In another method, connect the both terminals of MW9520-E to the two ends of a single line. In this case, the MW9520-R can find out NG position or trace the signal line in the wall or floor.

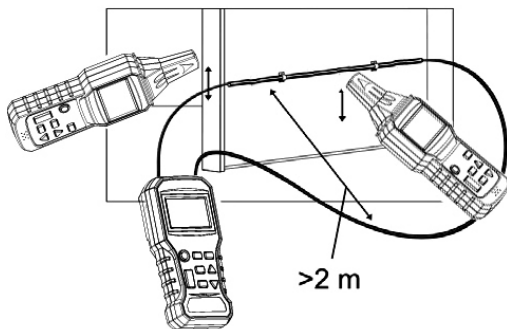
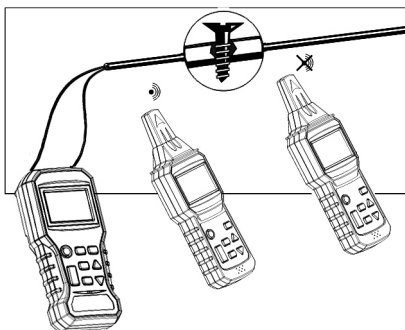

(3) Other application:

- (a) Detection of a metallic water supply and heating pipe:

The pipe must be conductive, and so metallic.
(for example galvanized steel)

The pipe must not be earthed, and there is a relatively high resistance between itself and ground. (otherwise, the detection distance is very short)

Connect "+" (red) terminal of MW9520-E to the pipe and "COM" (black) terminal of MW9520-E must be earthed.

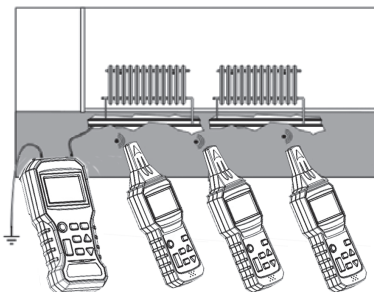
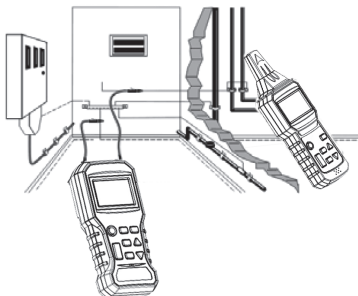

(b) Tracing an underground circuit:

The circuit to be measured must not be live.

Connect the MW9520-E as show in the figure.

The MW9520-E must be correctly earthed.

Select the automatic mode of MW9520-R to find and trace the circuit.

The distance between the earth wire and the circuit to be located must be as long as possible, otherwise the circuit cannot be located precisely.

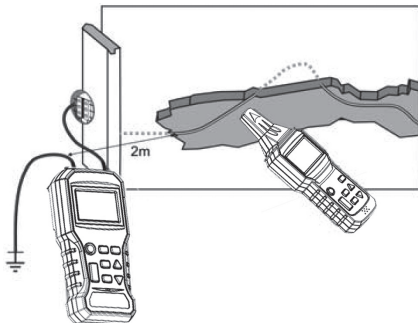

(c) Detection of faults in an in floor heating system:

The circuit measured must not be live, then

the right end of circuit is connected to the

transmitter that is sending "F" code signal, and

the left end of circuit is connected to the other

transmitter that is sending "C" code signal, and

the both transmitters must be earthed. When

the line is traced, the place at which the signal

received by the receiver falls off suddenly is the location of the break.

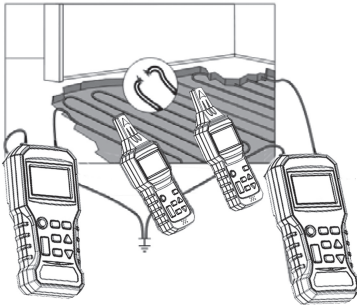

(d) Non-contact voltage detection:

The circuit must be connected to mains and live, and set the receiver to the UAC mode to detect. The AC signals detected by the receiver in the UAC mode indicated only whether the circuit is live or not. During the search for the ends of several supply lines, the lines must be connected separately, one by one. The number of bars is indication the strength of received signal emitted depend on the voltage in the circuit and the distance from the circuit.

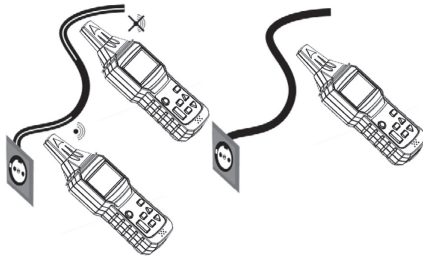

7. Maintenance

(1) Battery Replacement:

When the "  " symbol appears and flashes on the LCD, change new batteries as follows:

- Disconnect the test leads from the transmitter and turn off the power of the transmitter. Unscrew the battery cover and replace with new batteries(1.5V AAA × 6).

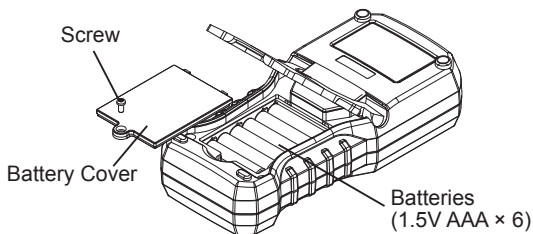

- Turn off the power of the receiver. Unscrew the battery cover and replace with new batteries(1.5V AAA × 6).

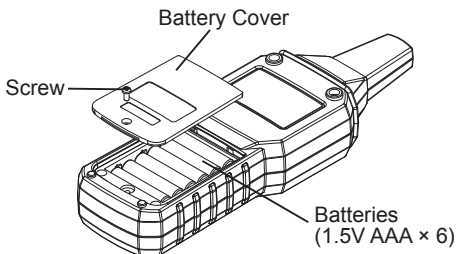

(2) Cleaning and storage:

WARNING

To avoid electrical shock or damage to the instrument, do not get water inside the case.

Periodically wipe the case with a damp cloth and detergent. Do not use abrasives or solvents.

If the instrument is not to be used for more than 60 days, please remove the batteries for storage.

SEFRAM
32 , rue Edouard MARTEL
BP 55
42009 – SAINT-ETIENNE Cedex 2
France

Tel : +33 (0)4 77 59 01 01
Fax :+33 (0)4 77 57 23 23
Web : www.sefram.fr
Mail : sales@sefram.fr