

# LM3526

*LM3526 Dual Port USB Power Switch and Over-Current Protection*



Literature Number: SNVS054D

# LM3526

## Dual Port USB Power Switch and Over-Current Protection

### General Description

The LM3526 provides Universal Serial Bus standard power switch and over-current protection for all host port applications. The dual port device is ideal for Notebook and desktop PC's that supply power to more than one port.

A 1 ms delay on the fault flag output prevents erroneous over-current reporting caused by in-rush currents during hot-plug events.

The dual stage thermal protection circuit in the LM3526 provides individual protection to each switch and the entire device. In a short-circuit/over-current event, the switch dissipating excessive heat is turned off, allowing the second switch to continue to function uninterrupted.

The LM3526 accepts an input voltage between 2.7V and 5.5V allowing use as a device-based in-rush current limiter for 3.3V USB peripherals, as well as Root and Self-Powered Hubs at 5.5V. The Enable inputs accept both 3.3V and 5.0V logic thresholds.

The small size, low  $R_{ON}$ , and 1 ms fault flag delay make the LM3526 a good choice for root hubs as well as per-port power control in embedded and stand-alone hubs.

### Features

- Compatible with USB1.1 and USB 2.0
- 1 ms fault flag delay filters Hot-Plug events
- Smooth turn-on eliminates in-rush induced voltage drop
- UL recognized component: REF# 205202
- 1A nominal short circuit output current protects PC power supplies
- Thermal shutdown protects device in direct short condition
- 500mA minimum continuous load current
- Small SO-8 package minimizes board space
- 2.7V to 5.5V input voltage range
- 140 mΩ Max. switch resistance
- 1  $\mu$ A Max. standby current
- 200  $\mu$ A Max. operating current
- Under-voltage lockout (UVLO)

### Applications

- Universal Serial Bus (USB) Root Hubs including Desktop and Notebook PC
- USB Monitor Hubs
- Other Self-Powered USB Hub Devices
- High Power USB Devices Requiring In-rush Limiting
- General Purpose High Side Switch Applications

### Typical Operating Circuit and Connection Diagram

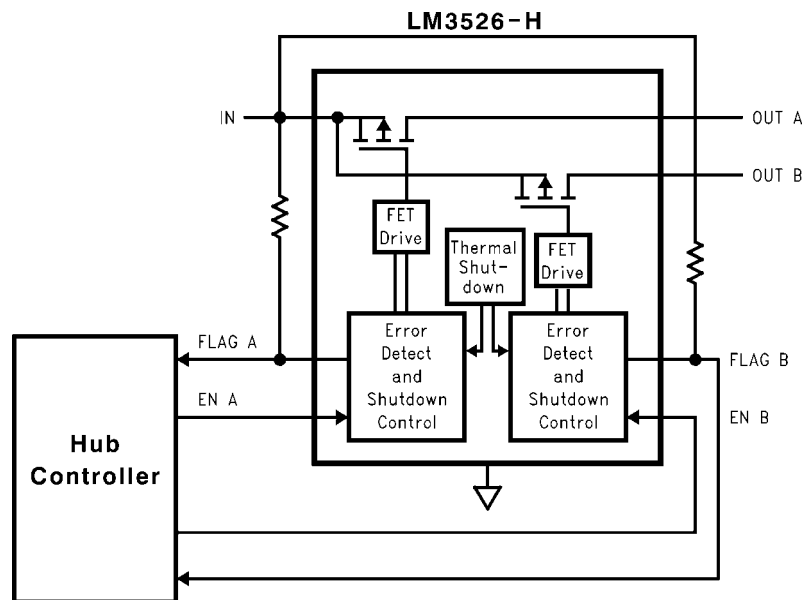

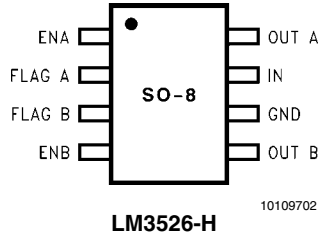

UL Recognized Component  
10109740

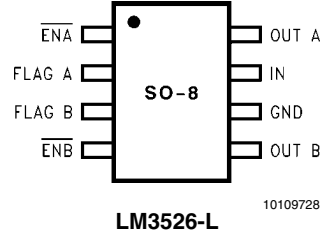

### Ordering Information

Part Number	Enable, Delivery Option	Package Type
LM3526M-H	Active High Enable, 95 units per rail	SO-8, NS Package Number M08A
LM3526M-L	Active Low Enable, 95 units per rail	
LM3526MX-H	Active High Enable, 2500 units per reel	
LM3526MX-L	Active Low Enable, 2500 units per reel	

## Absolute Maximum Ratings *(Note 1)*

If Military/Aerospace specified devices are required, please contact the National Semiconductor Sales Office/Distributors for availability and specifications.

Supply Voltage	-0.3V to 6V
Output Voltage	-0.3V to 6V
Voltage at All Other Pins	-0.3V to 5.5V
Power Dissipation ( $T_A = 25^\circ\text{C}$ )	700 mW
<i>(Note 2)</i>	
$T_{JMAX}$ <i>(Note 2)</i>	150°C

## Operating Ratings

Supply Voltage Range	2.7V to 5.5V
Operating Ambient Range	-40°C to 85°C
Operating Junction Temperature Range	-40°C to 125°C
Storage Temperature Range	-65°C to +150°C
Lead Temperature (Soldering, 5 seconds)	260°C
ESD Rating <i>(Note 3)</i>	2kV
ESD Rating Output Only	8kV

## DC Electrical Characteristics

Limits in standard typeface are for  $T_J = 25^\circ\text{C}$ , and limits in **boldface** type apply over the full operating temperature range. Unless otherwise specified:  $V_{IN} = 5.0\text{V}$ ,  $V_{EN} = 0\text{V}$  (LM3526-L) or  $V_{EN} = V_{IN}$  (LM3526-H).

Symbol	Parameter	Conditions	Min	Typ	Max	Units
$R_{ON}$	On Resistance	$V_{IN} = 5\text{V}$ , $I_{OUT} = 500\text{mA}$ , each switch		100	140	m $\Omega$
		$V_{IN} = 2.7\text{V}$ , $I_{OUT} = 500\text{mA}$ , each switch		110	180	
$I_{OUT}$	OUT pins continuous output current	Each Output	<b>0.5</b>			A
$I_{SC}$	Short Circuit Output Current	Each Output (enable into Load) <i>(Note 4)</i>	0.5	1.2	1.9	A
		$V_{OUT} = 4.0\text{V}$ $V_{OUT} = 0.1\text{V}$		1	1.5	
$OC_{THRESH}$	Over-current Threshold			2.2	3.2	A
$I_{LEAK}$	OUT pins Output Leakage Current	$V_{EN} = V_{IN}$ (LM3526-L) $V_{EN} = 0\text{V}$ (LM3526-H)		0.01	10	$\mu\text{A}$
$R_{FO}$	FLAG Output Resistance	$I_{FO} = 10\text{ mA}$ , $V_{IN} = 5.0\text{V}$		10	<b>25</b>	$\Omega$
		$I_{FO} = 10\text{ mA}$ , $V_{IN} = 3.3\text{V}$		11	<b>35</b>	
		$I_{FO} = 10\text{ mA}$ , $V_{IN} = 2.7\text{V}$		12	<b>40</b>	
$I_{EN}$	$\overline{EN}/EN$ Leakage Current	$V_{EN}/V_{EN} = 0\text{V}$ or $V_{EN}/V_{EN} = V_{IN}$	-0.5		0.5	$\mu\text{A}$
$V_{IH}$	$\overline{EN}/EN$ Input Logic High	<i>(Note 5)</i>	<b>2.4</b>	1.9		V
$V_{IL}$	$\overline{EN}/EN$ Input Logic Low	<i>(Note 5)</i>		1.7	<b>0.8</b>	V
$V_{UVLO}$	Under-Voltage Lockout Threshold			1.8		V
$I_{DDOFF}$	Supply Current	Switch-Off		0.2	1	$\mu\text{A}$
		-40°C $\leq T_J \leq$ 85°C			<b>2</b>	
$I_{DDON}$	Supply Current	Switch-On		115	200	$\mu\text{A}$
$Th_{SD}$	Over-temperature Shutdown Threshold	$T_J$ Increasing, with no shorted output		150		°C
		$T_J$ Increasing, with shorted output (s)		145		
		$T_J$ Decreasing <i>(Note 4)</i>		135		
$I_{FH}$	Error Flag Leakage Current	$V_{flag} = 5\text{V}$		0.01	1	$\mu\text{A}$

**Note 1:** Absolute Maximum Ratings indicate limits beyond which damage to the device may occur. Electrical specifications do not apply when operating the device beyond its rated operating conditions.

**Note 2:** The maximum power dissipation must be derated at elevated temperatures and is dictated by  $T_{JMAX}$  (Maximum junction temperature),  $\theta_{JA}$  (junction to ambient thermal resistance), and  $T_A$  (ambient temperature). The maximum allowable power dissipation at any temperature is  $P_{DMAX} = (T_{JMAX} - T_A)/\theta_{JA}$  or the number given in the Absolute Maximum Ratings, whichever is lower.  $\theta_{JA} = 150^\circ\text{C/W}$ .

**Note 3:** The human body model is a 100 pF capacitor discharged through a 1.5 k $\Omega$  resistor into each pin. Enable pin ESD threshold is 1.7kV.

**Note 4:** Thermal Shutdown will protect the device from permanent damage.

**Note 5:** For LM3526-L, OFF is  $\overline{EN} \geq 2.4\text{V}$  and ON is  $\overline{EN} \leq 0.8\text{V}$ . For LM3526-H, OFF is  $EN \leq 0.8\text{V}$  and ON is  $EN \geq 2.4\text{V}$ .

## AC Electrical Characteristics

Limits in standard typeface are for  $T_J = 25^\circ\text{C}$ , and limits in **boldface** type apply over the full operating temperature range. Unless otherwise specified:  $V_{IN} = 5.0\text{V}$ .

Symbol	Parameter	Conditions	Min	Typ	Max	Units
$t_r$	OUT Rise Time	$R_L = 10\Omega$		100		$\mu\text{s}$
$t_f$	OUT Fall Time	$R_L = 10\Omega$		5		$\mu\text{s}$
$t_{ON}$	Turn on Delay, $\overline{\text{EN}}$ to OUT	$R_L = 10\Omega$		150		$\mu\text{s}$
$t_{OFF}$	Turn off Delay, $\overline{\text{EN}}$ to OUT	$R_L = 10\Omega$		5		$\mu\text{s}$
$t_{OC}$	Over Current Flag Delay	$R_L = 0$		1		ms

## Pin Descriptions

Pin Number	Pin Name	Pin Function
1, 4	$\overline{\text{ENA}}$ , $\overline{\text{ENB}}$ (LM3526-L) $\text{ENA}$ , $\text{ENB}$ (LM3526-H)	Enable (Input): Logic-compatible enable inputs.
2, 3	FLAG A FLAG B	Fault Flag (Output): Active-low, open-drain outputs. Indicates overcurrent, UVLO or thermal shutdown. *See application section for more information.
6	GND	Ground
7	IN	Supply Input: This pin is the input to the power switch and the supply voltage for the IC.
8, 5	OUT A OUT B	Switch Output: These pins are the outputs of the high side switch.

## Typical Application Circuit

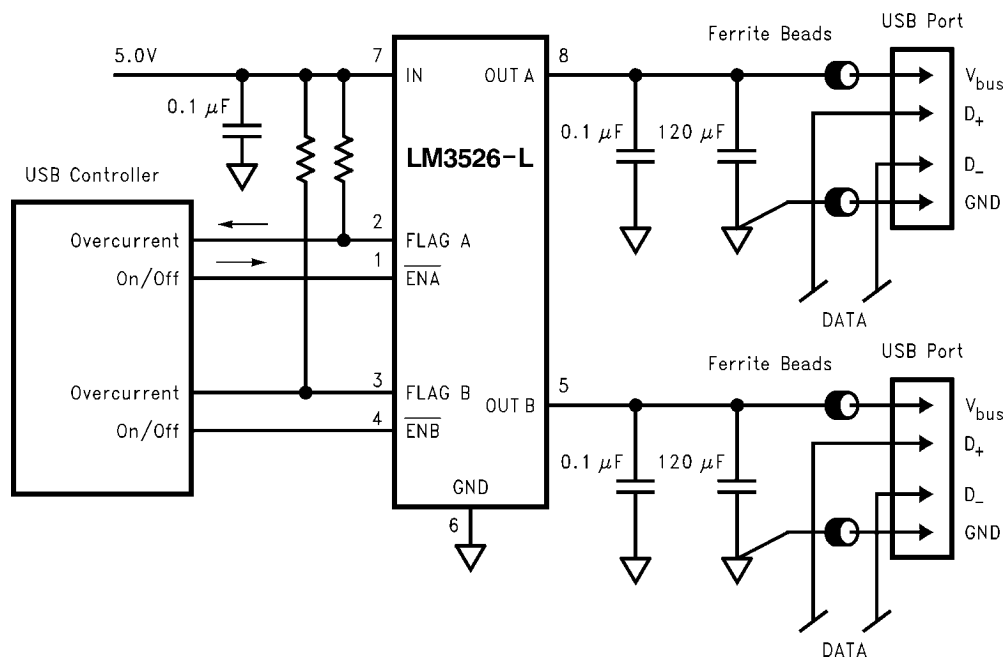

10109703

# Typical Performance Characteristics

$V_{IN} = 5.0V$ ,  $I_L = 500\text{ mA}$ ,  $T_A = 25^\circ\text{C}$  unless otherwise specified.

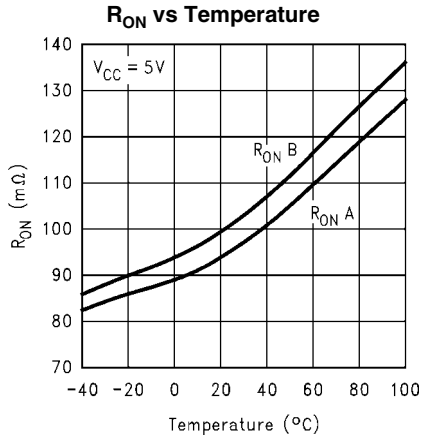

10109704

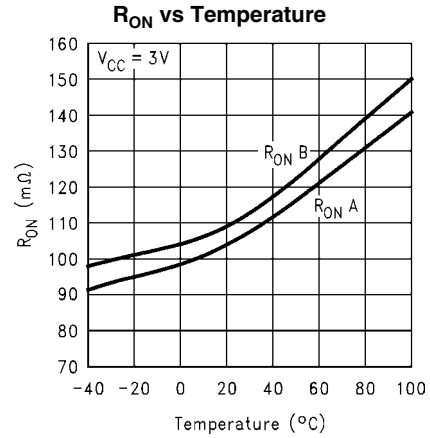

10109705

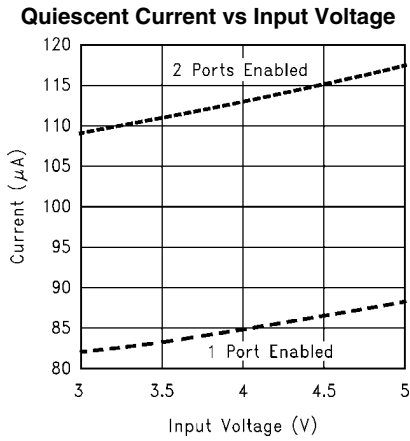

10109706

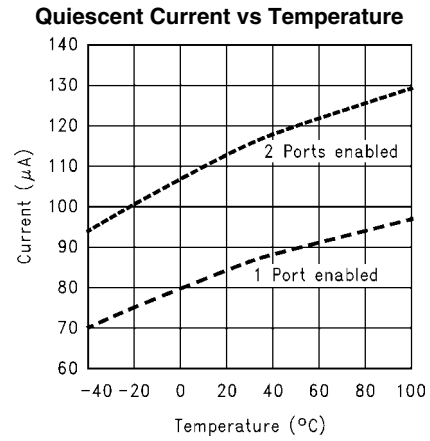

10109707

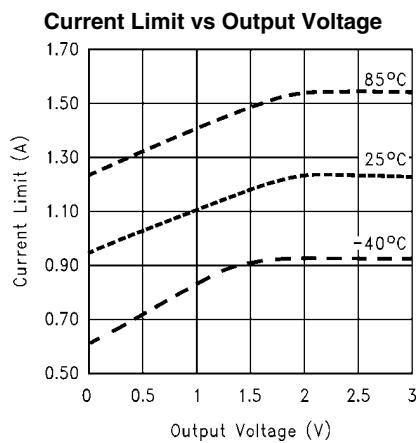

10109708

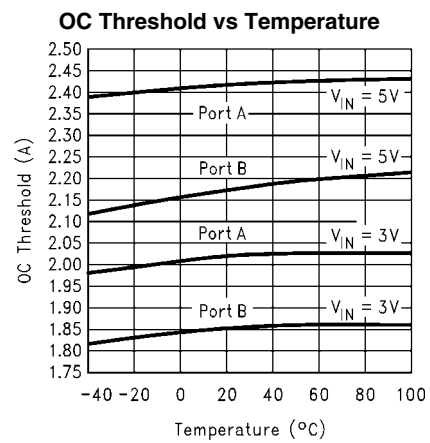

10109709

**Fault Flag Delay vs Temperature**

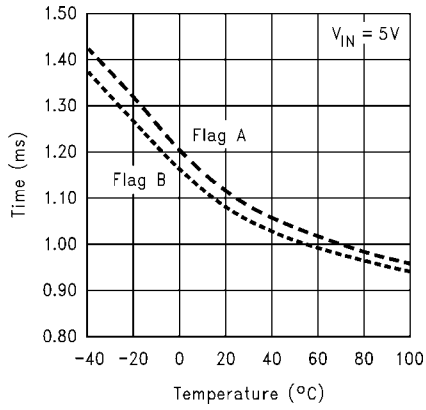

10109735

**Fault Flag Delay vs Temperature**

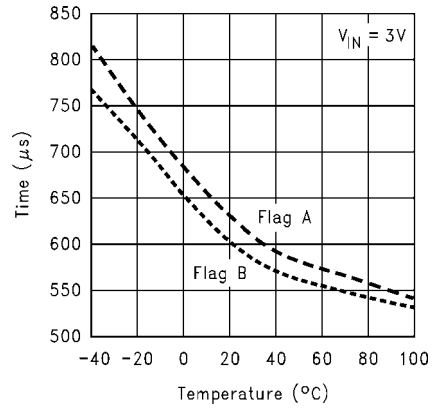

10109736

**Under Voltage Lockout (UVLO)**

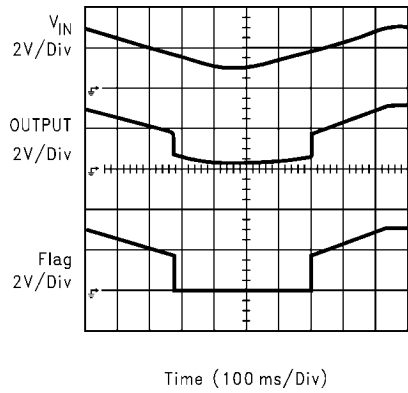

10109734

**Under Voltage Lockout Threshold vs Temperature**

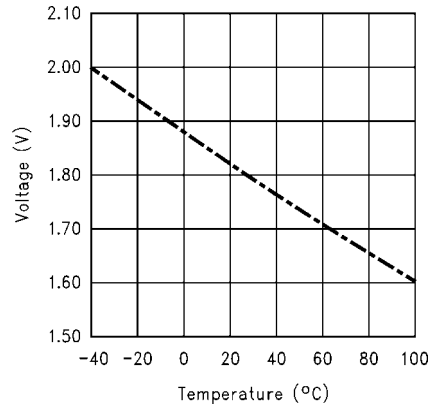

10109737

**Over Current/Current Limit Response\***

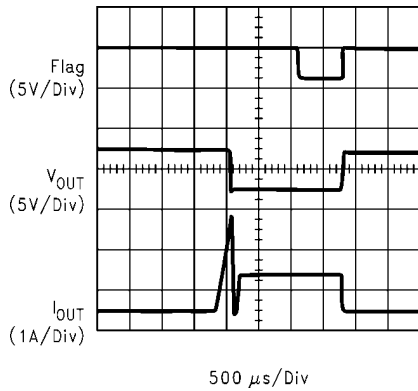

10109710

\* Output is shorted to Ground through a 100 mΩ resistor

**Short Circuit Response with Thermal Cycling\***

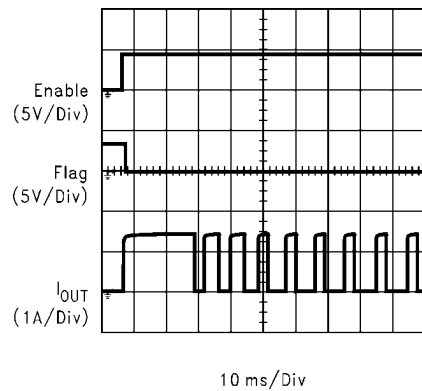

10109711

**Turn-ON/OFF Response with  
47Ω/10μF Load**

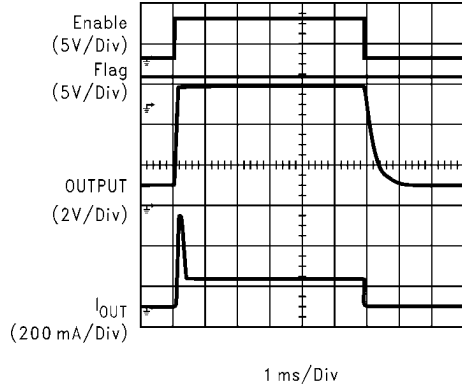

10109712

**Turn-ON/OFF Response with  
47Ω/150μF Load**

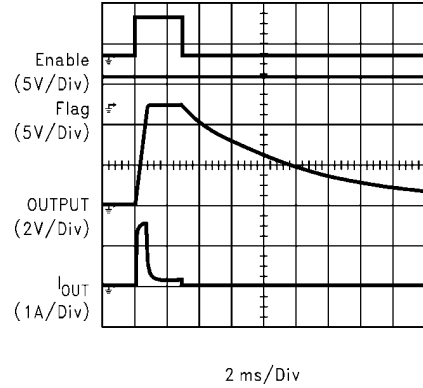

10109713

**Thermal Shutdown Response  
(Port A output shorted\*)**

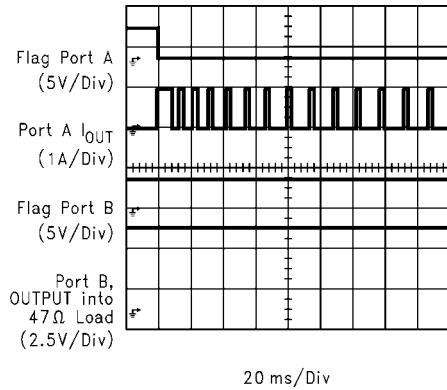

10109714

**Thermal Shutdown Response (See Notes)**

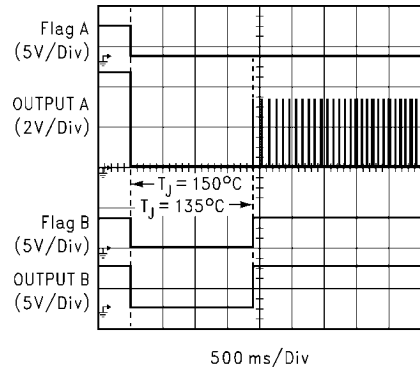

10109729

\* Port A is shorted to GND through a 100 mΩ resistor

**Enable into a short**

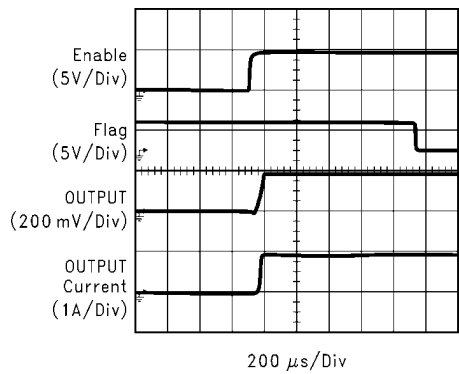

10109730



## Functional Description

The LM3526-H and LM3526-L are high side P-Channel switches with active-high and active-low enable inputs, respectively. Fault conditions turn-off and inhibit turn-on of the output transistor and activate the open-drain error flag transistor sinking current to the ground.

### INPUT AND OUTPUT

IN (Input) is the power supply connection to the control circuitry and the source of the output MOSFET.

OUT (Output) is the connection to the drain of the output MOSFET. In a typical application circuit, current flows through the switch from IN to OUT towards the load.

If  $V_{OUT}$  is greater than  $V_{IN}$  when the switch is enabled, current will flow from OUT to IN since the MOSFET is bidirectional.

### THERMAL SHUTDOWN

The LM3526 is internally protected against excessive power dissipation by a two-stage thermal protection circuit. If the device temperature rises to approximately 145°C, the thermal shutdown circuitry turns off any switch that is current limited. Non-overloaded switches continue to function normally. If the die temperature rises above 150°C, both switches are turned off and both fault flag outputs are activated. Hysteresis ensures that a switch turned off by thermal shutdown will not be turned on again until the die temperature is reduced to 135°C. Shorted switches will continue to cycle off and on, due to the rising and falling die temperature, until the short is removed.

### UNDERVOLTAGE LOCKOUT

UVLO prevents the MOSFET switch from turning on until input voltage exceeds 1.8V (typical).

If input voltage drops below 1.8V (typical), UVLO shuts off the MOSFET switch and signals the fault flag. UVLO functions only when device is enabled.

### CURRENT LIMIT

The current limit circuit is designed to protect the system supply, the MOSFET switches and the load from damage caused by excessive currents. The current limit threshold is set internally to allow a minimum of 500 mA through the MOSFET but limits the output current to approximately 1.0A typical.

### FAULT FLAG

The fault flag is an open-drain output capable of sinking 10 mA load current to typically 100 mV above ground.

A parasitic diode exists between the flag pins and  $V_{IN}$  pin. Pulling the flag pins to voltages higher than  $V_{IN}$  will forward bias this diode and will cause an increase in supply current. This diode will also clamp the voltage on the flag pins to a diode drop above  $V_{IN}$ .

The fault flag is active (pulled low) when any of the following conditions are present: under-voltage, current limit, or thermal shutdown.

A 1ms (typ.) delay in reporting the fault condition prevents erroneous fault flags and eliminates the need for an external RC delay network.

## Application Information

### FILTERING

The USB specification indicates that “no less than 120  $\mu$ F tantalum capacitors” must be used on the output of each downstream port. This bulk capacitance provides the short-

term transient current needed during a hot plug-in. Current surges caused by the input capacitance of the downstream device could generate undesirable EMI signals. Ferrite beads in series with all power and ground lines are recommended to eliminate or significantly reduce EMI.

In selecting a ferrite bead, the DC resistance of the wire used must be kept to a minimum to reduce the voltage drop.

A 0.01  $\mu$ F ceramic capacitor is recommended on each port directly between the  $V_{BUS}$  and ground pins to prevent EMI damage to other components during the hot-detachment.

Adequate capacitance must be connected to the input of the device to limit the input voltage drop during a hot-plug event to less than 330 mV. For a few tens of  $\mu$ s, the host must supply the in-rush current to the peripheral, charging its bulk capacitance to  $V_{BUS}$ . This current is initially supplied by the input capacitor. A 33  $\mu$ F 16V tantalum capacitor is recommended.

In choosing the capacitors, special attention must be paid to the Effective Series Resistance, ESR, of the capacitors to minimize the IR drop across the capacitor's ESR.

### SOFT START

To eliminate the upstream voltage droop caused by the high in-rush current drawn by the output capacitors, the maximum in-rush current is internally limited to 1.5A.

### TRANSIENT OVER-CURRENT DELAY

High transient current is also generated when the switch is enabled and large values of capacitance at the output have to be rapidly charged. The in-rush currents created could exceed the short circuit current limit threshold of the device forcing it into the current limit mode. The capacitor is charged with the maximum available short circuit current set by the LM3526. The duration of the in-rush current depends on the size of the output capacitance and load current. Since this is not a valid fault condition, the LM3526 delays the generation of the fault flag for 1 ms. If the condition persists due to other causes such as a short, a fault flag is generated after a 1 ms delay has elapsed.

The LM3526's 1 ms delay in issuing the fault flag is adequate for most applications. If longer delays are required, an RC filter as shown in *Figure 1* may be used.

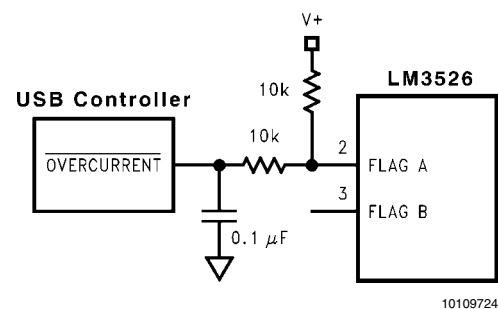

FIGURE 1.

### PCB LAYOUT CONSIDERATIONS

In order to meet the USB requirements for voltage drop, droop and EMI, each component used in this circuit must be evaluated for its contribution to the circuit performance. The PCB layout rules and guidelines must be followed.

- Place the switch as close to the USB connector as possible. Keep all  $V_{BUS}$  traces as short as possible and use at least 50-mil, 1 ounce copper for all  $V_{BUS}$  traces. Solder plating the traces will reduce the trace resistance.

- Avoid vias as much as possible. If vias are used, use multiple vias in parallel and/or make them as large as possible.
- Place the output capacitor and ferrite beads as close to the USB connector as possible.
- If ferrite beads are used, use wires with minimum resistance and large solder pads to minimize connection resistance.

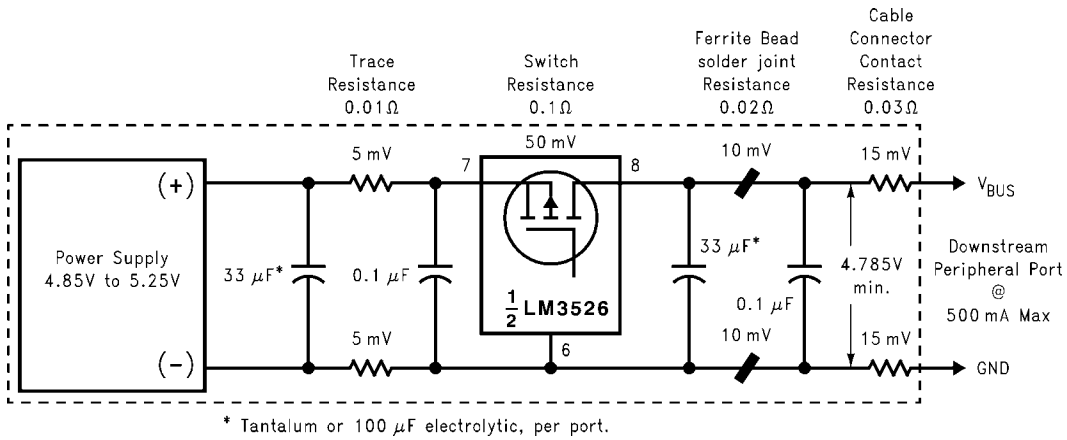

10109723

FIGURE 2. Self-Powered Hub Per-Port Voltage Drop

# Typical Applications

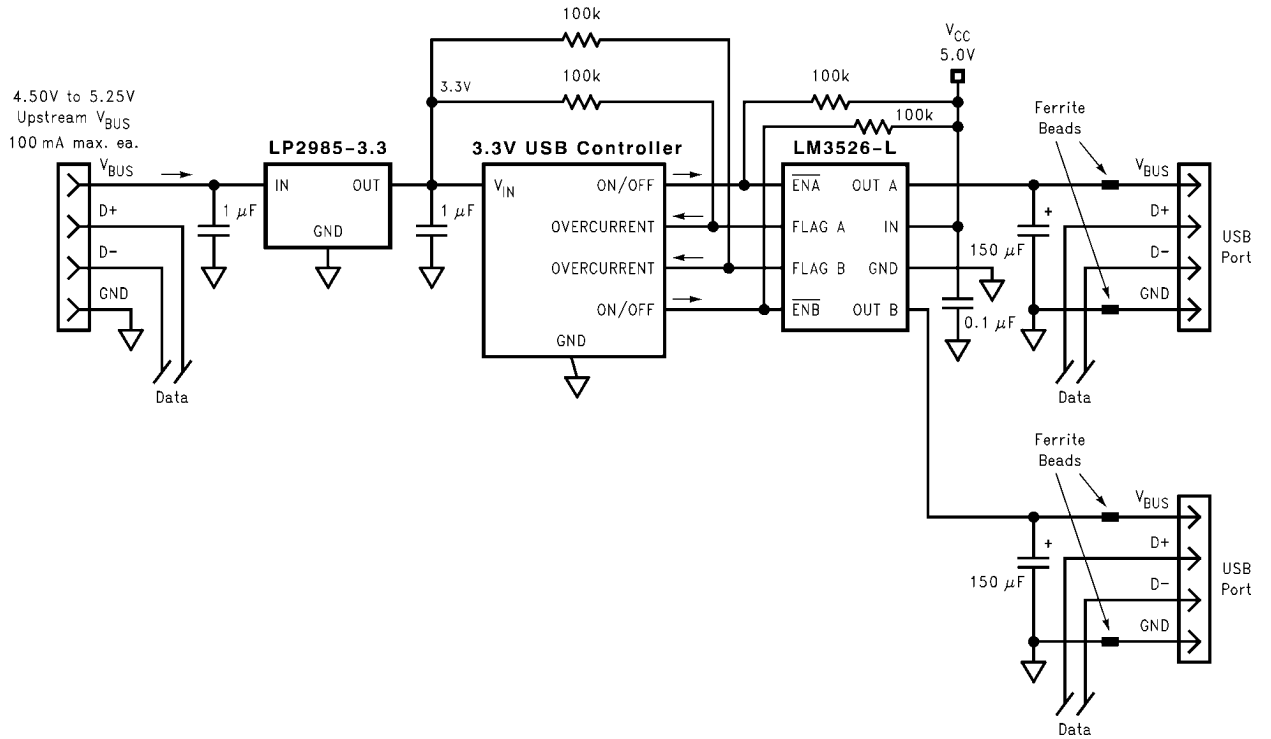

10109725

FIGURE 3. Dual-Port USB Self-Powered Hub

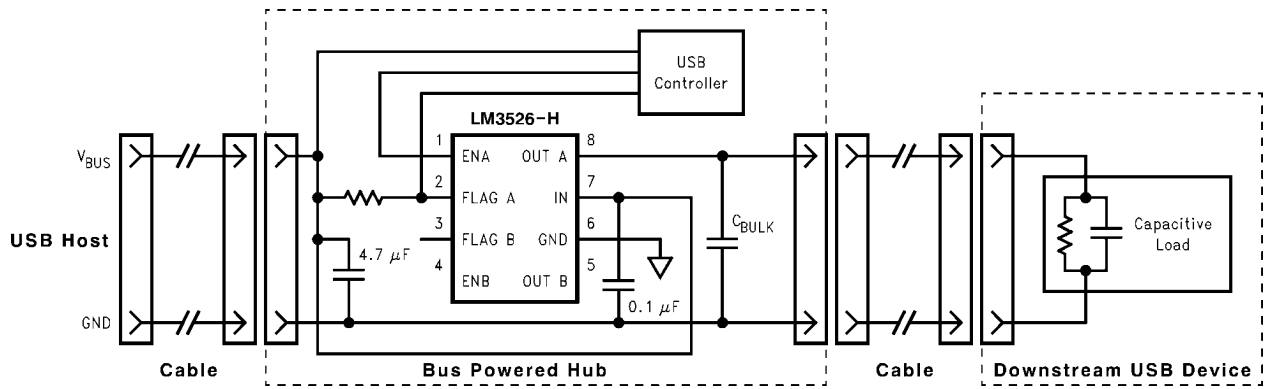

10109726

FIGURE 4. Soft-Start Application (Single port shown)

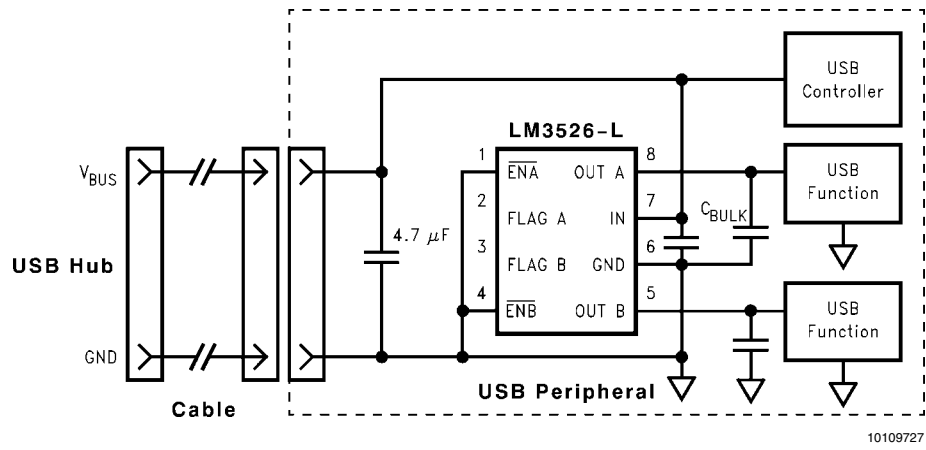
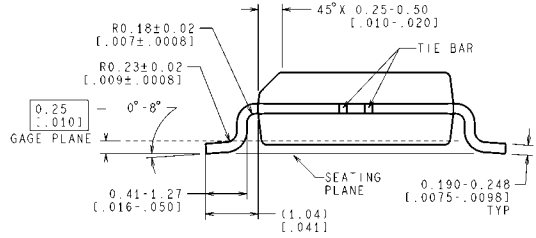
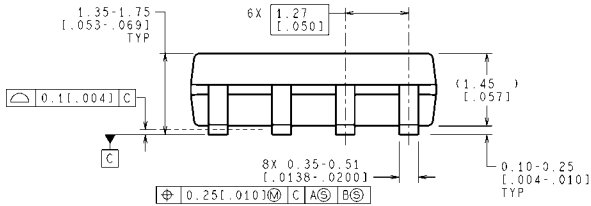
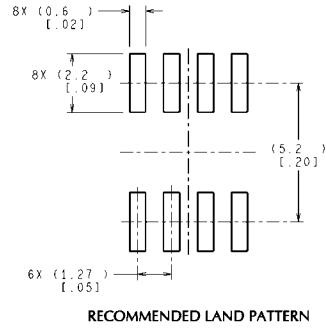
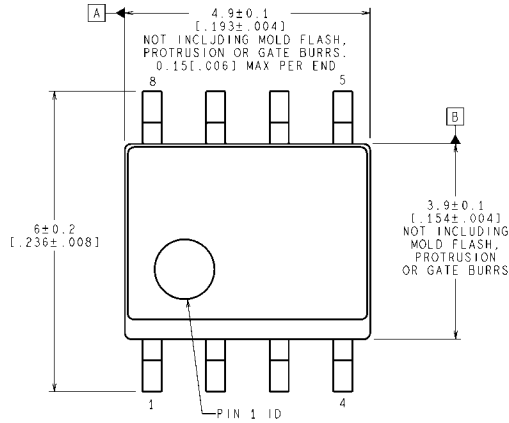

FIGURE 5. In-rush Current-limit Application

**Physical Dimensions** inches (millimeters) unless otherwise noted



CONTROLLING DIMENSION IS MILLIMETER  
VALUES IN [ ] ARE INCHES  
DIMENSIONS IN ( ) FOR REFERENCE ONLY

**See Order Information Table  
NS Package Number M08A**

M08A (Rev M)

# Notes

LM3526

## Notes

For more National Semiconductor product information and proven design tools, visit the following Web sites at:  
[www.national.com](http://www.national.com)

Products		Design Support	
Amplifiers	<a href="http://www.national.com/amplifiers">www.national.com/amplifiers</a>	WEBENCH® Tools	<a href="http://www.national.com/webench">www.national.com/webench</a>
Audio	<a href="http://www.national.com/audio">www.national.com/audio</a>	App Notes	<a href="http://www.national.com/appnotes">www.national.com/appnotes</a>
Clock and Timing	<a href="http://www.national.com/timing">www.national.com/timing</a>	Reference Designs	<a href="http://www.national.com/refdesigns">www.national.com/refdesigns</a>
Data Converters	<a href="http://www.national.com/adc">www.national.com/adc</a>	Samples	<a href="http://www.national.com/samples">www.national.com/samples</a>
Interface	<a href="http://www.national.com/interface">www.national.com/interface</a>	Eval Boards	<a href="http://www.national.com/evalboards">www.national.com/evalboards</a>
LVDS	<a href="http://www.national.com/lvds">www.national.com/lvds</a>	Packaging	<a href="http://www.national.com/packaging">www.national.com/packaging</a>
Power Management	<a href="http://www.national.com/power">www.national.com/power</a>	Green Compliance	<a href="http://www.national.com/quality/green">www.national.com/quality/green</a>
Switching Regulators	<a href="http://www.national.com/switchers">www.national.com/switchers</a>	Distributors	<a href="http://www.national.com/contacts">www.national.com/contacts</a>
LDOs	<a href="http://www.national.com/ldo">www.national.com/ldo</a>	Quality and Reliability	<a href="http://www.national.com/quality">www.national.com/quality</a>
LED Lighting	<a href="http://www.national.com/led">www.national.com/led</a>	Feedback/Support	<a href="http://www.national.com/feedback">www.national.com/feedback</a>
Voltage References	<a href="http://www.national.com/vref">www.national.com/vref</a>	Design Made Easy	<a href="http://www.national.com/easy">www.national.com/easy</a>
PowerWise® Solutions	<a href="http://www.national.com/powerwise">www.national.com/powerwise</a>	Applications & Markets	<a href="http://www.national.com/solutions">www.national.com/solutions</a>
Serial Digital Interface (SDI)	<a href="http://www.national.com/sdi">www.national.com/sdi</a>	Mil/Aero	<a href="http://www.national.com/milaero">www.national.com/milaero</a>
Temperature Sensors	<a href="http://www.national.com/tempensors">www.national.com/tempensors</a>	SolarMagic™	<a href="http://www.national.com/solarmagic">www.national.com/solarmagic</a>
PLL/VCO	<a href="http://www.national.com/wireless">www.national.com/wireless</a>	PowerWise® Design University	<a href="http://www.national.com/training">www.national.com/training</a>

THE CONTENTS OF THIS DOCUMENT ARE PROVIDED IN CONNECTION WITH NATIONAL SEMICONDUCTOR CORPORATION ("NATIONAL") PRODUCTS. NATIONAL MAKES NO REPRESENTATIONS OR WARRANTIES WITH RESPECT TO THE ACCURACY OR COMPLETENESS OF THE CONTENTS OF THIS PUBLICATION AND RESERVES THE RIGHT TO MAKE CHANGES TO SPECIFICATIONS AND PRODUCT DESCRIPTIONS AT ANY TIME WITHOUT NOTICE. NO LICENSE, WHETHER EXPRESS, IMPLIED, ARISING BY ESTOPPEL OR OTHERWISE, TO ANY INTELLECTUAL PROPERTY RIGHTS IS GRANTED BY THIS DOCUMENT.

TESTING AND OTHER QUALITY CONTROLS ARE USED TO THE EXTENT NATIONAL DEEMS NECESSARY TO SUPPORT NATIONAL'S PRODUCT WARRANTY. EXCEPT WHERE MANDATED BY GOVERNMENT REQUIREMENTS, TESTING OF ALL PARAMETERS OF EACH PRODUCT IS NOT NECESSARILY PERFORMED. NATIONAL ASSUMES NO LIABILITY FOR APPLICATIONS ASSISTANCE OR BUYER PRODUCT DESIGN. BUYERS ARE RESPONSIBLE FOR THEIR PRODUCTS AND APPLICATIONS USING NATIONAL COMPONENTS. PRIOR TO USING OR DISTRIBUTING ANY PRODUCTS THAT INCLUDE NATIONAL COMPONENTS, BUYERS SHOULD PROVIDE ADEQUATE DESIGN, TESTING AND OPERATING SAFEGUARDS.

EXCEPT AS PROVIDED IN NATIONAL'S TERMS AND CONDITIONS OF SALE FOR SUCH PRODUCTS, NATIONAL ASSUMES NO LIABILITY WHATSOEVER, AND NATIONAL DISCLAIMS ANY EXPRESS OR IMPLIED WARRANTY RELATING TO THE SALE AND/OR USE OF NATIONAL PRODUCTS INCLUDING LIABILITY OR WARRANTIES RELATING TO FITNESS FOR A PARTICULAR PURPOSE, MERCHANTABILITY, OR INFRINGEMENT OF ANY PATENT, COPYRIGHT OR OTHER INTELLECTUAL PROPERTY RIGHT.

### LIFE SUPPORT POLICY

**NATIONAL'S PRODUCTS ARE NOT AUTHORIZED FOR USE AS CRITICAL COMPONENTS IN LIFE SUPPORT DEVICES OR SYSTEMS WITHOUT THE EXPRESS PRIOR WRITTEN APPROVAL OF THE CHIEF EXECUTIVE OFFICER AND GENERAL COUNSEL OF NATIONAL SEMICONDUCTOR CORPORATION.** As used herein:

Life support devices or systems are devices which (a) are intended for surgical implant into the body, or (b) support or sustain life and whose failure to perform when properly used in accordance with instructions for use provided in the labeling can be reasonably expected to result in a significant injury to the user. A critical component is any component in a life support device or system whose failure to perform can be reasonably expected to cause the failure of the life support device or system or to affect its safety or effectiveness.

National Semiconductor and the National Semiconductor logo are registered trademarks of National Semiconductor Corporation. All other brand or product names may be trademarks or registered trademarks of their respective holders.

Copyright© 2011 National Semiconductor Corporation

For the most current product information visit us at [www.national.com](http://www.national.com)



**National Semiconductor  
Americas Technical  
Support Center**  
Email: [support@nsc.com](mailto:support@nsc.com)  
Tel: 1-800-272-9959

**National Semiconductor Europe  
Technical Support Center**  
Email: [europe.support@nsc.com](mailto:europe.support@nsc.com)

**National Semiconductor Asia  
Pacific Technical Support Center**  
Email: [ap.support@nsc.com](mailto:ap.support@nsc.com)

**National Semiconductor Japan  
Technical Support Center**  
Email: [jpn.feedback@nsc.com](mailto:jpn.feedback@nsc.com)

## IMPORTANT NOTICE

Texas Instruments Incorporated and its subsidiaries (TI) reserve the right to make corrections, modifications, enhancements, improvements, and other changes to its products and services at any time and to discontinue any product or service without notice. Customers should obtain the latest relevant information before placing orders and should verify that such information is current and complete. All products are sold subject to TI's terms and conditions of sale supplied at the time of order acknowledgment.

TI warrants performance of its hardware products to the specifications applicable at the time of sale in accordance with TI's standard warranty. Testing and other quality control techniques are used to the extent TI deems necessary to support this warranty. Except where mandated by government requirements, testing of all parameters of each product is not necessarily performed.

TI assumes no liability for applications assistance or customer product design. Customers are responsible for their products and applications using TI components. To minimize the risks associated with customer products and applications, customers should provide adequate design and operating safeguards.

TI does not warrant or represent that any license, either express or implied, is granted under any TI patent right, copyright, mask work right, or other TI intellectual property right relating to any combination, machine, or process in which TI products or services are used. Information published by TI regarding third-party products or services does not constitute a license from TI to use such products or services or a warranty or endorsement thereof. Use of such information may require a license from a third party under the patents or other intellectual property of the third party, or a license from TI under the patents or other intellectual property of TI.

Reproduction of TI information in TI data books or data sheets is permissible only if reproduction is without alteration and is accompanied by all associated warranties, conditions, limitations, and notices. Reproduction of this information with alteration is an unfair and deceptive business practice. TI is not responsible or liable for such altered documentation. Information of third parties may be subject to additional restrictions.

Resale of TI products or services with statements different from or beyond the parameters stated by TI for that product or service voids all express and any implied warranties for the associated TI product or service and is an unfair and deceptive business practice. TI is not responsible or liable for any such statements.

TI products are not authorized for use in safety-critical applications (such as life support) where a failure of the TI product would reasonably be expected to cause severe personal injury or death, unless officers of the parties have executed an agreement specifically governing such use. Buyers represent that they have all necessary expertise in the safety and regulatory ramifications of their applications, and acknowledge and agree that they are solely responsible for all legal, regulatory and safety-related requirements concerning their products and any use of TI products in such safety-critical applications, notwithstanding any applications-related information or support that may be provided by TI. Further, Buyers must fully indemnify TI and its representatives against any damages arising out of the use of TI products in such safety-critical applications.

TI products are neither designed nor intended for use in military/aerospace applications or environments unless the TI products are specifically designated by TI as military-grade or "enhanced plastic." Only products designated by TI as military-grade meet military specifications. Buyers acknowledge and agree that any such use of TI products which TI has not designated as military-grade is solely at the Buyer's risk, and that they are solely responsible for compliance with all legal and regulatory requirements in connection with such use.

TI products are neither designed nor intended for use in automotive applications or environments unless the specific TI products are designated by TI as compliant with ISO/TS 16949 requirements. Buyers acknowledge and agree that, if they use any non-designated products in automotive applications, TI will not be responsible for any failure to meet such requirements.

Following are URLs where you can obtain information on other Texas Instruments products and application solutions:

### Products

Audio	<a href="http://www.ti.com/audio">www.ti.com/audio</a>
Amplifiers	<a href="http://amplifier.ti.com">amplifier.ti.com</a>
Data Converters	<a href="http://dataconverter.ti.com">dataconverter.ti.com</a>
DLP® Products	<a href="http://www.dlp.com">www.dlp.com</a>
DSP	<a href="http://dsp.ti.com">dsp.ti.com</a>
Clocks and Timers	<a href="http://www.ti.com/clocks">www.ti.com/clocks</a>
Interface	<a href="http://interface.ti.com">interface.ti.com</a>
Logic	<a href="http://logic.ti.com">logic.ti.com</a>
Power Mgmt	<a href="http://power.ti.com">power.ti.com</a>
Microcontrollers	<a href="http://microcontroller.ti.com">microcontroller.ti.com</a>
RFID	<a href="http://www.ti-rfid.com">www.ti-rfid.com</a>
OMAP Mobile Processors	<a href="http://www.ti.com/omap">www.ti.com/omap</a>
Wireless Connectivity	<a href="http://www.ti.com/wirelessconnectivity">www.ti.com/wirelessconnectivity</a>

### Applications

Communications and Telecom	<a href="http://www.ti.com/communications">www.ti.com/communications</a>
Computers and Peripherals	<a href="http://www.ti.com/computers">www.ti.com/computers</a>
Consumer Electronics	<a href="http://www.ti.com/consumer-apps">www.ti.com/consumer-apps</a>
Energy and Lighting	<a href="http://www.ti.com/energy">www.ti.com/energy</a>
Industrial	<a href="http://www.ti.com/industrial">www.ti.com/industrial</a>
Medical	<a href="http://www.ti.com/medical">www.ti.com/medical</a>
Security	<a href="http://www.ti.com/security">www.ti.com/security</a>
Space, Avionics and Defense	<a href="http://www.ti.com/space-avionics-defense">www.ti.com/space-avionics-defense</a>
Transportation and Automotive	<a href="http://www.ti.com/automotive">www.ti.com/automotive</a>
Video and Imaging	<a href="http://www.ti.com/video">www.ti.com/video</a>

TI E2E Community Home Page

[e2e.ti.com](http://e2e.ti.com)

Mailing Address: Texas Instruments, Post Office Box 655303, Dallas, Texas 75265  
Copyright © 2011, Texas Instruments Incorporated