



ELECTRONICS, INC.  
 44 FARRAND STREET  
 BLOOMFIELD, NJ 07003  
 (973) 748-5089  
<http://www.nteinc.com>

## NTE74LS21 Integrated Circuit TTL – Dual 4–Input Positive AND Gate

**Description:**

The NTE74LS21 contains two independent 4–Input AND gates in a 14–Lead plastic DIP type package.

**Absolute Maximum Ratings:** (Note 1)

Supply Voltage,  $V_{CC}$  ..... 7V  
 DC Input Voltage,  $V_{IN}$  ..... 7V  
 Operating Temperature Range,  $T_A$  ..... 0°C to +70°C  
 Storage Temperature Range,  $T_{stg}$  ..... –65°C to +150°C

Note 1. Unless otherwise specified, all voltages are referenced to GND.

**Recommended Operating Conditions:**

Parameter	Symbol	Min	Typ	Max	Unit
Supply Voltage	$V_{CC}$	4.75	5.0	5.25	V
High–Level Input Voltage	$V_{IH}$	2	–	–	V
Low–Level Input Voltage	$V_{IL}$	–	–	0.8	V
High–Level Output Current	$I_{OH}$	–	–	–0.4	mA
Low–Level Output Current	$I_{OL}$	–	–	8	mA
Operating Temperature Range	$T_A$	0	–	+70	°C

**Electrical Characteristics:** (Note 2, Note 3)

Parameter	Symbol	Test Conditions	Min	Typ	Max	Unit
Input Clamp Voltage	$V_{IK}$	$V_{CC} = \text{MIN}, I_I = -18\text{mA}$	–	–	–1.5	V
High Level Output Voltage	$V_{OH}$	$V_{CC} = \text{MIN}, V_{IL} = \text{MAX}, I_{OH} = -0.4\text{mA}$	2.7	3.4	–	V
Low Level Output Voltage	$V_{OL}$	$V_{CC} = \text{MIN}, V_{IH} = 2\text{V}, I_{OL} = 4\text{mA}$	–	0.25	0.4	V
		$V_{CC} = \text{MIN}, V_{IH} = 2\text{V}, I_{OL} = 8\text{mA}$	–	0.35	0.5	V
Input Current	$I_I$	$V_{CC} = \text{MAX}, V_I = 7\text{V}$	–	–	0.1	mA

Note 2. For conditions shown as MIN or MAX, use the appropriate value specified under “Recommended Operation Conditions”.

Note 3. All typical values are at  $V_{CC} = 5\text{V}, T_A = +25^\circ\text{C}$ .

**Electrical Characteristics (Cont'd):** (Note 2, Note 3)

Parameter	Symbol	Test Conditions	Min	Typ	Max	Unit
High Level Input Current	$I_{IH}$	$V_{CC} = \text{MAX}, V_I = 2.7V$	-	-	20	$\mu A$
Low Level Input Current	$I_{IL}$	$V_{CC} = \text{MAX}, V_I = 0.4V$	-	-	-0.4	mA
Short-Circuit Output Current	$I_{OS}$	$V_{CC} = \text{MAX}, \text{Note 4}$	-20	-	-100	mA
High Level Supply Current	$I_{CCH}$	$V_{CC} = \text{MAX}, V_I = 4.5V$	-	1.2	2.4	mA
Low Level Supply Current	$I_{CCL}$	$V_{CC} = \text{MAX}, V_I = 0V$	-	2.2	4.4	mA

Note 2. For conditions shown as MIN or MAX, use the appropriate value specified under "Recommended Operation Conditions".

Note 3. All typical values are at  $V_{CC} = 5V, T_A = +25^\circ C$ .

Note 4. Not more than one output should be shorted at a time, and the duration of the short-circuit should not exceed one second.

**Switching Characteristics:** ( $V_{CC} = 5V, T_A = +25^\circ C$  unless otherwise specified)

Parameter	Symbol	Test Conditions	Min	Typ	Max	Unit
Propagation Delay Time (From Any Input to Y Output)	$t_{PLH}$	$R_L = 2k\Omega, C_L = 15pF$	-	8	15	ns
	$t_{PHL}$		-	10	20	ns

**Function Table (Each Gate):**

Inputs				Output
A	B	C	D	Y
H	H	H	H	H
L	X	X	X	L
X	L	X	X	L
X	X	L	X	L
X	X	X	L	L

H = HIGH Voltage Level

L = LOW Voltage Level

X = Don't Care

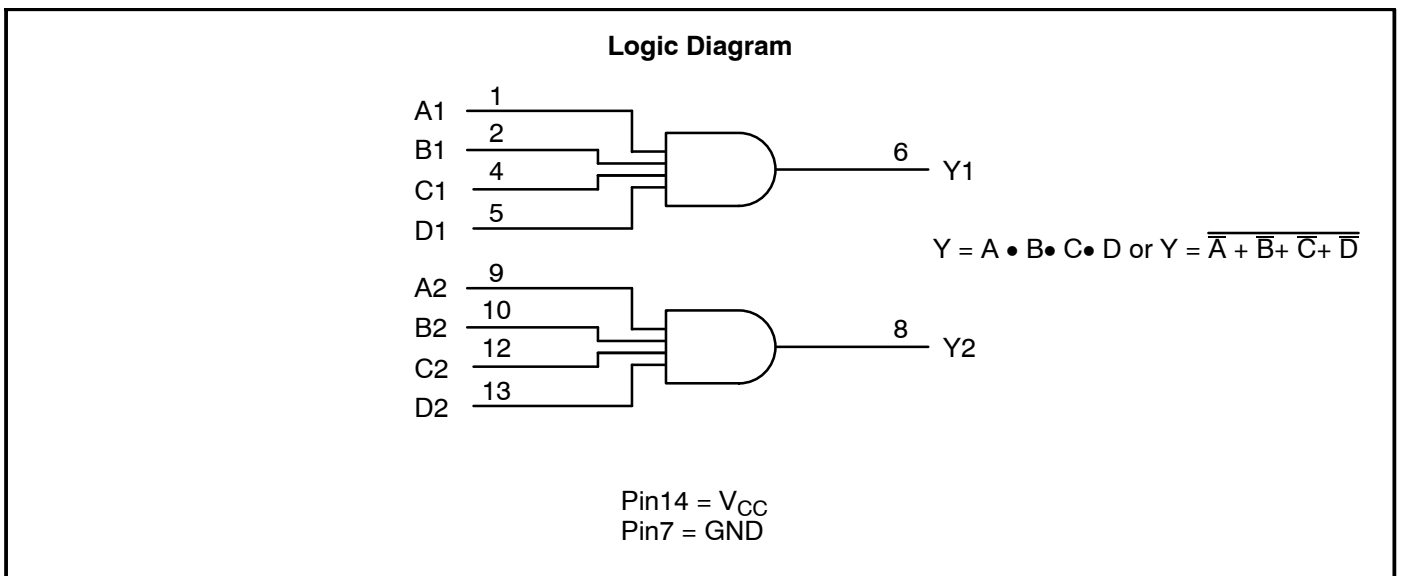

### Pin Connection Diagram

