

REV	DESCRIPTION	DATE

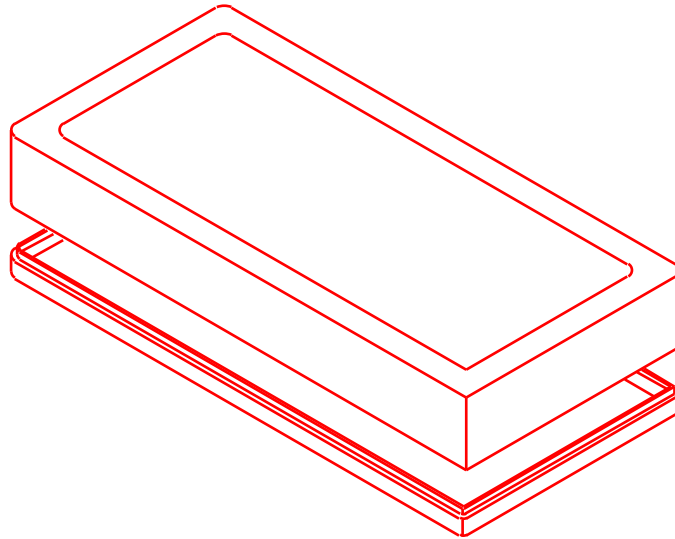

NOTES

MATERIAL (ABS) FLAME RETARDANT UL94 V0 MATERIAL WITH BRASS INSERTS IN CORNER POSTS,
(STYRENE) IS NON-FLAME RETARDANT WITHOUT BRASS INSERTS.

PARTS (ABS) VERSION MACHINE SCREWS M3-0.5 x 10mm,
REPLACEMENT PN 1591MS100 (100 / BAG), (STYRENE)
VERSION SELF TAPPING #4 x 0.5",
REPLACEMENT PN 1591TS100 (100 / BAG),

COLORS (ABS) BLACK, & GRAY, (STYRENE) GRAY ONLY,

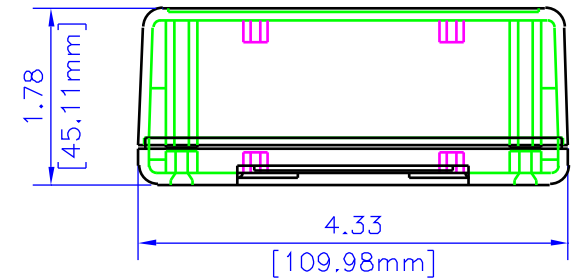
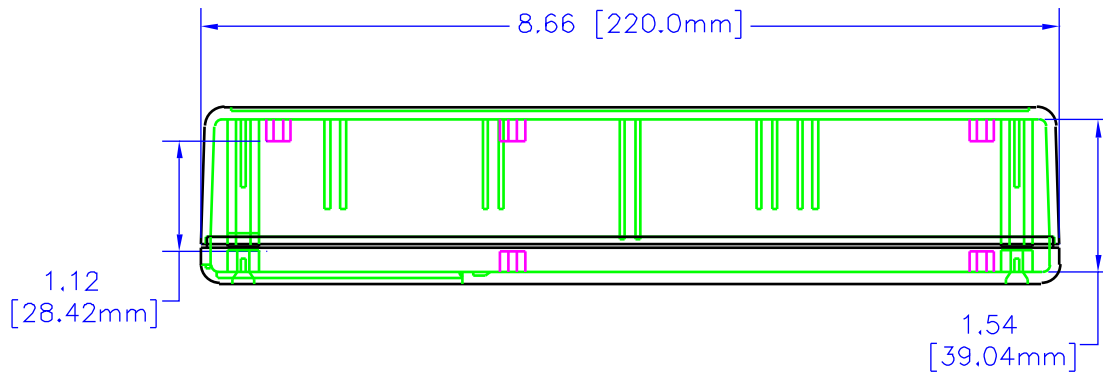

ASSEMBLED

UNLESS OTHERWISE SPECIFIED DIMENSIONS ARE IN INCHES.
x +/- .1
xx +/- .02
xxx +/- .015
CUTS +/- .005
ANGLES +/- .5 DEG.
NOTES:
HAMMOND CLAIMS PROPRIETARY RIGHTS TO THE MATERIAL ON THIS DRAWING, IT IS INTENDED TO BE USED AS A REFERENCE FOR ENGINEERING INFORMATION ONLY. THIS INFORMATION MAY NOT BE USED TO MANUFACTURE PRODUCT WITHOUT WRITTEN PERMISSION FROM HAMMOND MANUFACTURING.



**HAMMOND
MANUFACTURING**

WEB: WWW.HAMMONDMFG.COM

TITLE	
HAMMOND 1599 SERIES PLASTIC ENCLOSURE	
DRAWN BY	DATE
MJM	07/06/01
SCALE	PAGE
	1 OF 3
PART NUMBER	
1599HBAT	

NOTES

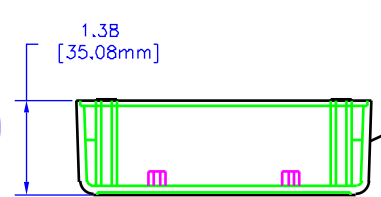
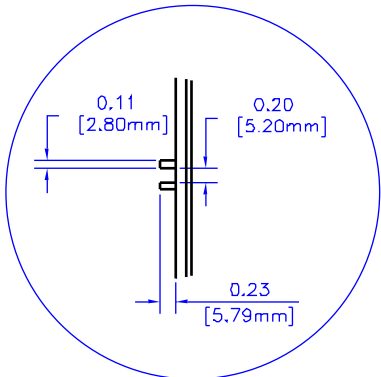
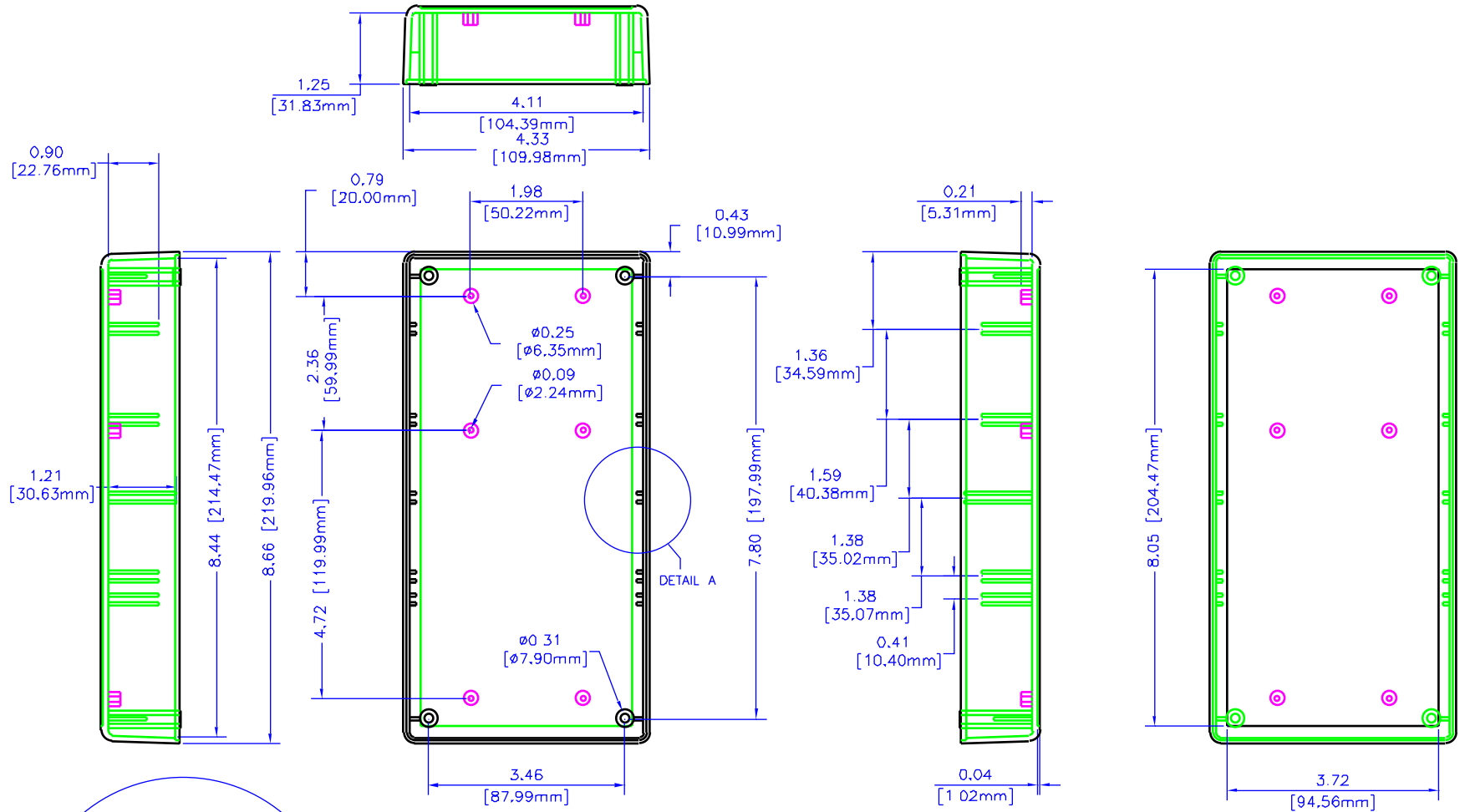

APPROXIMATE 2 DEG. DRAFT ANGLE

BOX

UNLESS OTHERWISE SPECIFIED DIMENSIONS ARE IN INCHES	
X	+/- .1
XX	+/- .02
XXX	+/- .015
FILLS	+/- .005
ANGLES	+/- 8 DEG
NOTES	
HAMMOND OWNS PROPRIETARY RIGHTS TO THE MATERIAL ON THIS DRAWING. IT IS INTENDED TO BE USED AS A REFERENCE FOR ENGINEERING INFORMATION ONLY. THIS INFORMATION MAY NOT BE USED TO MANUFACTURE PRODUCT WITHOUT WRITTEN PERMISSION FROM HAMMOND MANUFACTURING.	



WEB: WWW.HAMMONDMFG.COM

TITLE	
HAMMOND 1599 SERIES PLASTIC ENCLOSURE	
DRAWN BY	MJM
DATE	07/06/01
SCALE	
PAGE	2 OF 3
PART NUMBER	
1599HBT	

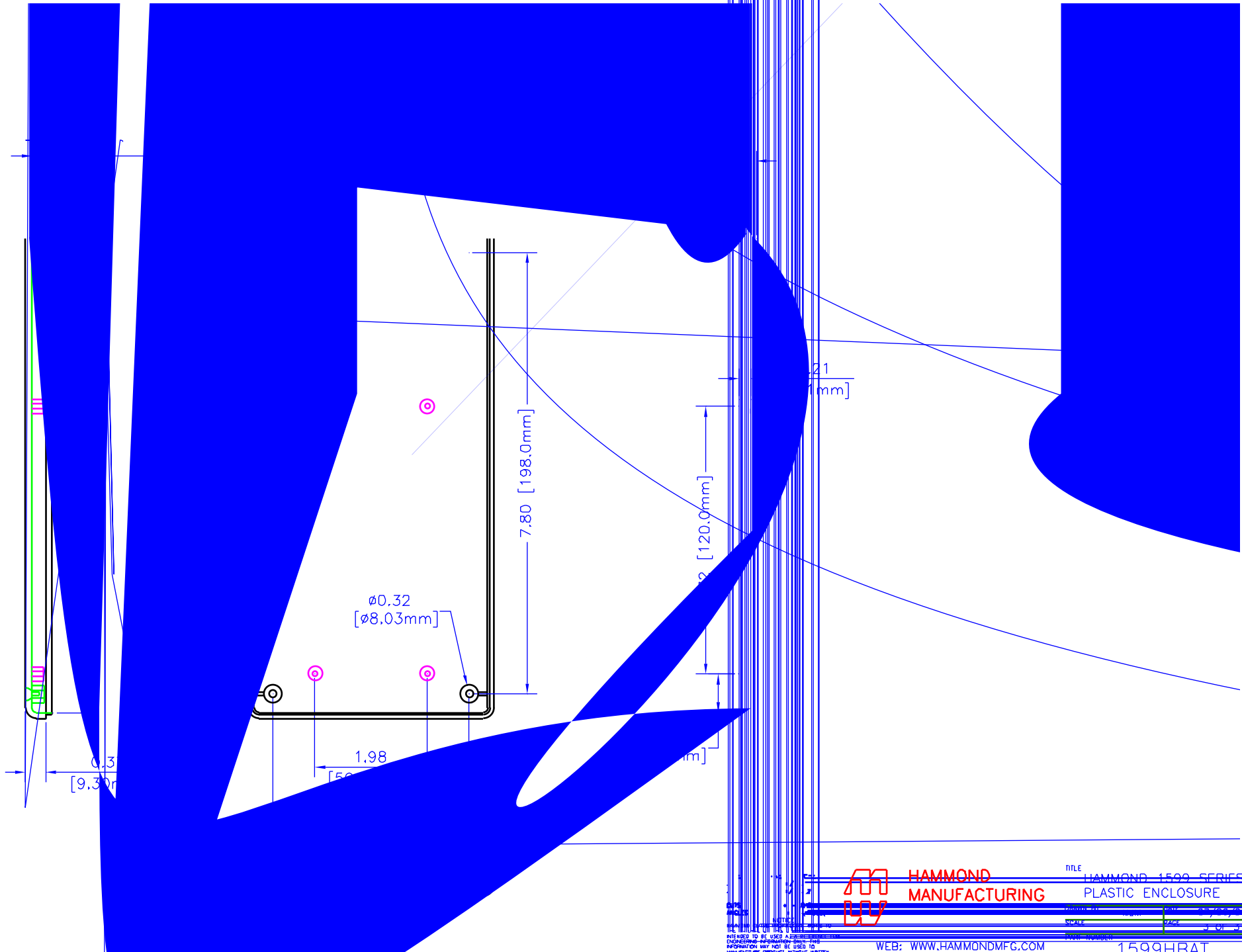

**HAMMOND
MANUFACTURING**

TITLE
HAMMOND 1599 SERIES
PLASTIC ENCLOSURE

NOTES:
1. DIMENSIONS ARE IN MILLIMETERS UNLESS OTHERWISE SPECIFIED.
2. DIMENSIONS MAY VARY WITHOUT NOTICE.
3. DIMENSIONS MAY VARY WITHOUT NOTICE.
4. DIMENSIONS MAY VARY WITHOUT NOTICE.
5. DIMENSIONS MAY VARY WITHOUT NOTICE.
6. DIMENSIONS MAY VARY WITHOUT NOTICE.
7. DIMENSIONS MAY VARY WITHOUT NOTICE.
8. DIMENSIONS MAY VARY WITHOUT NOTICE.
9. DIMENSIONS MAY VARY WITHOUT NOTICE.
10. DIMENSIONS MAY VARY WITHOUT NOTICE.

WEB: WWW.HAMMONDMFG.COM

1599HBAT