

- 1
- 2
- 3
- 4
- 5
- 6
- 7
- 8
- 9
- 10
- 11
- 12
- 13
- 14
- 15
- 16
- 17
- 18

1 **THREADED BODY**

Zinc-plated steel.

2 **PLUNGER**

AISI 303 stainless steel.

Suggested tolerance for matching hole = G7.

3 **KNOB**

Glass-fibre reinforced polyamide based (PA) technopolymer, black colour, matte finish.

4 **CENTRE CAP**

Glass-fibre reinforced polyamide-based (PA) technopolymer, colour light grey.

5 **FEATURES AND APPLICATIONS**

Indexing plungers with locking knob are used to position, to lock and to make secure elements whose position needs to be changed such as guides, plates etc.

By axially lifting the knob, the spring pressure is overcome hence the plunger is retracted, allowing the positioning adjustment. By turning the knob which is connected to the threaded body by means of a special hexagonal insert, the positioning of the plunger is locked.

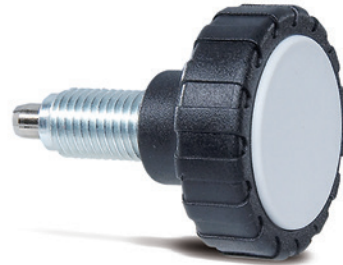

Assembly example

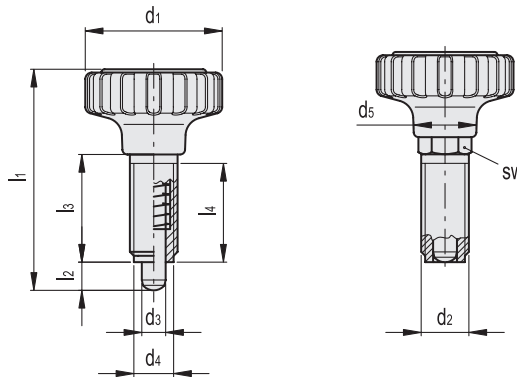
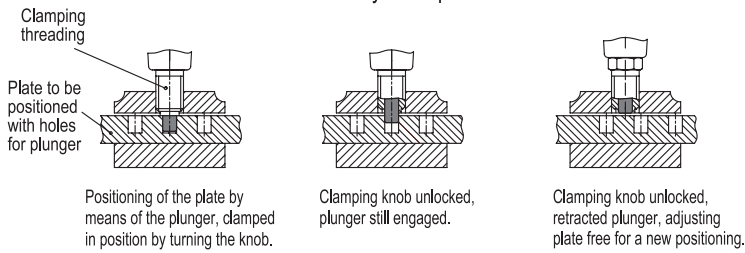

Code	Description	d3										Spring preload [N]	Spring max load [N]	⚖️
		d1	d2	Plunger -0.02 -0.04 Hole G7	d4	d5	l1	l2	l3	l4	sw			
GN.29241	GN 7336.7-34-M10x1-5	34	M10x1	5	8.6	15.5	44	5	19	17	10	7	17	15
GN.29246	GN 7336.7-42-M12x1.5-6	42	M12x1.5	6	9.9	19	52	6	21	19	12	9	24	41
GN.29251	GN 7336.7-53-M12x1.5-6	53	M12x1.5	6	9.9	22.5	59	6	21	19	12	9	24	60
GN.29253	GN 7336.7-53-M16x1.5-8	53	M16x1.5	8	13.9	22.5	68	8	28	26	16	11	30	90