

SMD-LED-Anzeigesysteme

SMD LED Display Systems

In die Entwicklung dieser oberflächenmontierbaren Bausteine ist das über Jahrzehnte erworbene Know-how der Firma MENTOR als Entwickler und Lieferant von Bauelementen für die Industrie-elektronik geflossen.

Umfangreiche Untersuchungen, teilweise im Rahmen eines Forschungsprojektes, sind bei der Gestaltung berücksichtigt.

Die SMD's stehen als Einzel- und als Doppel-LED-Bausteine in den verschiedensten Abmessungen, je nach Anwendungsfall, zur Verfügung.

Besonderen Wert wurde auf die Anschlussausführung als GullWings gelegt, da diese aufgrund ihrer Vorteile, wie reproduzierbare Rastermaße, Selbstzentrierungseffekte, verbesserte Löt-schatenproblematik, gute visuelle Lötstelleninspektion und einfaches Nach- und Auslöten, die größte Verbreitung gefunden hat.



The development of these surface-mounted components was based on the decades of know-how of MENTOR as a developer and supplier of components for industrial electronics.

Extensive research, partly as part of a research project, was taken into account in the design.

The SMDs are available as single and double LED modules in diverse dimensions to suit particular application requirements.

Particular importance was attached to their connections as gull wings, as these are the most widely used form due to their advantages such as reproducible grid dimensions, self-centering features, improved shadowing problematic, good visual soldered joint inspection and easy resoldering and unsoldering.

Allgemeine Technische Daten	(Auswahl bzw. Abweichungen zu den folgenden allgem. Daten: siehe Beschreibung des jeweiligen Artikels)
Koplanarität über alle Lötflächen	≤ 0,1mm
Lötwärmebeständigkeit	nach CECC 00802 / DIN 45802 - 260°C 10s
Lötbarkeit	DIN IEC 68-2-20
UL-Listung	auf Anfrage
Betriebstemperatur	-40°C ... +85°C
Klima	GPF DIN 40040
Gehäusewerkstoff	Thermoplast glasfaserverstärkt
Gehäusefarben	Standard grau, andere Farben auf Anfrage möglich
Anschlüsse	verzinkt
Verpackung	Blistergurte nach DIN EN 60286-3; Stangenmagazine, Trays sowie spezielle antistatische Ausführung auf Anfrage möglich
Spulen	Standardkunststoffspulen primär Ø330mm, andere Ausführungen auf Anfrage
Beschriftung	je nach Ausführung bedruckt oder gelasert
Bestückung mit LED's	Ausführung und Technische Daten siehe Seite 53
Sonderwünsche	Sonderbestückung, Verwendung von zusätzlichen Fixierpins sowie umgekehrte Polarität auf Anfrage möglich
Mindestbestimmungen für Sonderausführungen auf Anfrage.	

General Technical Data	(Selection and deviations from the following general data: see description of the respective item)
Coplanarity above all soldering surfaces	≤ 0,1mm
Resistance to soldering heat	to CECC 00802 / DIN 45802 - 260°C 10s
Solderability	DIN IEC 68-2-20
UL listing	Available on request
Operating temperature	-40°C ... +85°C
Climate	GPF DIN 40040
Housing material	Glass fiber reinforced thermoplastic
Housing colors	Standard grey, other colors available on request
Terminals	tinned
Packaging	Tape and reel packed to DIN EN 60286-3; sticks, trays and special antistatic types on request
Reel	Standard plastic reel mainly Ø330mm, other applications on request
Marking	Depending on type printed or laser printed
LEDs	Type and technical data, see page 53
Special requirements	Special components, use of additional fixing pins and reverse polarity on request
Minimum quantity for special design on request.	

Ø3mm Einzel-LED's liegend

Ø3mm Single LEDs lying

Allgemeine Hinweise und Technische Daten

Allgemeine Hinweise und Technische Daten: siehe Seite 23
Technische Daten LED's: siehe Seite 49

General Remarks and Technical Data

General Remarks and Technical Data: see page 23
Technical Data LEDs: see page 49

Der Baustein 2638 ermöglicht durch seine besonders schlanke Bauform von 3,8mm ein dichtes Aneinanderreihen der Bauelemente zu LED-Zeilen.

The slimline 2638 series module measuring only 3.8mm, enables the components to be arranged closely side by side to form LED lines.



Blistergurtverpackung DIN EN 60286-3
Tape and reel packed DIN EN 60286-3
 $K_0=6,2 \cdot W=24 \cdot P_1=16$

600 Stück pro Rolle
600 pieces per reel

Farbe · Color	LED-Type	Art.-Nr.
	super-red	A72
	yellow	A58
	green	A59

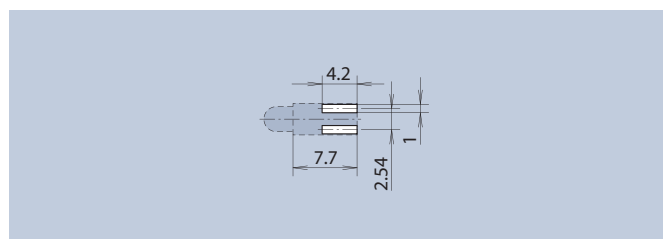
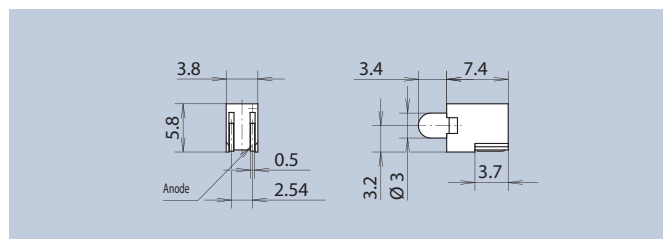

Layoutvorschlag · Layout Suggestion

Spezifische Technische Daten

Gehäusefarbe: schwarz

Specific Technical Data

Housing color: black

Die Bauelemente der 2625-er Serie bieten die Möglichkeit der horizontalen LED-Abstrahlung. Die LED kann zwischen verschiedenen Qualitäten und Farben ausgewählt werden. Alle Versionen sind auf Bestückungsautomaten einsetzbar.

2625 series components offer the option of horizontal LED radiation. The LED is available in different qualities and colors. All versions can be used on insertion machines.



FEL

Blistergurtverpackung DIN EN 60286-3
Tape and reel packed DIN EN 60286-3
 $K_0=7,3 \cdot W=24 \cdot P_1=8$

1.200 Stück pro Rolle
1.200 pieces per reel

Farbe · Color	LED-Type	Art.-Nr.
	super-red	A72
	yellow	A58
	green	A59

Low Current Ausführung · Low Current Version



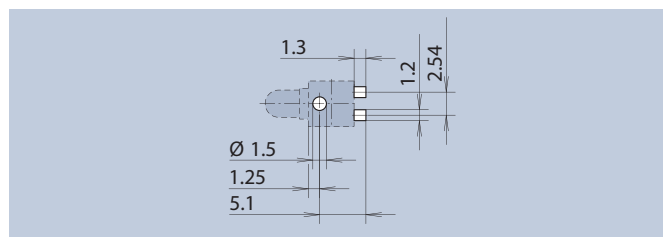
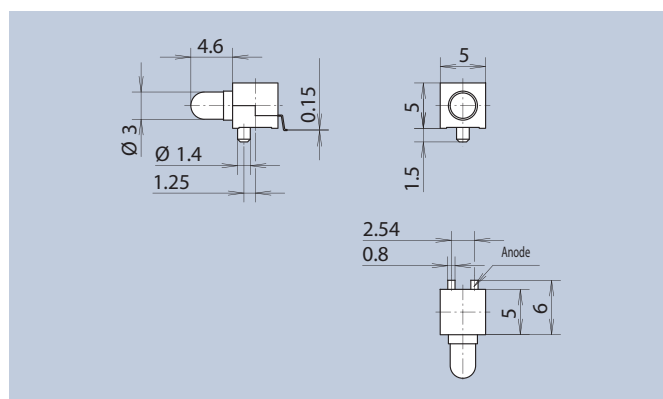

























Farbe · Color	LED-Type	Art.-Nr.
	super-red	A66
	yellow	A67
	green	A68



Layoutvorschlag · Layout Suggestion

Technische Daten THT LED's

Technical Data THT LEDs

LED-Type		Emission Color	Wavelength	Lense Color	Forward Voltage V _F (V)		Luminous Intensity I _V (mcd)			at	Fwd. Current I _F max (mA)	Rev. Voltage V _R (V)	2φ (50% I _V) deg.
			λ (nm) dominant		typ	max	min	typ	max	mA			
THT													
A	38	 bright-red	660	 red diffused	2,25	2,5				20	25	5	100
A	40	 yellow	588	 yellow diffused	2,1	2,5	0,4	-	1,5	20	30	5	100
A	41	 green	568	 green diffused	2,2	2,5	3	-	12	20	25	5	100
A	58	 yellow	587	 yellow diffused	2	2,5	7,1	-	18	10	40	12	70
A	59	 green	570	 green diffused	2	2,5	7,1	-	18	10	40	12	70
A	66	 super-red	628	 red diffused	1,8	2,5	1,12	-	4,5	2	7,5	12	60
A	67	 yellow	587	 yellow diffused	2	2,6	1,12	-	4,5	2	7,5	12	60
A	68	 green	570	 green diffused	1,9	2,5	1,12	-	4,5	2	7,5	12	60
A	69	 super-red	628	 red diffused	2	2,5	7,1	-	18	10	40	12	50
A	70	 yellow	587	 yellow diffused	2	2,5	7,1	-	18	10	40	12	50
A	71	 green	570	 green diffused	2	2,5	7,1	-	18	10	40	12	50
A	72	 super-red	628	 red diffused	2	2,5	7,1	-	18	10	40	12	70
N	1	 super-red	635 (peak)	colorless clear	2,1	-	-	2,5	-	20	25	5	60
N	2	 yellow	585 (peak)	colorless clear	2,1	-	-	2	-	20	25	5	60
N	3	 green	565 (peak)	colorless clear	2,1	-	-	4	-	20	25	5	60
Argus													
A	15	 super-red	628	 red clear	2,1	2,5	45	-	71	15	40	12	-