

System Lens Drivers

# μ-step System Lens Driver for Digital Still Cameras

## BU24036MWV

### General Description

BU24036MWV is a system Lens Driver which is capable of μ-step driving and possible to configure a high precision and low noise lens driver system. This device performs μ-step driving control internally and can reduce a load of CPU. This device also has drivers for DC motor and voice coil motor, and is utilizable for multifunctional lens.

### Features

- Built-in 6 Channel Drivers  
1ch to 4ch: Voltage Control Type H-Bridge (for 2 STM Systems)  
5ch: Voltage/Current Control Type H-Bridge  
6ch: Current Control Type H-Bridge
- Built-in 2 Channel PI Driver Circuits
- Built-in 1 Channel Waveform Shaping Circuit
- Built-in FLL Digital Servo Circuit
- Built-in PLL Circuit
- Built-in STM Control Circuit: Autonomous Control (cache, Acceleration/deceleration Mode), Clock IN Control

### Applications

- Digital Still Camera

### Key Specifications

- I/O Power Supply Voltage: 1.62 V to 3.6 V
- Digital Power Supply Voltage: 2.7 V to 3.6 V
- Driver Power Supply Voltage: 2.7 V to 5.5 V
- Input/Output Current (1ch to 4ch,6ch): 500 mA (Max)
- Input/Output Current (5ch): 600 mA (Max)
- Clock Operating Frequency: 1 MHz to 28 MHz
- ON-Resistance (1ch, 2ch): 2.0 Ω (Typ)
- ON-Resistance (3ch, 4ch): 1.5 Ω (Typ)
- ON-Resistance (5ch,6ch): 1.0 Ω (Typ)
- Operating Temperature Range: -20 °C to +85 °C

### Package

UQFN040V5050

### W (Typ) x D (Typ) x H (Max)

5.00 mm x 5.00 mm x 1.00 mm

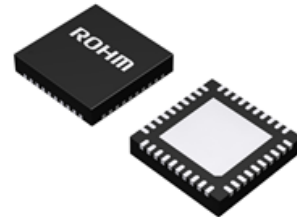

### Typical Application Circuit

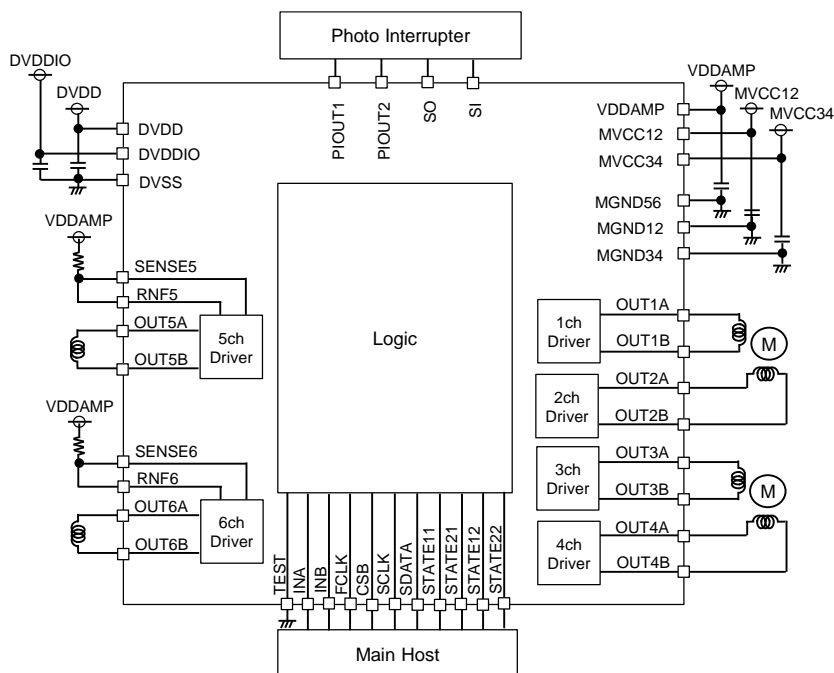

○Product structure : Silicon integrated circuit ○This product has no designed protection against radioactive rays

## Contents

General Description .....	1
Features .....	1
Applications .....	1
Key Specifications.....	1
Package .....	1
Typical Application Circuit.....	1
Contents.....	2
Pin Configuration .....	3
Pin Description.....	4
Block Diagram .....	5
Description of Blocks.....	6
Absolute Maximum Ratings .....	9
Recommended Operating Conditions .....	9
Electrical Characteristics .....	10
Typical Performance Curves.....	11
Timing Chart .....	15
Serial interface.....	16
Register Map .....	16
Application Example.....	17
I/O Equivalence Circuit.....	18
Operational Notes .....	20
Ordering Information .....	22
Marking Diagram.....	22
Physical Dimension and Packing Information .....	23
Revision History.....	24

Pin Configuration

(Top view)

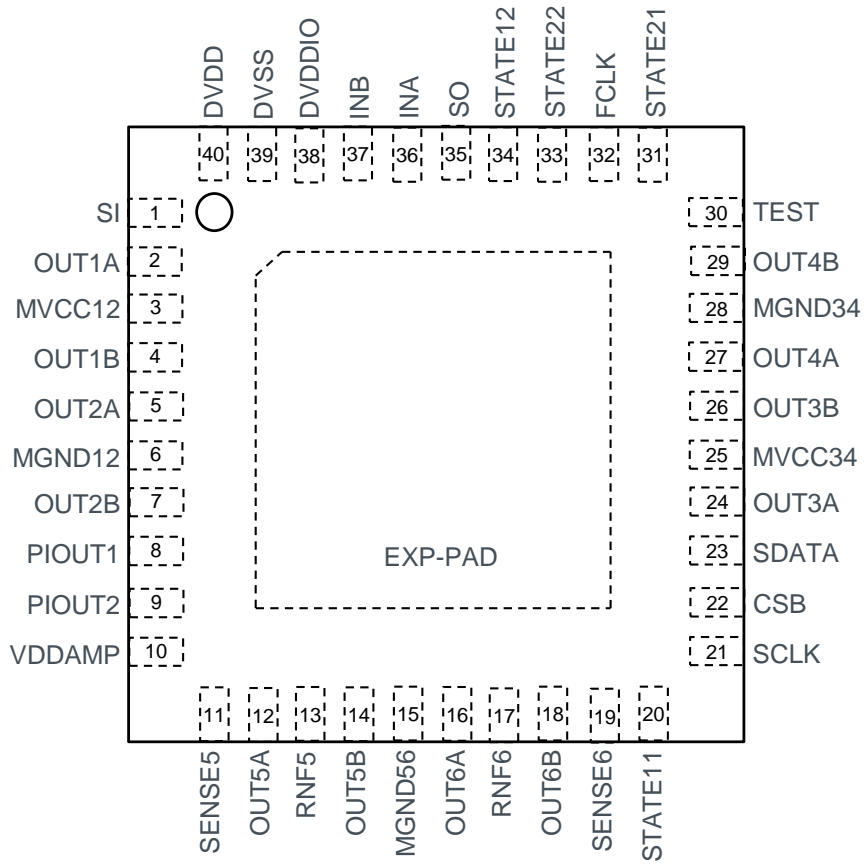

## Pin Description

Pin No.	Pin Name	Power Supply	Function	Pin No.	Pin Name	Power Supply	Function
1	SI	DVDD	Waveform shaping input	22	CSB	DVDDIO	CSB logic input
2	OUT1A	MVCC12	1ch driver A output	23	SDATA	DVDDIO	SDATA logic input
3	MVCC12	-	1ch, 2ch driver power supply	24	OUT3A	MVCC34	3ch driver A output
4	OUT1B	MVCC12	1ch driver B output	25	MVCC34	-	3ch, 4ch driver power supply
5	OUT2A	MVCC12	2ch driver A output	26	OUT3B	MVCC34	3ch driver B output
6	MGND12	-	1ch, 2ch driver ground	27	OUT4A	MVCC34	4ch driver A output
7	OUT2B	MVCC12	2ch driver B output	28	MGND34	-	3ch, 4ch driver ground
8	PIOUT1	DVDD	PI driving output 1	29	OUT4B	MVCC34	4ch driver B output
9	PIOUT2	VDDAMP	PI driving output 2	30	TEST	DVDDIO	TEST logic input
10	VDDAMP	-	5ch, 6ch power supply of driver control	31	STATE21	DVDDIO	STATE21 logic input/output
11	SENSE5	VDDAMP	Negative input for 5ch current driver	32	FCLK	DVDDIO	FCLK logic input
12	OUT5A	RNF5	5ch driver A output	33	STATE22	DVDDIO	STATE22 logic output
13	RNF5	-	5ch driver power supply	34	STATE12	DVDDIO	STATE12 logic output
14	OUT5B	RNF5	5ch driver B output	35	SO	DVDDIO	Waveform shaping output
15	MGND56	-	5ch, 6ch driver ground	36	INA	DVDDIO	INA logic input
16	OUT6A	RNF6	6ch driver A output	37	INB	DVDDIO	INB logic input
17	RNF6	-	6ch driver power supply	38	DVDDIO	-	I/O power supply
18	OUT6B	RNF6	6ch driver B output	39	DVSS	-	Ground
19	SENSE6	VDDAMP	Negative input for 6ch current driver	40	DVDD	-	Digital power supply
20	STATE11	DVDDIO	STATE11 logic input/output	-	EXP-PAD	-	Left electrically open or short to ground.
21	SCLK	DVDDIO	SCLK logic input				

Block Diagram

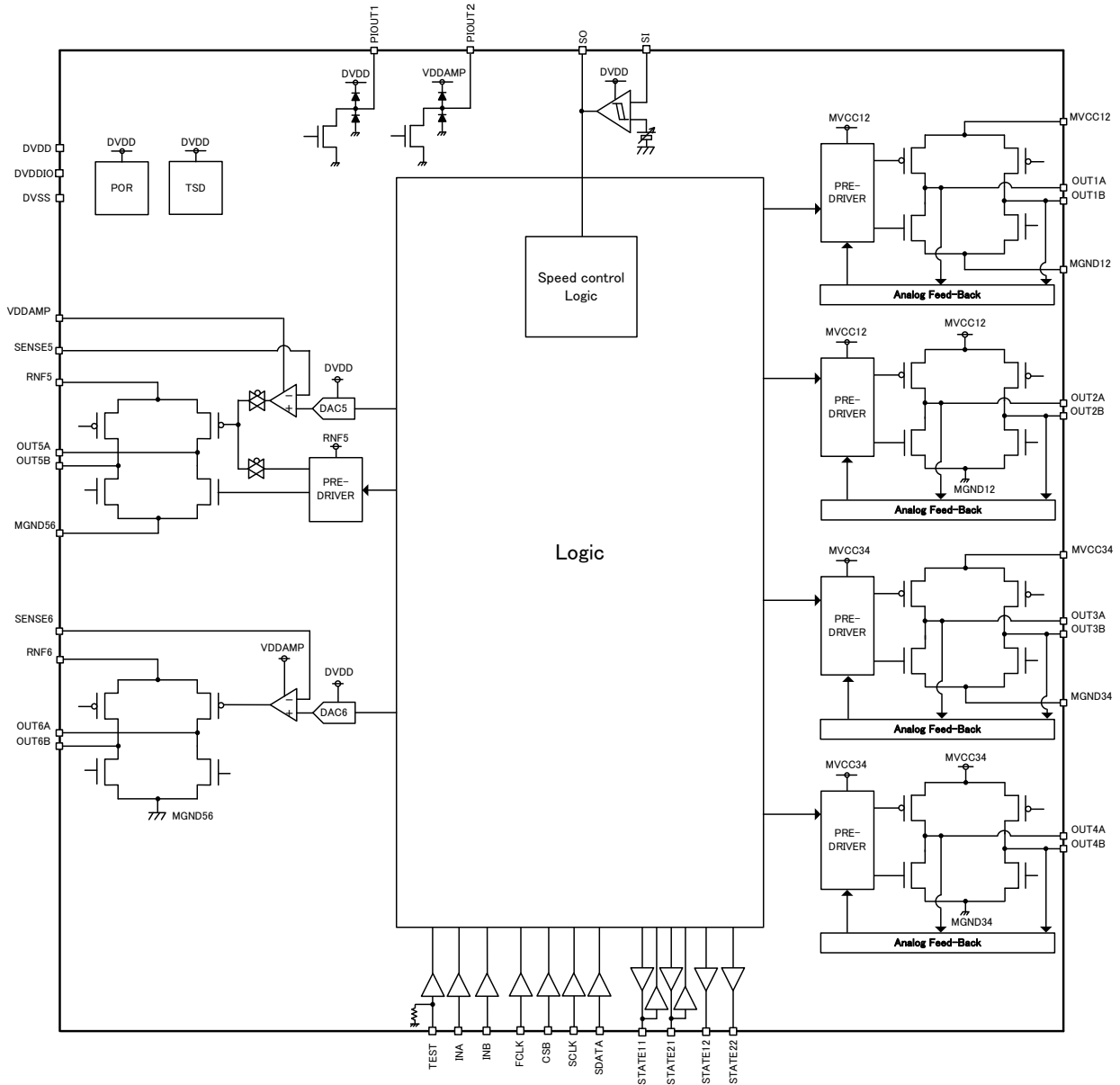

## Description of Blocks

### Stepping Motor Driver (1ch to 4ch Driver)

- Built-in PWM type stepping motor drivers.
- Maximum 2 stepping motors can be driven independently.
- Built-in D-class type voltage feedback circuit.
- 3ch/4ch drivers can also drive DC motor or voice coil motor individually.

#### (1) Control

Both Clock IN and Autonomous control are possible.

##### (a) Clock IN Control

Set the registers for the stepping motor control.

Stepping motor rotates in synchronization with clock input to the STATE11 pin and/or the STATE21 pin.

Mode of stepping motor control is selectable from  $\mu$ -step, 1-2 phase excitation and 2 phase excitation. And the number of edge for electrical angle cycle is selectable from 4, 8, 32, 64, 128, 256, 512 or 1024.

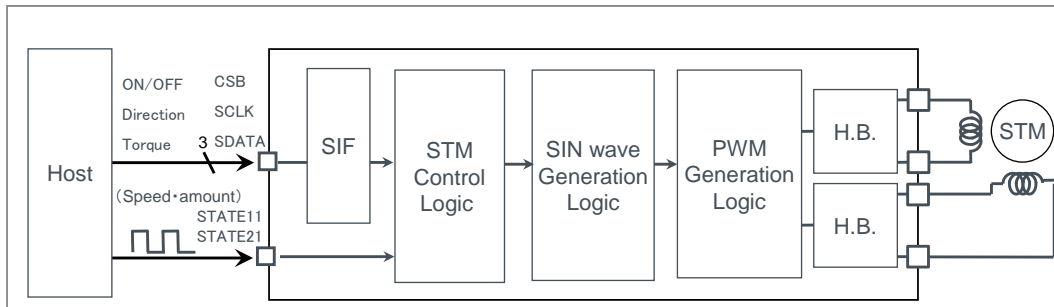

##### (b) Autonomous Control

Stepping motor rotates by setting the registers to drive the stepping motor.

Mode of stepping motor control is selectable from  $\mu$ -step (1024 portion), 1-2 phase excitation and 2 phase excitation.

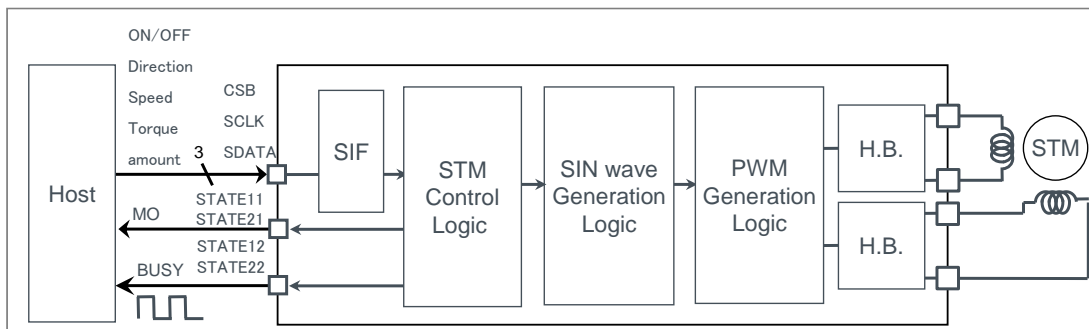

### Cache Mode

Built-in Cache register enables to set next operation commands during motor operation, and continuous operation is possible. It is possible to output from the STATE11, the STATE21, the STATE12 and the STATE22 pins the status information which is selectable from operation command status(ACT), cache register status(BUSY), motor rotation position(MO) or excitation status(MO&EN) in synchronization with motor operation.

### Acceleration/deceleration Mode

Acceleration, constant and deceleration operation can be processed in a batch by setting rotation commands together before motor operation.

It is possible to output from the STATE11, the STATE21, the STATE12 and the STATE22 pins the status information which is selectable from operation command status(ACT), acceleration/deceleration status(BUSY), motor rotation position(MO) or excitation status(MO&EN) in synchronization with motor operation.

**Description of Blocks – continued**

Voltage/Current Driver (5ch Driver)

Built-in PWM type voltage/constant current selectable driver.  
 Built-in digital FLL speed control logic for voltage driver.

(1) Control

(a) Register Control

■ Voltage Driver (speed control = OFF)

PWM driving by setting the registers for PWM duty ratio, direction and ON/OFF.

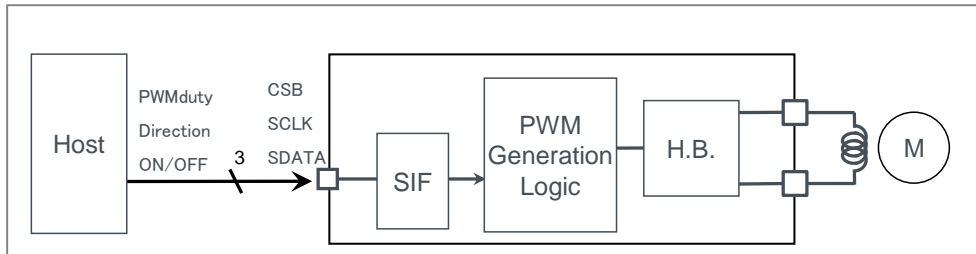

■ Voltage Driver (speed control = ON)

Speed control driving by setting the registers for target speed value, PI filter value, direction and ON/OFF. Motor speed is detected from photo-interrupter signal and rotation speed is adjusted by comparing the target speed with the motor speed.

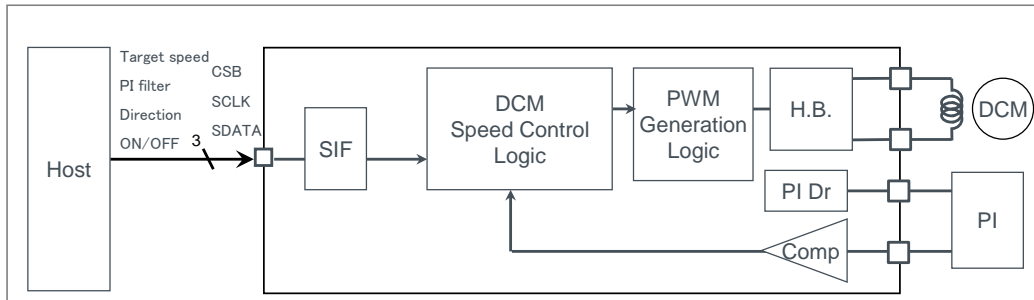

■ Current Driver

Constant current driving by setting the registers for output current value, direction and ON/OFF.

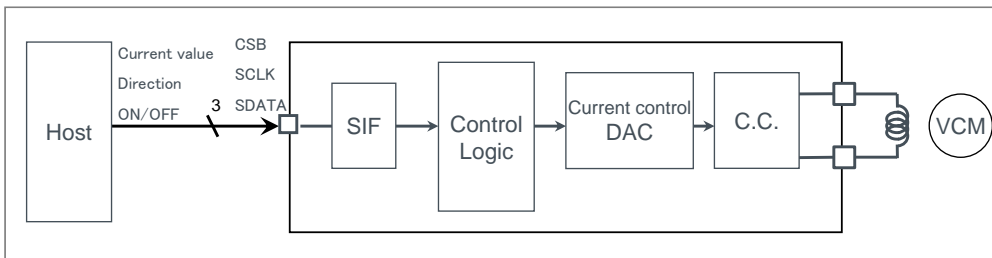

**Description of Blocks – continued**

(b) External Pin Control

■ Voltage Driver (speed control = OFF)

PWM driving by setting the registers for PWM duty ratio, and the INA and INB pins for direction and ON/OFF. (This is not applicable when speed control is ON.)

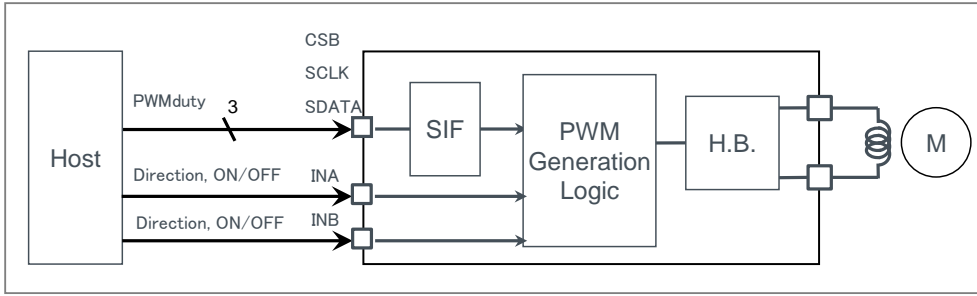

■ Current Driver

Constant current driving by setting the registers for output current value, and the INA and INB pins for direction and ON/OFF.

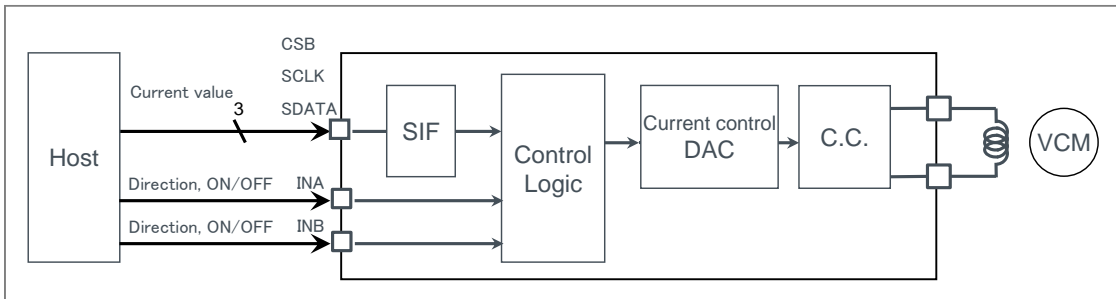

Current Driver (6ch Driver)

Built-in constant current driver.

A voltage at the RNF6 pin and an external resistor ( $R_{RNF}$ ) value determine output current value. An internal high-precision amplifier (CMOS gate input) controls constant current. If any resistance component exists in wirings for the RNF6 pin and the external resistor ( $R_{RNF}$ ), that might reduce accuracy and pay attention about wiring.

(1) Control

(a) Register Control

Constant current driving by setting the registers for output current value, direction and ON/OFF.

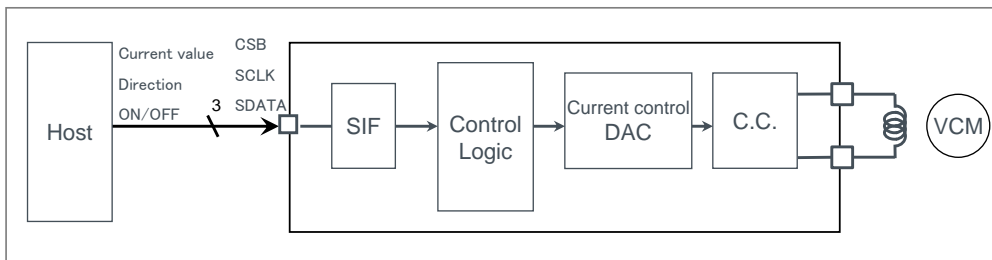

(b) External Pin Control

Constant current driving by setting the registers for output current value, and the INA and INB pins for direction and ON/OFF.

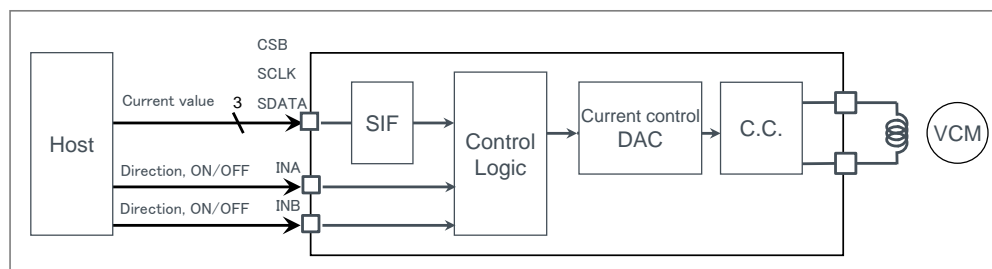



## Absolute Maximum Ratings (Ta=25 °C)

Parameter	Symbol	Rating	Unit	Remark
Supply Voltage	DVDDIO	-0.3 to +4.5	V	
	DVDD	-0.3 to +4.5	V	
	MVCC	-0.3 to +7.0	V	MVCC12, MVCC34, VDDAMP
Input Voltage	V <sub>IN</sub>	-0.3 to supply voltage+0.3	V	
Input / Output Current <sup>(Note 1)</sup>	I <sub>IN</sub>	500	mA	MVCC12, MVCC34, RNF6
		600	mA	RNF5
		50	mA	PIOUT1
		150	mA	PIOUT2
Maximum Junction Temperature	T <sub>jmax</sub>	125	°C	
Storage Temperature Range	T <sub>stg</sub>	-55 to +125	°C	
Power Dissipation <sup>(Note 2)</sup>	P <sub>d</sub>	2.60	W	

**Caution 1:** Operating the IC over the absolute maximum ratings may damage the IC. The damage can either be a short circuit between pins or an open circuit between pins and the internal circuitry. Therefore, it is important to consider circuit protection measures, such as adding a fuse, in case the IC is operated over the absolute maximum ratings.

**Caution 2:** Should by any chance the maximum junction temperature rating be exceeded the rise in temperature of the chip may result in deterioration of the properties of the chip. In case of exceeding this absolute maximum rating, design a PCB with power dissipation taken into consideration by increasing board size and copper area so as not to exceed the maximum junction temperature rating.

(Note 1): Must not exceed P<sub>d</sub>.

(Note 2): When use at Ta=25 °C or more, derate 26 mW per 1 °C

(At mounting 74.2 mm x 74.2 mm x 1.6 mm, 4 layer board, Cu foil for heat dissipation on surface 6.28mm<sup>2</sup>)

## Recommended Operating Conditions

Parameter	Symbol	Min	Typ	Max	Unit	Remark
I/O Power Supply Voltage	DVDDIO	1.62	3.0	3.6	V	
Digital Power Supply Voltage	DVDD	2.7	3.0	3.6	V	DVDD ≤ MVCC
Driver Power Supply Voltage	MVCC	2.7	5.0	5.5	V	MVCC12, MVCC34, VDDAMP
Clock Operating Frequency	f <sub>FCLK</sub>	1	-	28	MHz	Reference clock
Operating Temperature	T <sub>opr</sub>	-20	+25	+85	°C	

## Electrical Characteristics

(Unless otherwise specified Ta=25 °C, DVDDIO=DVDD=3.0 V, MVCC12=MVCC34=VDDAMP=5.0 V)

Parameter	Symbol	Min	Typ	Max	Unit	Conditions
<Current Consumption>						
Quiescent Current	I <sub>SSDO</sub>	-	0	10	μA	DVDDIO power supply CMD_RS=0
	I <sub>SSD</sub>	-	50	95	μA	DVDD power supply CMD_RS=0
	I <sub>SSM</sub>	-	0	10	μA	MVCC power supply CMD_RS=0
Operational Current	I <sub>DDDO</sub>	-	0.1	1	mA	DVDDIO power supply CMD_RS=STB=CLK_EN=1 f <sub>CLK</sub> = 24 MHz CLK_DIV setting: 0h No load
	I <sub>DDD</sub>	-	6	10	mA	DVDD power supply CMD_RS=STB=CLK_EN=1 f <sub>CLK</sub> = 24 MHz CLK_DIV setting: 0h No load
<Logic Block>						
Low-Level Input Voltage	V <sub>IL</sub>	DVSS	-	0.3 x DVDDIO	V	
High-Level Input Voltage	V <sub>IH</sub>	0.7 x DVDDIO	-	DVDDIO	V	
Low-Level Input Current	I <sub>IL</sub>	0	-	10	μA	V <sub>IL</sub> =DVSS
High-Level Input Current	I <sub>IH</sub>	0	-	10	μA	V <sub>IH</sub> =DVDDIO
Low-Level Output Voltage	V <sub>OL</sub>	DVSS	-	0.2 x DVDDIO	V	I <sub>OL</sub> = 1.0 mA
High-Level Output Voltage	V <sub>OH</sub>	0.8 x DVDDIO	-	DVDDIO	V	I <sub>OH</sub> = 1.0 mA
<PI Driver Circuit>						
Output Voltage	V <sub>PIO</sub>	-	0.15	0.5	V	I <sub>IH</sub> = 30 mA
<Waveform Shaping Circuit>						
Detection Voltage	V <sub>TH</sub>	1.4	1.5	1.6	V	Waveform_Vthh, Waveform_Vthl setting: 20h
<Voltage Driver Block 1ch-4ch>						
ON-Resistance	R <sub>ON</sub>	-	2.0	2.5	Ω	I <sub>o</sub> = ±100 mA (sum of high and low sides, 1ch, 2ch driver)
		-	1.5	2.0	Ω	I <sub>o</sub> = ±100 mA (sum of high and low sides, 3ch, 4ch driver)
OFF-Leak Current	I <sub>OZ</sub>	-10	0	+10	μA	Output HiZ setting
Accuracy of Average Voltage between Output Pins	V <sub>DIFF</sub>	-5	-	+5	%	different output voltage setting: 2Bh
<Voltage/Current Driver Block 5ch>						
ON-Resistance	R <sub>ON</sub>	-	1.0	1.5	Ω	I <sub>o</sub> = ±100 mA (sum of high and low sides)
OFF-Leak Current	I <sub>OZ</sub>	-10	0	+10	μA	Output HiZ setting
Output Current	I <sub>o</sub>	190	200	210	mA	In current driver mode 5_IOUT setting: 80h R <sub>RNF</sub> =1 Ω
<Current Driver Block 6ch>						
ON-Resistance	R <sub>ON</sub>	-	1.0	1.5	Ω	I <sub>o</sub> = ±100 mA (sum of high and low sides)
OFF-Leak Current	I <sub>OZ</sub>	-10	0	+10	μA	Output HiZ setting
Output Current	I <sub>o</sub>	190	200	210	mA	6_IOUT setting: 80h R <sub>RNF</sub> =1 Ω

**Typical Performance Curves**

(Unless otherwise specified Ta=25 °C, DVDDIO=DVDD=3.0 V, MVCC12=MVCC34=VDDAMP=5.0 V)

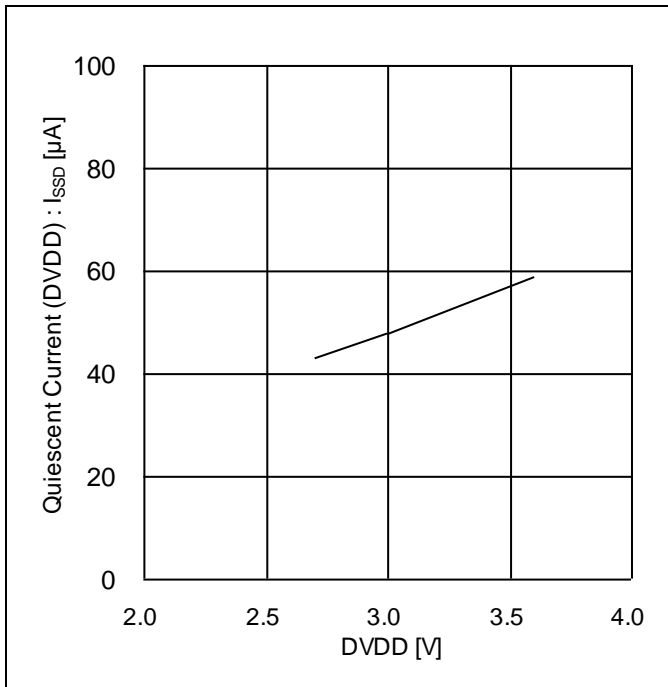

Figure 1. Quiescent Current (DVDD) vs DVDD

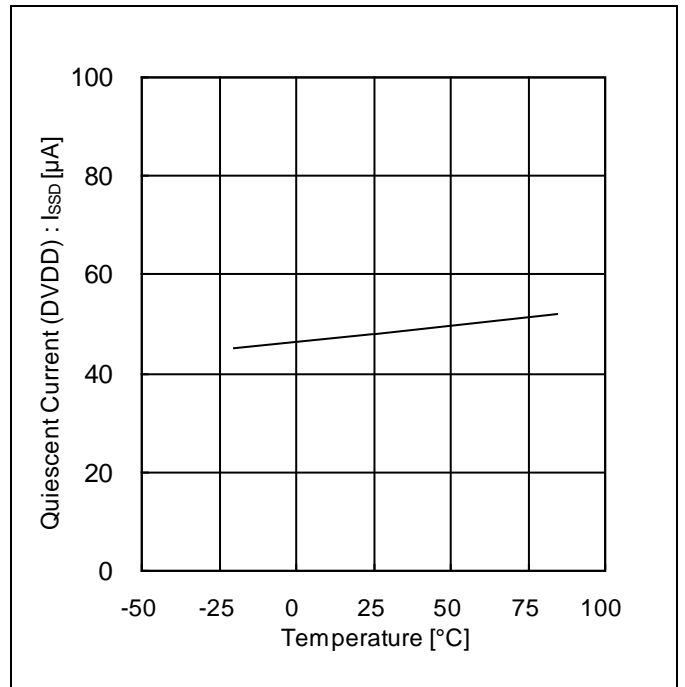

Figure 2. Quiescent Current (DVDD) vs Temperature

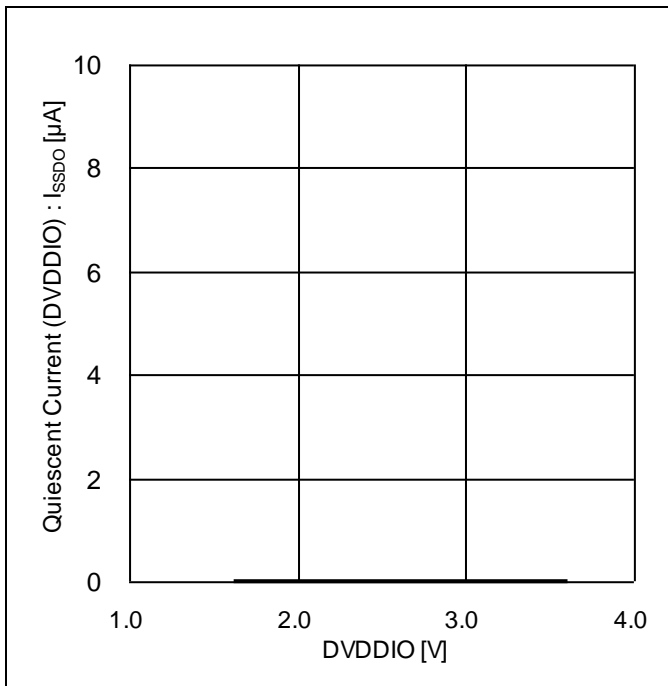

Figure 3. Quiescent Current (DVDDIO) vs DVDDIO

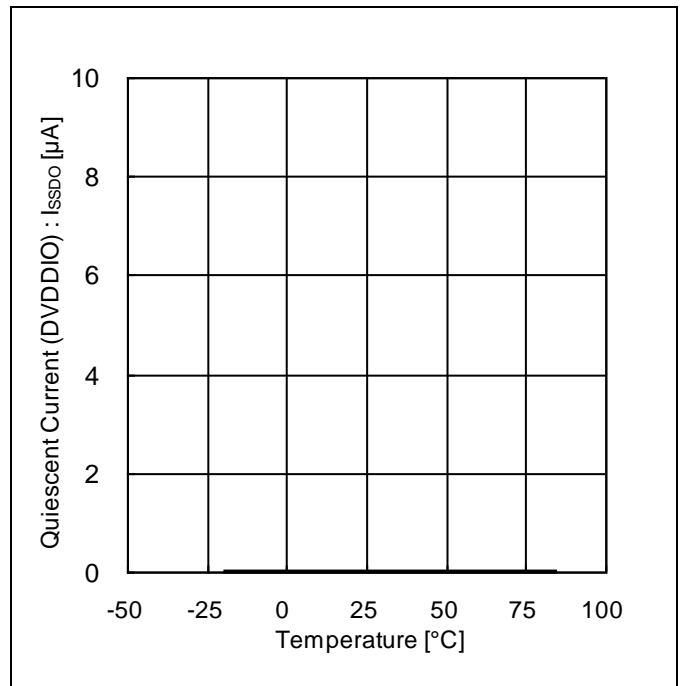

Figure 4. Quiescent Current (DVDDIO) vs Temperature

Typical Performance Curves – continued

(Unless otherwise specified  $T_a=25\text{ }^\circ\text{C}$ ,  $DVDDIO=DVDD=3.0\text{ V}$ ,  $MVCC12=MVCC34=VDDAMP=5.0\text{ V}$ )

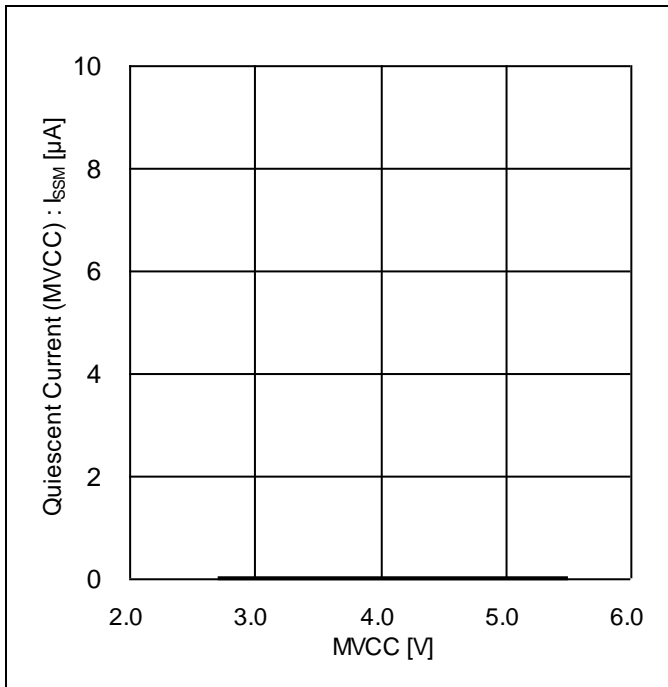

Figure 5. Quiescent Current (MVCC) vs MVCC

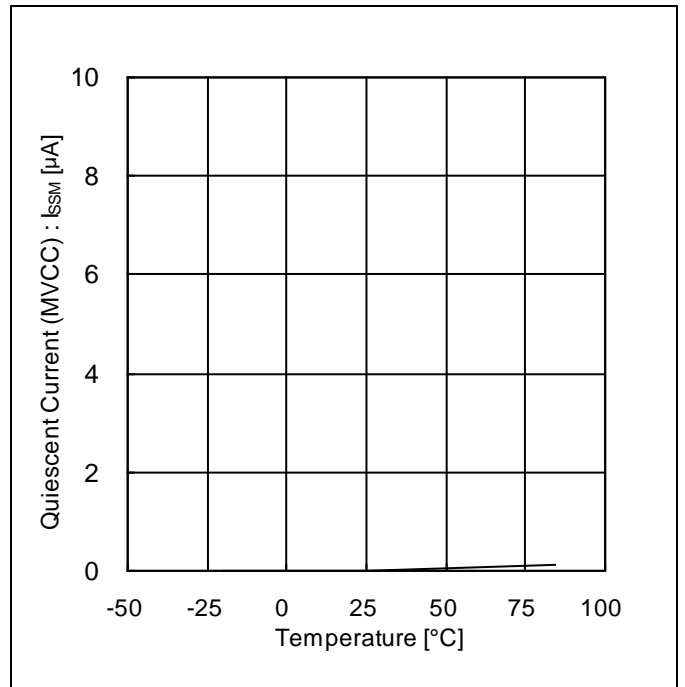

Figure 6. Quiescent Current (MVCC) vs Temperature

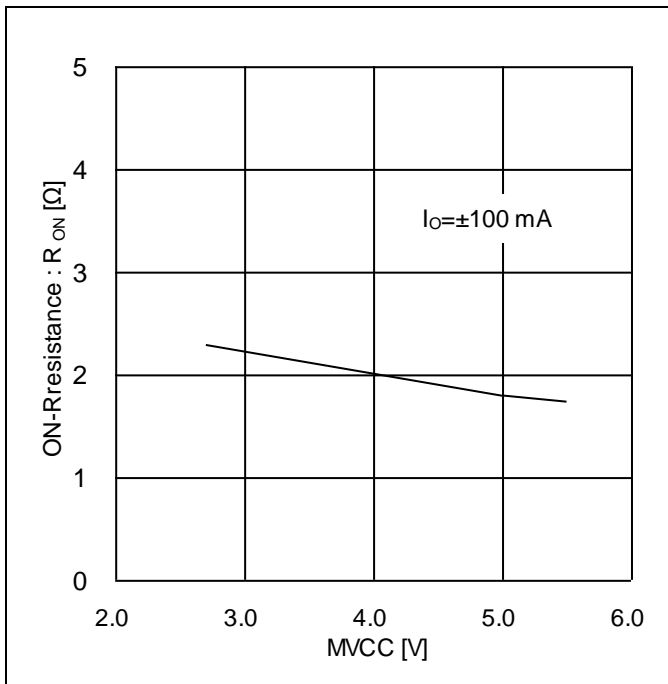

Figure 7. ON-Resistance vs MVCC (1ch, 2ch Driver Block)

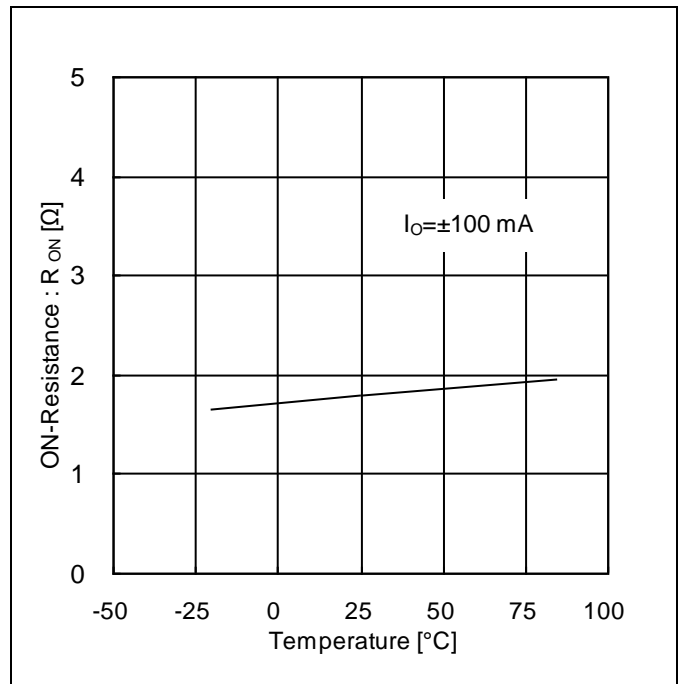

Figure 8. ON-Resistance vs Temperature (1ch, 2ch Driver Block)

Typical Performance Curves – continued

(Unless otherwise specified  $T_a=25\text{ }^\circ\text{C}$ ,  $DVDDIO=DVDD=3.0\text{ V}$ ,  $MVCC12=MVCC34=VDDAMP=5.0\text{ V}$ )

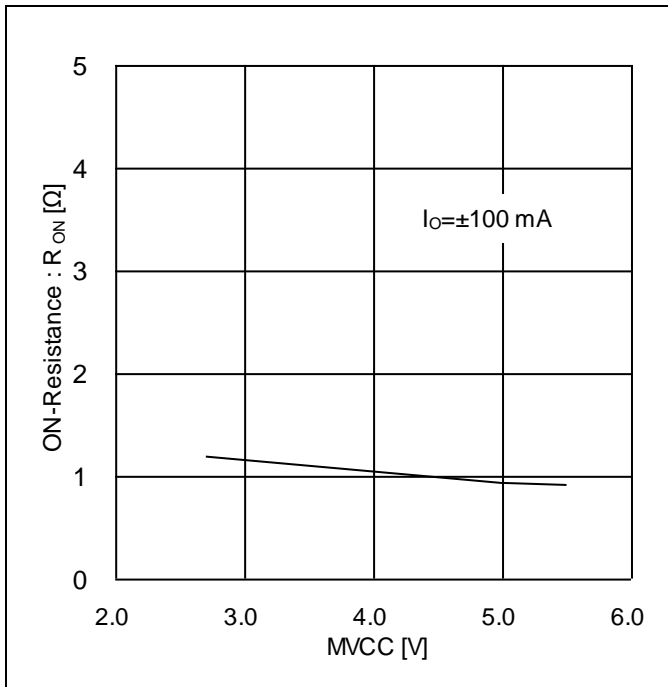

Figure 9. ON-Resistance vs MVCC (5ch, 6ch Driver Block)

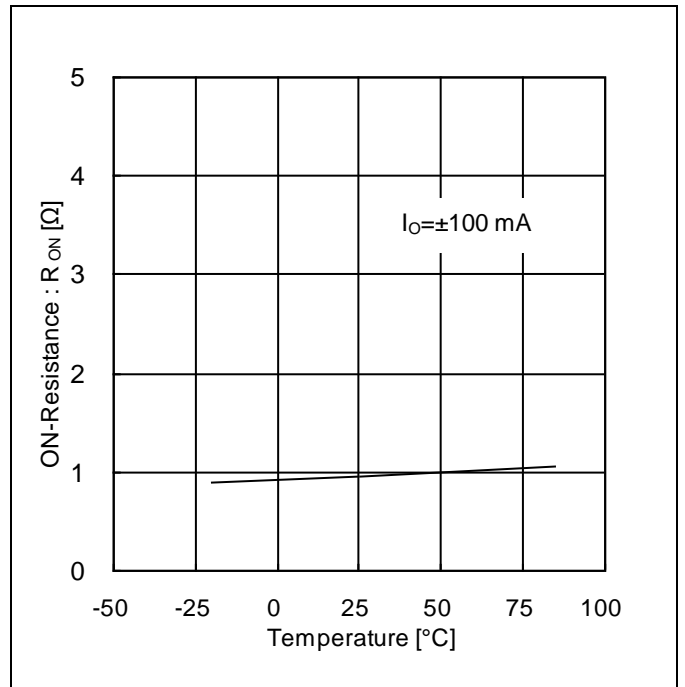

Figure 10. ON-Resistance vs Temperature (5ch, 6ch Driver Block)

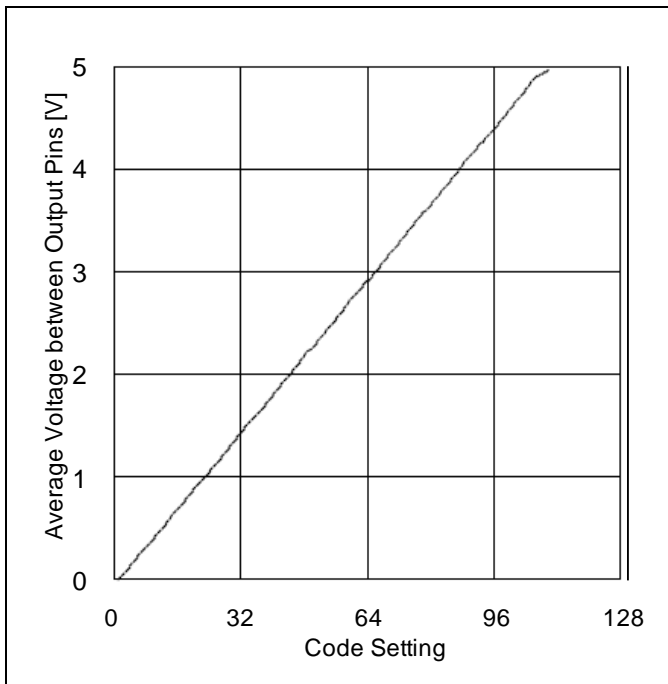

Figure 11. Average Voltage between Output Pins vs Code Setting (Voltage Driver Block)

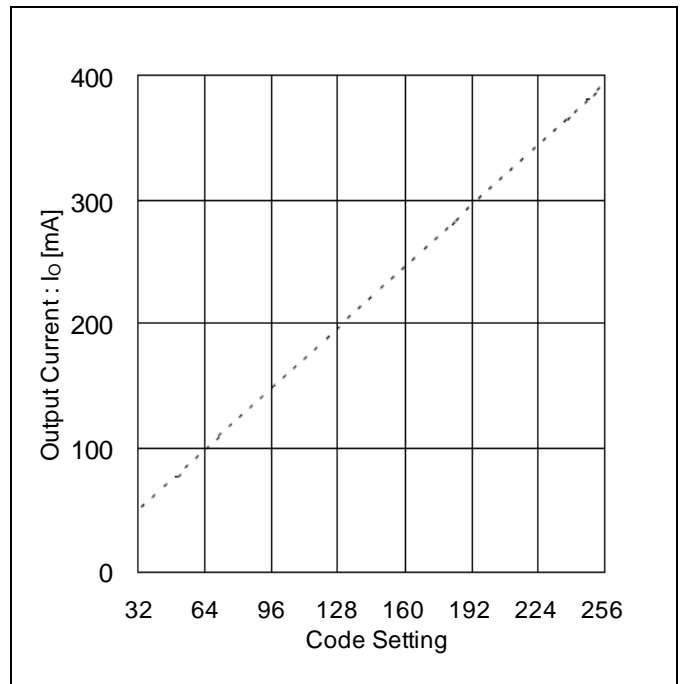

Figure 12. Output Current vs Code Setting (Current Driver Block,  $R_{RNF}=1.0\text{ }\Omega$ ,  $R_L=5.0\text{ }\Omega$ )

**Typical Performance Curves – continued**

(Unless otherwise specified  $T_a=25\text{ }^\circ\text{C}$ ,  $DVDDIO=DVDD=3.0\text{ V}$ ,  $MVCC12=MVCC34=VDDAMP=5.0\text{ V}$ )

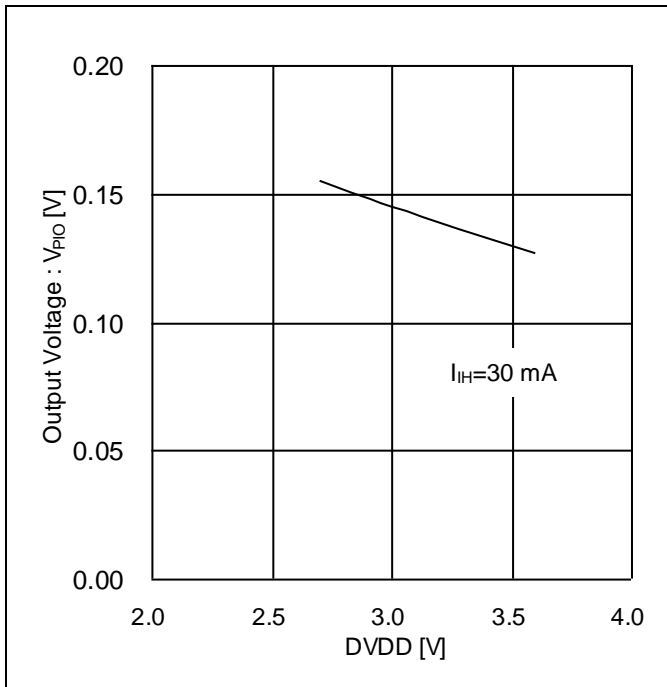
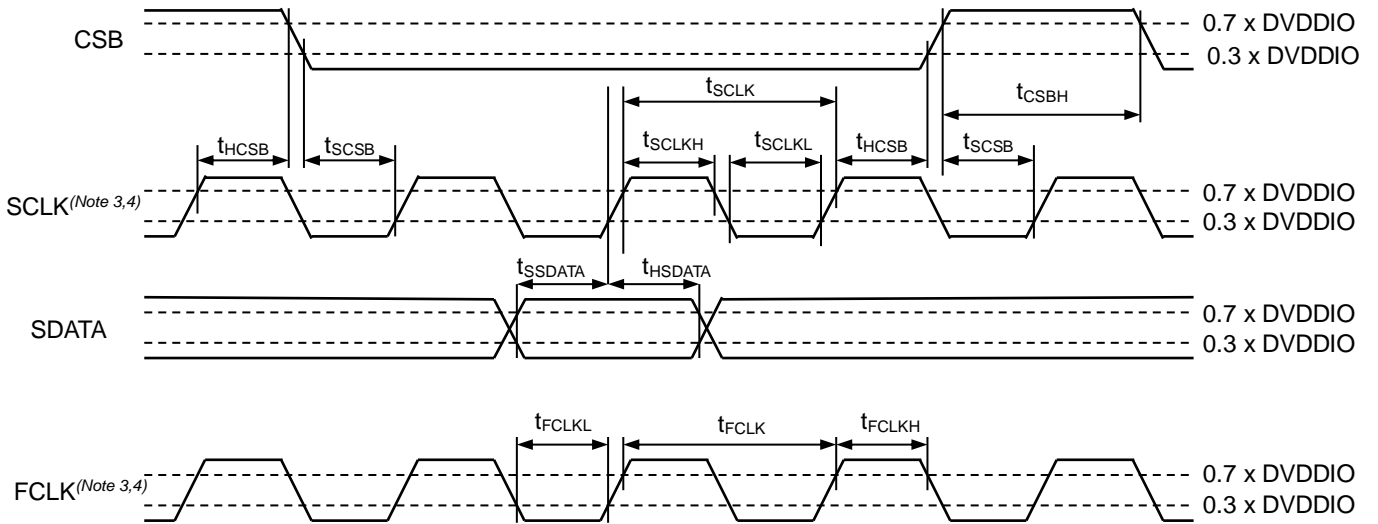

Figure 13. Output Voltage vs DVDD  
(PIOUIT1 Driver Circuit)

**Timing Chart**

(Unless otherwise specified, Ta=25 °C, DVDDIO=DVDD=3.0 V)

Parameter	Symbol	Design Value
SCLK Input Cycle	$t_{SCLK}$	100 ns or more
SCLK Low-Level Input Time	$t_{SCLKL}$	50 ns or more
SCLK High-Level Input Time	$t_{SCLKH}$	50 ns or more
SDATA Setup Time	$t_{SSDATA}$	50 ns or more
SDATA Hold Time	$t_{HSDATA}$	50 ns or more
CSB High-Level Input Time	$t_{CSBH}$	380 ns or more
CSB Setup Time	$t_{SCSB}$	50 ns or more
CSB Hold Time	$t_{HCSB}$	50 ns or more
FCLK Input Cycle	$t_{FCLK}$	36 ns or more
FCLK Low-Level Input Time	$t_{FCLKL}$	18 ns or more
FCLK High-Level Input Time	$t_{FCLKH}$	18 ns or more



(Note 3) FCLK is asynchronous with SCLK.

(Note 4) The duty of FCLK and SCLK is arbitrary after observing the above table.

**Serial interface**

Control command is 16-bit serial input (MSB first) and is sent via the CSB, the SCLK, and the SDATA pins. Higher 4 bits specify addresses and lower 12 bits specify data. Data of each bit is sent via the SDATA pin and taken at a rising edge of SCLK. The Data taken during CSB 'L' period is valid and is written in register at a rising edge of CSB.

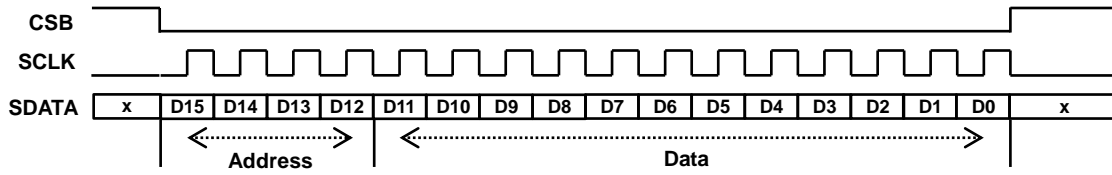

**Register Map**(Note 5,6,7)

Address[3:0]				Data[11:0]											
15	14	13	12	11	10	9	8	7	6	5	4	3	2	1	0
0	0	0	0	A_Mode[1:0]		A_SEL[2:0]		A_different_output_voltage[6:0]						0	0
0	0	0	1	0	0	0	0	A_Cycle[5:0]						0	0
				0	0	1	0	A_Cycle[13:6]						A_Start_POS[3:0]	
				0	1	0	0	0	0	0	0	0	A_Start_POS[3:0]		
				0	1	1	0	A_BEXC	0	0	A_BSL	A_AEXC	0	0	A_AS_L
				1	1	1	0	0	0	A_POS[1:0]		0	A_UPDW_Stop	A_PS	A_Stop
0	0	1	0	A_EN	A_RT	A_Pulse[9:0]/A_UPDW_Cycle[9:0]									
0	1	0	0	B_Mode[1:0]		B_SEL[2:0]		B_different_output_voltage[6:0]						0	0
0	1	0	1	0	0	0	0	B_Cycle[5:0]						0	0
				0	0	1	0	B_Cycle[13:6]						B_Start_POS[3:0]	
				0	1	0	0	0	0	0	0	B_Start_POS[3:0]			
				0	1	1	0	B_BEXC	0	0	B_BSL	B_AEXC	0	0	B_AS_L
				1	0	0	0	0	0	3_CHOP[1:0]		0	0	4_CHOP[1:0]	
				1	0	1	3_State_CTL[1:0]		3_PWM_Duty[6:0]						
				1	1	0	4_State_CTL[1:0]		4_PWM_Duty[6:0]						
1	1	1	0	0	0	B_POS[1:0]		0	B_UPDW_Stop	B_PS	B_Stop				
0	1	1	0	B_EN	B_RT	B_Pulse[9:0]/B_UPDW_Cycle[9:0]									
1	0	1	1	0	0	0	0	B_ANSEL	A_ANSEL	Edge	0	0	0	B_CTL	A_CTL
				0	0	1	0	0	0	0	0	0	EXT_CTL[1:0]		
1	1	0	0	0	0	Chopping[1:0]		CacheM	0	5_Mode	CLK_EN	CLK_DIV[3:0]			
1	1	0	1	0	0	0	0	0	0	0	0	0	0	PI_CTL2	PI_CTL1
				0	0	1	0	DET_SEL	0	SPEN[1:0]		0	0	0	0
				0	1	1	0	TARSP[7:0]							
				0	1	1	1	0	PSP[2:0]		0	ISP[2:0]			
				1	0	0	0	SPC_Limit_Out	0	0	0	SPC_Limit[3:0]			
1	1	1	0	0	0	0	0	5_IOUT[7:0]							
				0	0	1	0	0	5_PWM_Duty[6:0]						
				0	1	0	0	0	0	5_CHOP[1:0]		0	0	5_State_CTL[1:0]	
				0	1	1	0	0	0	0	0	6_State_CTL[2:0]			
				1	0	0	0	6_IOUT[7:0]							
				1	0	1	0	0	Waveform_Vthh[5:0]						
				1	0	1	1	0	Waveform_Vthl[5:0]						
				1	1	0	0	0	0	0	0	STB	0	0	STM_RS
Other than the above				Setting Prohibited											

(Note 5) The notations A and B in the register map correspond to Ach and Bch respectively. Ach is defined as 1ch and 2ch driver output, Bch as 3ch and 4ch driver output.

(Note 6) After power on reset, the initial settings are stored in all registers.

(Note 7) Regarding Mode, different\_output\_voltage, Cycle, EN, and RT registers, the data written right before the access to the Pulse register is valid and determined at a rising edge of CSB after the access to the Pulse register.

(The Mode, different\_output\_voltage, Cycle, EN, RT, and Pulse registers have Cache registers. Any registers other than them do not have Cache registers.)



Application Example

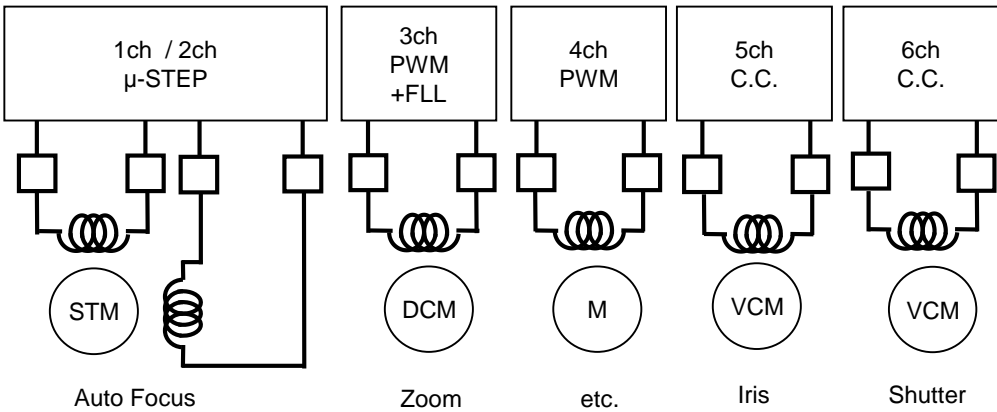
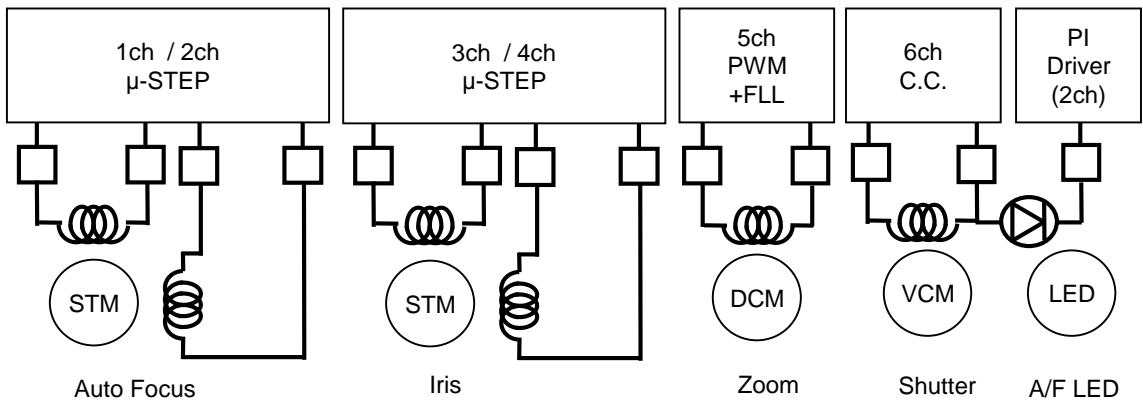
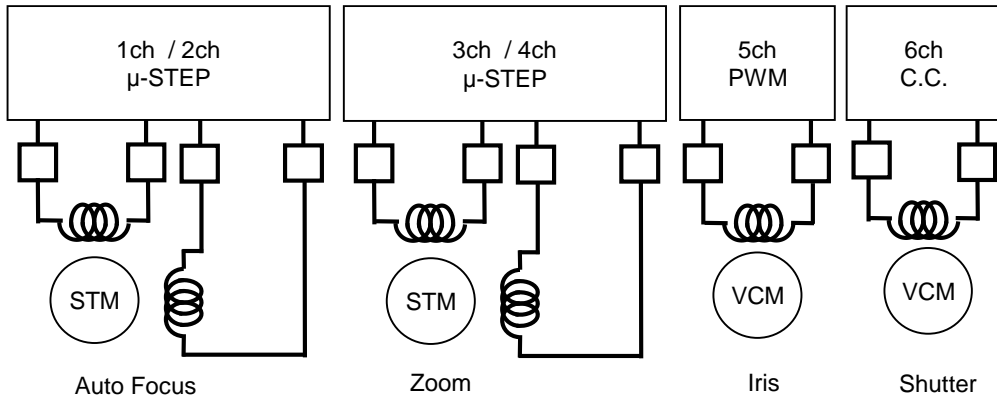

I/O Equivalence Circuit

Pin	Equivalent Circuit Diagram	Pin	Equivalent Circuit Diagram
FCLK CSB SCLK SDATA INA INB	<p>DVDDIO DVDDIO</p>	SI	<p>DVDD</p>
STATE11 STATE21	<p>DVDDIO DVDDIO</p>	STATE12 STATE22 SO	<p>DVDDIO DVDDIO</p>
PIOUT1	<p>DVDD</p>	PIOUT2	<p>VDDAMP</p>
OUT1A OUT1B OUT2A OUT2B	<p>MVCC12</p>	OUT3A OUT3B OUT4A OUT4B	<p>MVCC34</p>
OUT5A OUT5B	<p>RNF5</p>	OUT6A OUT6B	<p>RNF6</p>

I/O Equivalence Circuit - continued

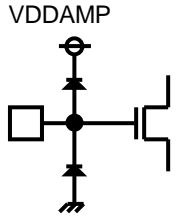
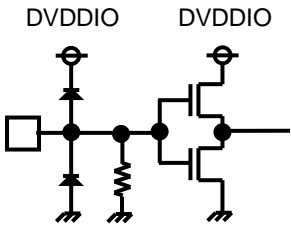
Pin	Equivalent Circuit Diagram	Pin	Equivalent Circuit Diagram
SENSE5 SENSE6		TEST <sup>(Note 8)</sup>	

(Note 8) Short the TEST pin to DVSS.

## Operational Notes

### 1. Reverse Connection of Power Supply

Connecting the power supply in reverse polarity can damage the IC. Take precautions against reverse polarity when connecting the power supply, such as mounting an external diode between the power supply and the IC's power supply pins.

### 2. Power Supply Lines

Design the PCB layout pattern to provide low impedance supply lines. Separate the ground and supply lines of the digital and analog blocks to prevent noise in the ground and supply lines of the digital block from affecting the analog block. Furthermore, connect a capacitor to ground at all power supply pins. Consider the effect of temperature and aging on the capacitance value when using electrolytic capacitors.

### 3. Ground Voltage

Ensure that no pins are at a voltage below that of the ground pin at any time, even during transient condition.

### 4. Ground Wiring Pattern

When using both small-signal and large-current ground traces, the two ground traces should be routed separately but connected to a single ground at the reference point of the application board to avoid fluctuations in the small-signal ground caused by large currents. Also ensure that the ground traces of external components do not cause variations on the ground voltage. The ground lines must be as short and thick as possible to reduce line impedance.

### 5. Recommended Operating Conditions

The function and operation of the IC are guaranteed within the range specified by the recommended operating conditions. The characteristic values are guaranteed only under the conditions of each item specified by the electrical characteristics.

### 6. Inrush Current

When power is first supplied to the IC, it is possible that the internal logic may be unstable and inrush current may flow instantaneously due to the internal powering sequence and delays, especially if the IC has more than one power supply. Therefore, give special consideration to power coupling capacitance, power wiring, width of ground wiring, and routing of connections.

### 7. Testing on Application Boards

When testing the IC on an application board, connecting a capacitor directly to a low-impedance output pin may subject the IC to stress. Always discharge capacitors completely after each process or step. The IC's power supply should always be turned off completely before connecting or removing it from the test setup during the inspection process. To prevent damage from static discharge, ground the IC during assembly and use similar precautions during transport and storage.

### 8. Inter-pin Short and Mounting Errors

Ensure that the direction and position are correct when mounting the IC on the PCB. Incorrect mounting may result in damaging the IC. Avoid nearby pins being shorted to each other especially to ground, power supply and output pin. Inter-pin shorts could be due to many reasons such as metal particles, water droplets (in very humid environment) and unintentional solder bridge deposited in between pins during assembly to name a few.

### 9. Unused Input Pins

Input pins of an IC are often connected to the gate of a MOS transistor. The gate has extremely high impedance and extremely low capacitance. If left unconnected, the electric field from the outside can easily charge it. The small charge acquired in this way is enough to produce a significant effect on the conduction through the transistor and cause unexpected operation of the IC. So unless otherwise specified, unused input pins should be connected to the power supply or ground line.

**Operational Notes – continued****10. Regarding the Input Pin of the IC**

In the construction of this IC, P-N junctions are inevitably formed creating parasitic diodes or transistors. The operation of these parasitic elements can result in mutual interference among circuits, operational faults, or physical damage. Therefore, conditions which cause these parasitic elements to operate, such as applying a voltage to an input pin lower than the ground voltage should be avoided. Furthermore, do not apply a voltage to the input pins when no power supply voltage is applied to the IC. Even if the power supply voltage is applied, make sure that the input pins have voltages within the values specified in the electrical characteristics of this IC.

**11. Ceramic Capacitor**

When using a ceramic capacitor, determine a capacitance value considering the change of capacitance with temperature and the decrease in nominal capacitance due to DC bias and others.

**12. Thermal Shutdown Circuit (TSD)**

This IC has a built-in thermal shutdown circuit that prevents heat damage to the IC. Normal operation should always be within the IC's maximum junction temperature rating. If however the rating is exceeded for a continued period, the junction temperature ( $T_j$ ) will rise which will activate the TSD circuit that will turn OFF power output pins. When the  $T_j$  falls below the TSD threshold, the circuits are automatically restored to normal operation.

Note that the TSD circuit operates in a situation that exceeds the absolute maximum ratings and therefore, under no circumstances, should the TSD circuit be used in a set design or for any purpose other than protecting the IC from heat damage.

Ordering Information

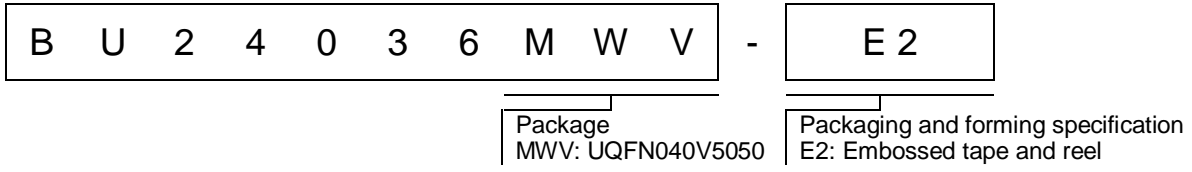

Marking Diagram

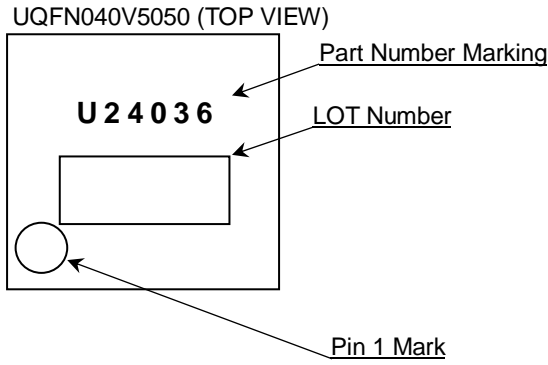

Physical Dimension and Packing Information

Package Name	UQFN040V5050
--------------	--------------

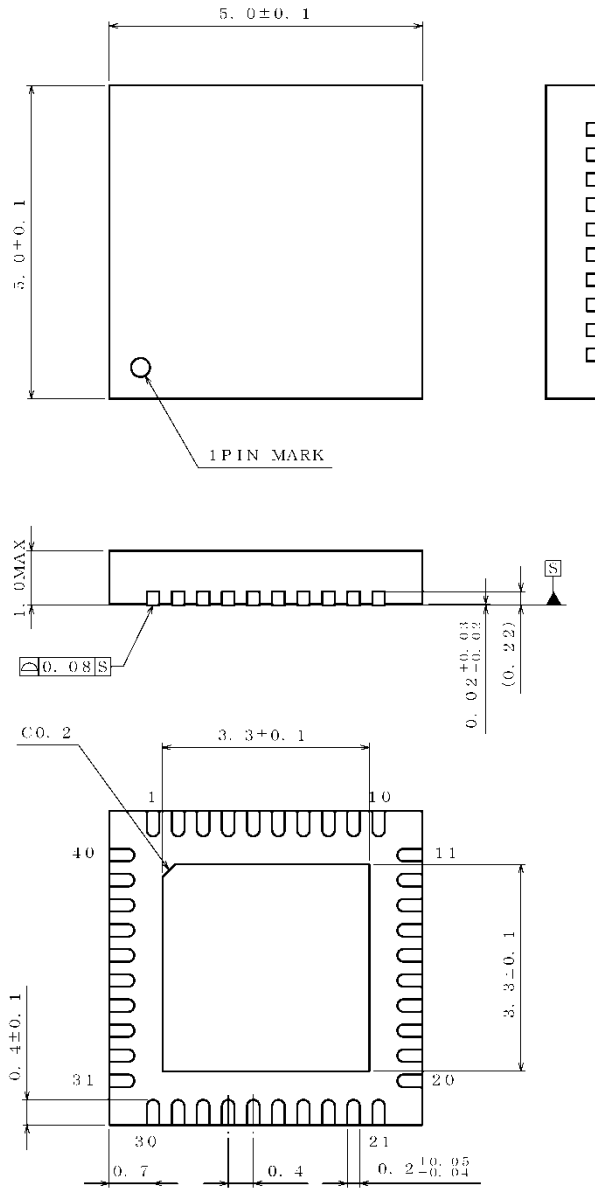

(UNIT : mm)

PKG : UQFN040V5050  
Drawing No. EX484 5001 2

<Tape and Reel information>

Tape	Embossed carrier tape
Quantity	2500pcs
Direction of feed	E2 (The direction is the 1pin of product is at the upper left when you hold reel on the left hand and you pull out the tape on the right hand)

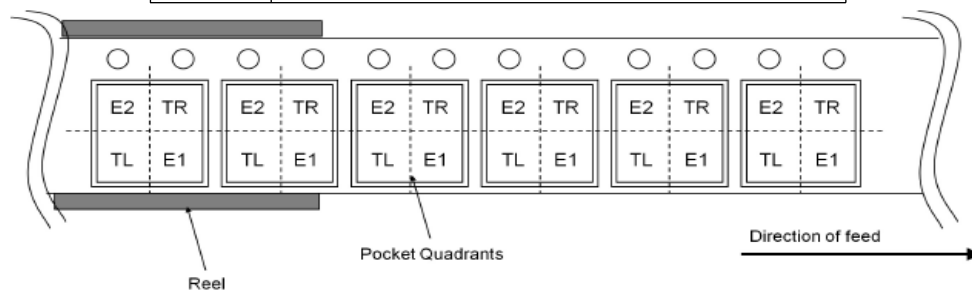

## Revision History

Date	Revision	Changes
10.Oct.2012	001	New Release
02.May.2013	002	Update some English words, sentences, descriptions, grammar and format.
20.May.2016	003	Correct comments of pin description.
12.Mar.2019	004	<p>In the "Typical Application Circuit" names of connected power supply are added.</p> <p>In the "Pin Configuration" and "Pin Description" the "EXP-PAD" which is located at the center of backside is added.</p> <p>In the "Absolute Maximum Ratings" the "Maximum Junction Temperature" is added.</p> <p>In the "Absolute Maximum Ratings" notes are added. e.g. About when operating the IC over the "Absolute Maximum Ratings",</p> <p>"Operating Temperature" is moved to "Recommended Operating Conditions" from "Absolute Maximum Ratings".</p> <p>In the "Typical Performance Curves" Quiescent Current (DVDDIO) graphs are added.</p> <p>In the "Typical Performance Curves" package power dissipation graph is removed, because it's same information as Note 2 in "Absolute Maximum Ratings".</p> <p>"Operational Notes" are updated.</p> <p>Other formats are updated.</p>



# Notice

## Precaution on using ROHM Products

- Our Products are designed and manufactured for application in ordinary electronic equipment (such as AV equipment, OA equipment, telecommunication equipment, home electronic appliances, amusement equipment, etc.). If you intend to use our Products in devices requiring extremely high reliability (such as medical equipment <sup>(Note 1)</sup>, transport equipment, traffic equipment, aircraft/spacecraft, nuclear power controllers, fuel controllers, car equipment including car accessories, safety devices, etc.) and whose malfunction or failure may cause loss of human life, bodily injury or serious damage to property ("Specific Applications"), please consult with the ROHM sales representative in advance. Unless otherwise agreed in writing by ROHM in advance, ROHM shall not be in any way responsible or liable for any damages, expenses or losses incurred by you or third parties arising from the use of any ROHM's Products for Specific Applications.

(Note1) Medical Equipment Classification of the Specific Applications

JAPAN	USA	EU	CHINA
CLASS III	CLASS III	CLASS II b	CLASS III
CLASS IV		CLASS III	

- ROHM designs and manufactures its Products subject to strict quality control system. However, semiconductor products can fail or malfunction at a certain rate. Please be sure to implement, at your own responsibilities, adequate safety measures including but not limited to fail-safe design against the physical injury, damage to any property, which a failure or malfunction of our Products may cause. The following are examples of safety measures:
  - Installation of protection circuits or other protective devices to improve system safety
  - Installation of redundant circuits to reduce the impact of single or multiple circuit failure
- Our Products are designed and manufactured for use under standard conditions and not under any special or extraordinary environments or conditions, as exemplified below. Accordingly, ROHM shall not be in any way responsible or liable for any damages, expenses or losses arising from the use of any ROHM's Products under any special or extraordinary environments or conditions. If you intend to use our Products under any special or extraordinary environments or conditions (as exemplified below), your independent verification and confirmation of product performance, reliability, etc. prior to use, must be necessary:
  - Use of our Products in any types of liquid, including water, oils, chemicals, and organic solvents
  - Use of our Products outdoors or in places where the Products are exposed to direct sunlight or dust
  - Use of our Products in places where the Products are exposed to sea wind or corrosive gases, including Cl<sub>2</sub>, H<sub>2</sub>S, NH<sub>3</sub>, SO<sub>2</sub>, and NO<sub>2</sub>
  - Use of our Products in places where the Products are exposed to static electricity or electromagnetic waves
  - Use of our Products in proximity to heat-producing components, plastic cords, or other flammable items
  - Sealing or coating our Products with resin or other coating materials
  - Use of our Products without cleaning residue of flux (Exclude cases where no-clean type fluxes is used. However, recommend sufficiently about the residue.) ; or Washing our Products by using water or water-soluble cleaning agents for cleaning residue after soldering
  - Use of the Products in places subject to dew condensation
- The Products are not subject to radiation-proof design.
- Please verify and confirm characteristics of the final or mounted products in using the Products.
- In particular, if a transient load (a large amount of load applied in a short period of time, such as pulse, is applied, confirmation of performance characteristics after on-board mounting is strongly recommended. Avoid applying power exceeding normal rated power; exceeding the power rating under steady-state loading condition may negatively affect product performance and reliability.
- De-rate Power Dissipation depending on ambient temperature. When used in sealed area, confirm that it is the use in the range that does not exceed the maximum junction temperature.
- Confirm that operation temperature is within the specified range described in the product specification.
- ROHM shall not be in any way responsible or liable for failure induced under deviant condition from what is defined in this document.

## Precaution for Mounting / Circuit board design

- When a highly active halogenous (chlorine, bromine, etc.) flux is used, the residue of flux may negatively affect product performance and reliability.
- In principle, the reflow soldering method must be used on a surface-mount products, the flow soldering method must be used on a through hole mount products. If the flow soldering method is preferred on a surface-mount products, please consult with the ROHM representative in advance.

For details, please refer to ROHM Mounting specification

### Precautions Regarding Application Examples and External Circuits

1. If change is made to the constant of an external circuit, please allow a sufficient margin considering variations of the characteristics of the Products and external components, including transient characteristics, as well as static characteristics.
2. You agree that application notes, reference designs, and associated data and information contained in this document are presented only as guidance for Products use. Therefore, in case you use such information, you are solely responsible for it and you must exercise your own independent verification and judgment in the use of such information contained in this document. ROHM shall not be in any way responsible or liable for any damages, expenses or losses incurred by you or third parties arising from the use of such information.

### Precaution for Electrostatic

This Product is electrostatic sensitive product, which may be damaged due to electrostatic discharge. Please take proper caution in your manufacturing process and storage so that voltage exceeding the Products maximum rating will not be applied to Products. Please take special care under dry condition (e.g. Grounding of human body / equipment / solder iron, isolation from charged objects, setting of Ionizer, friction prevention and temperature / humidity control).

### Precaution for Storage / Transportation

1. Product performance and soldered connections may deteriorate if the Products are stored in the places where:
  - [a] the Products are exposed to sea winds or corrosive gases, including Cl<sub>2</sub>, H<sub>2</sub>S, NH<sub>3</sub>, SO<sub>2</sub>, and NO<sub>2</sub>
  - [b] the temperature or humidity exceeds those recommended by ROHM
  - [c] the Products are exposed to direct sunshine or condensation
  - [d] the Products are exposed to high Electrostatic
2. Even under ROHM recommended storage condition, solderability of products out of recommended storage time period may be degraded. It is strongly recommended to confirm solderability before using Products of which storage time is exceeding the recommended storage time period.
3. Store / transport cartons in the correct direction, which is indicated on a carton with a symbol. Otherwise bent leads may occur due to excessive stress applied when dropping of a carton.
4. Use Products within the specified time after opening a humidity barrier bag. Baking is required before using Products of which storage time is exceeding the recommended storage time period.

### Precaution for Product Label

A two-dimensional barcode printed on ROHM Products label is for ROHM's internal use only.

### Precaution for Disposition

When disposing Products please dispose them properly using an authorized industry waste company.

### Precaution for Foreign Exchange and Foreign Trade act

Since concerned goods might be fallen under listed items of export control prescribed by Foreign exchange and Foreign trade act, please consult with ROHM in case of export.

### Precaution Regarding Intellectual Property Rights

1. All information and data including but not limited to application example contained in this document is for reference only. ROHM does not warrant that foregoing information or data will not infringe any intellectual property rights or any other rights of any third party regarding such information or data.
2. ROHM shall not have any obligations where the claims, actions or demands arising from the combination of the Products with other articles such as components, circuits, systems or external equipment (including software).
3. No license, expressly or implied, is granted hereby under any intellectual property rights or other rights of ROHM or any third parties with respect to the Products or the information contained in this document. Provided, however, that ROHM will not assert its intellectual property rights or other rights against you or your customers to the extent necessary to manufacture or sell products containing the Products, subject to the terms and conditions herein.

### Other Precaution

1. This document may not be reprinted or reproduced, in whole or in part, without prior written consent of ROHM.
2. The Products may not be disassembled, converted, modified, reproduced or otherwise changed without prior written consent of ROHM.
3. In no event shall you use in any way whatsoever the Products and the related technical information contained in the Products or this document for any military purposes, including but not limited to, the development of mass-destruction weapons.
4. The proper names of companies or products described in this document are trademarks or registered trademarks of ROHM, its affiliated companies or third parties.

**General Precaution**

1. Before you use our Products, you are requested to carefully read this document and fully understand its contents. ROHM shall not be in any way responsible or liable for failure, malfunction or accident arising from the use of any ROHM's Products against warning, caution or note contained in this document.
2. All information contained in this document is current as of the issuing date and subject to change without any prior notice. Before purchasing or using ROHM's Products, please confirm the latest information with a ROHM sales representative.
3. The information contained in this document is provided on an "as is" basis and ROHM does not warrant that all information contained in this document is accurate and/or error-free. ROHM shall not be in any way responsible or liable for any damages, expenses or losses incurred by you or third parties resulting from inaccuracy or errors of or concerning such information.