

- 1
- 2
- 3
- 4
- 5
- 6
- 7
- 8
- 9
- 10
- 11
- 12
- 13
- 14
- 15
- 16
- 17
- 18

MATERIAL

Anodised aluminium black colour.

INDEX

White laser-engraved line.

STANDARD EXECUTION

H8 reamed hole.

Assembly by means of a supplied stainless steel transversal grub screw with hexagon socket.

FEATURES AND APPLICATIONS

The two special flat faces of GN 729 control knobs allow a safe and comfortable grip. For this reason the knobs are usually used for applications which require a rotation within a 180° angle.

MANOEUVRE ANGLE LIMITATION

A limited manoeuvre angle is possible by fitting stop pins in the rear guide slot.

ACCESSORIES ON REQUEST

For clicking operation, we suggest to use smooth ball spring plungers GN 614 (see page 840) into d1 bore.

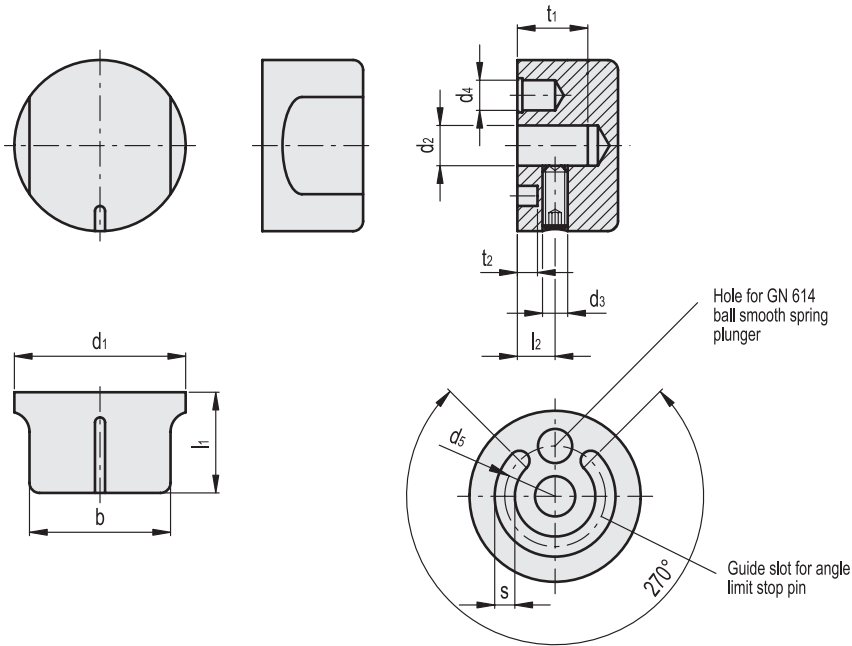

Code	Description	d1	d2 H8	d3	s+0,3+0.1	d4	d5	l1	l2	b	tmin	t2 +0.2	△
GN.30811	GN 729-34-B6	34	6	M5	4	6	20	20	7.5	28	14	4	45
GN.30821	GN 729-42-B8	42	8	M5	4	6	30	22	7.5	35	16	4	72