

DURAKOOL

Solid State Relays & Contactors

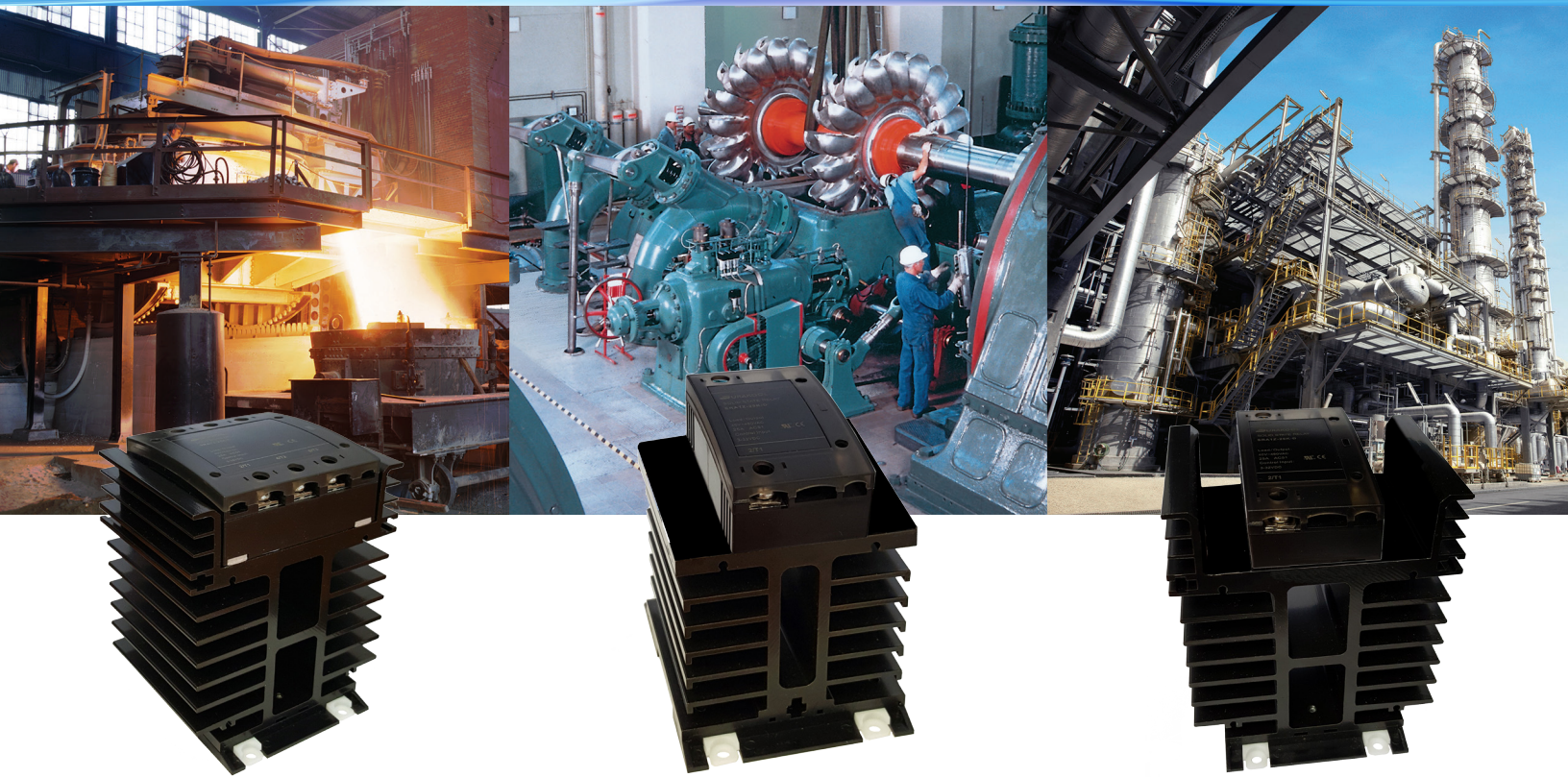

sales@accsensors.com



About American Electronics Components Incorporated

AEC founded as Durakool in 1935 is a leader in the design and manufacture of specialized highly engineered electrical and electronic components, primarily for automotive and industrial applications. Our product line includes position sensors, G-force sensors, acceleration switches, **Durakool** relays, push button switches, inclination sensors & switches and **HermaSeal** glass to metal seals. Our creative engineering team has extensive experience in harsh environmental packaging concepts. We use high-quality products and are positioned to support your most challenging applications.

The automotive, transportation, robot arm and industrial markets rely on AEC for sophisticated low-cost sensors and controls that enhance the safety and performance of their products. Through our disciplined approach, we have earned an excellent reputation for our technical innovation, agility, rapid response and high reliability. The AEC team has a "CAN DO" attitude and is ready to tackle your most challenging applications.

Please contact our Engineering Team at AEC, or your local Distributor, for further information and non standard items within our extensive product range.

To view Solid State Relay and Contactor information on-line please visit <http://www.aecensors.com/html/vmchk/Solid-State-Relays/View-all-products.html>. For in depth information and datasheets on our full product range, please visit our website www.aecensors.com.

Controlling electricity for over 80 years!

American Electronic Components and Durakool

- ▲ Global production facilities
- ▲ Extensive product portfolio
- ▲ Reputation for high reliability
- ▲ ISO9001:2008 & ISO14001:2004 Registered

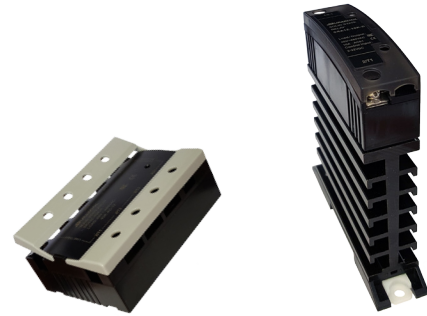

Index of Contents

Index of Contents		Page
AEC & Durakool	Company information	1
Index	Catalog contents	2
SRA1 series	Single phase solid-state relays	3
SRA3 series	Three phase solid-state relays	4
SRA2 series	Dual solid-state relays	5
SDA1 - 10 - 15	DIN rail 10A, 15A solid-state relays	6
SDA1 - 20 - 25 - 30	DIN rail 20A, 25A, 30A solid-state relays	7
SDA1 - 40	DIN rail 40A solid-state relays	8
SDA1 - 60 - 80	DIN rail 60 & 80A solid-state relays	9
SDB1 - 60 - 80	DIN rail 60 & 80A solid-state relays	10
SDA3 - 10 - 15	DIN rail 10 & 15A solid-state contactors	11
SDA3 - 20 - 25 - 30	DIN rail 20, 25 & 30A solid-state contactors	12
SDA3 - 40	DIN rail 40A solid-state contactors	13
SSG1C series	High power solid-state relays	14
Heat sinks	Solid-state relays - single phase	15
Heat sinks	Solid-state relays - three phase	16
Solid-state relays & contactors	General data and application notes	17
Solid-state relays & contactors	General data and application notes	18



- High load voltage - up to 480VAC.
- 4 - 32VDC or 90 - 250VAC control voltage.
- Zero cross-over or Random switching.
- LED control input indicator.
- Captive finger protection covers for terminals.
- Compatible heat sinks on Page 16



ROHS Compliant

Ordering Code

S R A 1 Z - 25 L - A

Switch Function

Z	-	Zero Crossover
R	-	Random

Load Current Rating

10	-	10A
20	-	20A
25	-	25A
30	-	30A
40	-	40A
60	-	60A
80	-	80A

Load Voltage

K	-	40 to 480VAC
L	-	24 to 240VAC

Control Voltage Input

A	-	90 to 250VAC
D	-	4 to 32VDC

Output (load)

Load type	SPST-NO (1 N/O) Resistive	
Load current	10A, 20A, 25A, 30A, 40A, 60A or 80A	
Load switching voltage	AC V_{rms}	24 ~ 240V, 40 ~ 480V
Maximum peak voltage	AC V_{pk}	900V
Minimum load current	0.1A	
Inrush Current (max.)	10ms	20A: 240A / 25A: 300A / 30A: 380A
I^2t	A^2s	20A: 288 / 25A: 450 / 30A: 660 / 40A: 880 / 60A:
		60A: 2100 / 80A: 4050
Switch type	Zero Cross (consult factory for Random)	

Input (control)

Control voltage	V	DC: 4 ~ 32 or AC: 90 ~ 250
Control current	mA	<20
Turn-on voltage (min)	V_{min}	DC: 3.5 / AC: 90V
Turn-on voltage (max)	V_{max}	DC: 35 / AC: 250V
Turn-off voltage	V	DC: 1 / AC: 10

General Data

Dimensions	L x W x H	60 x 45 x 27.5mm
Weight		98g

Schematics

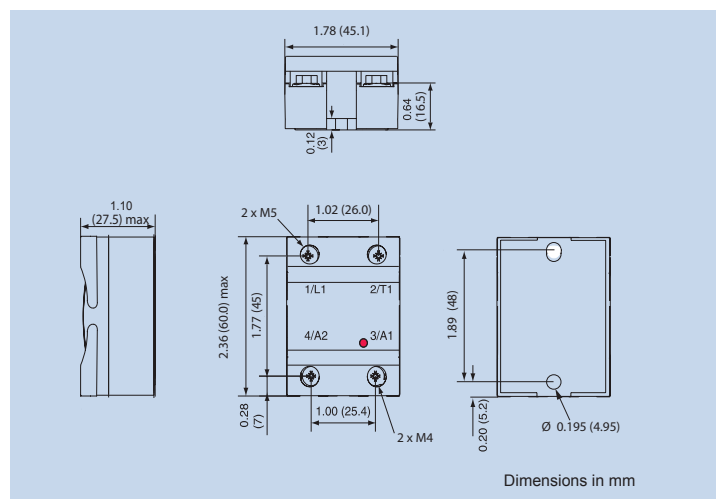
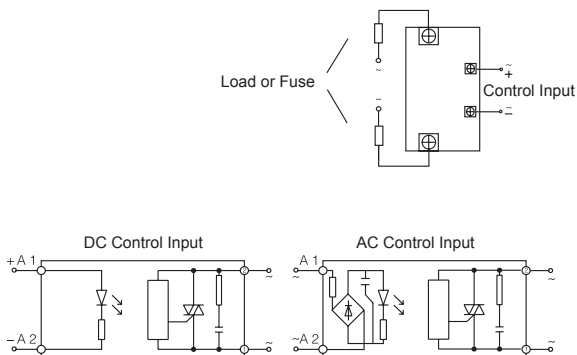

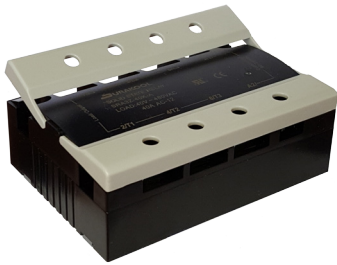

- High load voltage - up to 480VAC.
- 4 - 32VDC or 90 - 250VAC control voltage.
- Zero cross-over or Random switching.
- LED control input indicator.
- Captive finger protection covers for terminals.
- Compatible heat sinks on Page 17



ROHS Compliant

Ordering Code

S R A 3 Z - 25 K - D

Switch Function

Z	-	Zero Crossover
R	-	Random

Load Current Rating

10	-	10A
20	-	20A
25	-	25A
30	-	30A
40	-	40A
60	-	60A
80	-	80A

Load Voltage

K	-	40 to 480VAC
L	-	24 to 240VAC

Control Voltage Input

A	-	90 to 250VAC
D	-	4 to 32VDC

Output (load)

Load type		3PST-NO (3 N/O) Resistive
Load current		10A, 20A, 25A, 30A, 40A, 60A or 80A
Load switching voltage	AC V_{rms}	24 ~ 240V, 40 ~ 480V
Maximum peak voltage	AC V_{pk}	900V
Minimum load current		0.1A
Inrush Current (max.)	10ms	20A: 240A / 25A: 300A / 30A: 380A
I^2t	A^2s	20A: 288 / 25A: 450 / 30A: 660 / 40A: 880 / 60A:
		60A: 2100 / 80A: 4050
Switch type		Zero Cross (consult factory for Random)

Input (control)

Control voltage	V	DC: 4 ~ 32 or AC: 90 ~ 250
Control current	mA	<20
Turn-on voltage (min)	V_{min}	DC: 3.5 / AC: 90
Turn-on voltage (max)	V_{max}	DC: 35 / AC: 250
Turn-off voltage	V	DC: 1 / AC: 10

General Data

Dimensions	L x W x H	106 x 75 x 38mm
Weight		various 365g (10A) ~ 500g (80A)

Schematics

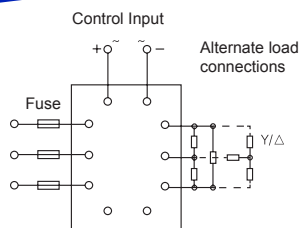

DC Control Input

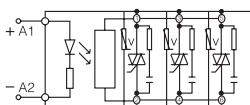

AC Control Input

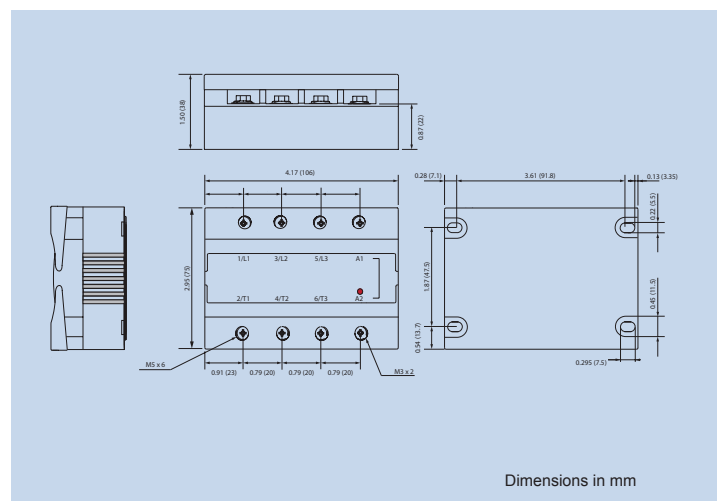
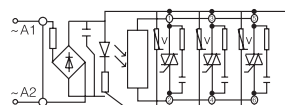



- High load voltage - up to 480VAC.
- 4 ~ 32VDC control input voltage.
- Single Phase, Zero cross-over switching.
- LED control input indicator.
- Integrated heatsink.
- DIN rail or chassis mounting.



ROHS Compliant

Ordering Code

S D A 1 Z - 10 K - D

Switch Function

Z	-	Zero Crossover
R	-	Random

Load Current Rating

10	-	10A
15	-	15A

Load Voltage

K	-	40 to 480VAC
---	---	--------------

Control Voltage Input

D	-	4 to 32VDC
---	---	------------

Output (load)

Load type		SPST-NO (1 N/O) Resistive
Load current		10A, 15A
Load switching voltage	AC V_{rms}	40 ~ 480V
Maximum peak voltage	AC V_{pk}	900V
Minimum load current		0.1A
Inrush Current (max.)	10ms	10A: 120A / 15A: 160A
I^2t		10A: 72A ² s / 15A: 128A ² s
Switch type		Zero Cross (Consult factory for Random)

Input (control)

Control voltage	V DC	4 ~ 32
Control current	mA	< 20mA
Turn-on voltage (min)	V DC _{min}	3.5
Turn-on voltage (max)	V DC _{max}	35
Turn-off voltage	V DC	2

General Data

Dimensions	L x W x H	100 x 24 x 107mm
Weight		approx. 228g

Schematics

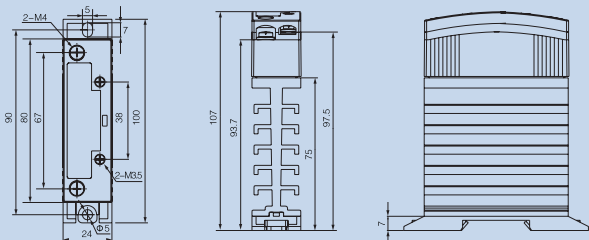
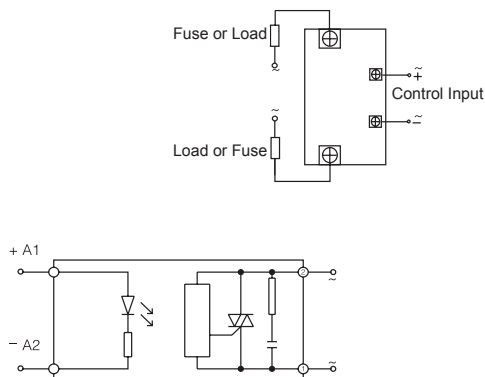

Dimensions in mm



- High load voltage - up to 480VAC
- 4 ~ 32VDC or 90 ~ 250VAC control voltage
- Single Phase, Zero cross-over switching
- LED control input indicator
- Integrated heatsink
- DIN rail or chassis mounting



ROHS Compliant

Ordering Code

S D A 1 Z - 25 K - A

Switch Function

Z	-	Zero Crossover
R	-	Random

Load Current Rating

20	-	20A
25	-	25A
30	-	30A

Load Voltage

K	-	40 to 480VAC
---	---	--------------

Control Voltage Input

A	-	90 to 250VAC
D	-	4 to 32VDC

Output (load)

Load type		SPST-NO (1 N/O) Resistive
Load current		20A, 25A, 30A
Load switching voltage	AC V_{rms}	40 ~ 480V
Maximum peak voltage	AC V_{pk}	900V
Minimum load current		0.1A
Inrush Current (max.)	10ms	20A: 240A / 25A: 300A / 30A: 380A
I^2t	A^2s	20A: 288 / 25A: 450 / 30A: 660
Switch type		Zero Cross (Consult factory for Random)

Input (control)

Control voltage	V	DC: 4 ~ 32DC / AC: 90 ~ 250AC
Control current	mA	< 20mA
Turn-on voltage (min)	V_{min}	DC: 3.5VDC / AC: 80VAC
Turn-on voltage (max)	V_{max}	DC: 35VDC / AC: 280VAC
Turn-off voltage	V	DC: 2VDC / AC: 40VAC

General Data

Dimensions	L x W x H	100 x 48 x 107mm
Weight		approx. 440g

Schematics

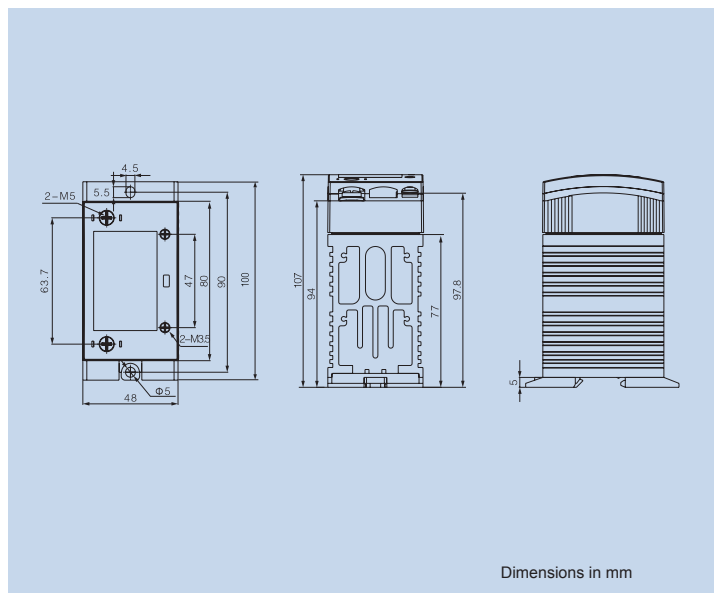
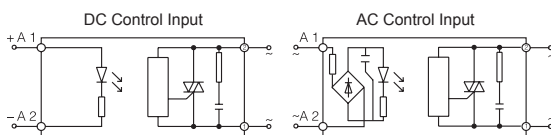
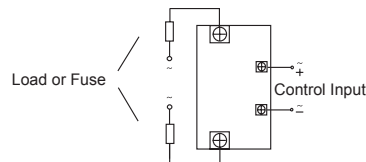

Dimensions in mm



- High load voltage - up to 480VAC.
- 4 ~ 32VDC or 90 ~ 250VAC control voltage.
- Single Phase, Zero cross-over switching.
- LED control input indicator.
- Integrated heatsink.
- DIN rail or chassis mounting.



ROHS Compliant

Ordering Code

S D A 1 Z - 40 K - D

Switch Function

Z	-	Zero Crossover
R	-	Random

Load Current Rating

40	-	40A
----	---	-----

Load Voltage

K	-	40 to 480VAC
---	---	--------------

Control Voltage Input

A	-	90 to 250VAC
D	-	4 to 32VDC

Output (load)

Load type	SPST-NO (1 N/O) Resistive	
Load current	40A	
Load switching voltage	AC V_{rms}	40 ~ 480V
Maximum peak voltage	AC V_{pk}	900V
Minimum load current	0.1A	
Inrush Current (max.)	10ms	450A
I^2t	A^2s	880
Switch type	Zero Cross (Consult factory for Random)	

Input (control)

Control voltage	V	DC: 4 ~ 32DC / AC: 90 ~ 250AC
Control current	mA	< 20mA
Turn-on voltage (min)	V_{min}	DC: 3.5VDC / AC: 80VAC
Turn-on voltage (max)	V_{max}	DC: 35VDC / AC: 280VAC
Turn-off voltage	V	DC: 2VDC / AC: 40VAC

General Data

Dimensions	L x W x H	100 x 80 x 107mm
Weight		approx. 940g

Schematics

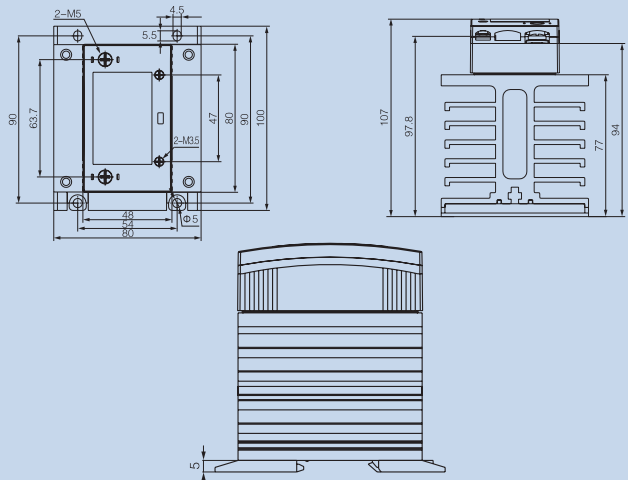
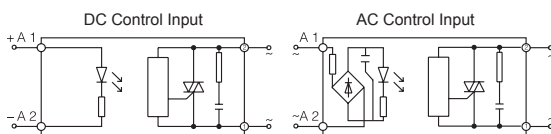
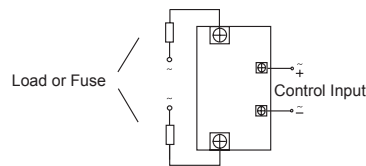

Dimensions in mm



- High load voltage - up to 480VAC.
- 4 ~ 32VDC or 90 ~ 250VAC control voltage.
- Single Phase, Zero cross-over switching.
- LED control input indicator.
- Integrated heatsink.
- DIN rail or chassis mounting.



ROHS Compliant

Ordering Code

S D A 1 Z - 60 K - D

Switch Function

Z	-	Zero Crossover
R	-	Random

Load Current Rating

60	-	60A
80	-	80A

Load Voltage

K	-	40 to 480VAC
---	---	--------------

Control Voltage Input

A	-	90 to 250VAC
D	-	4 to 32VDC

Output (load)

Load type	SPST-NO (1 N/O) Resistive	
Load current	60A, 80A	
Load switching voltage	AC V_{rms}	40 ~ 480V
Maximum peak voltage	AC V_{pk}	900V
Minimum load current	0.1A	
Inrush Current (max.)	10ms	60A: 650A / 80A: 900A
I^2t	A^2s	60A: 2100 / 80A: 4050
Switch type	Zero Cross (Consult factory for Random)	

Input (control)

Control voltage	V	DC: 4 ~ 32DC / AC: 90 ~ 250AC
Control current	mA	< 20mA
Turn-on voltage (min)	V_{min}	DC: 3.5VDC / AC: 80VAC
Turn-on voltage (max)	V_{max}	DC: 35VDC / AC: 280VAC
Turn-off voltage	V	DC: 2VDC / AC: 40VAC

General Data

Dimensions	L x W x H	100 x 110 x 127mm
Weight		approx. 940g

Schematics

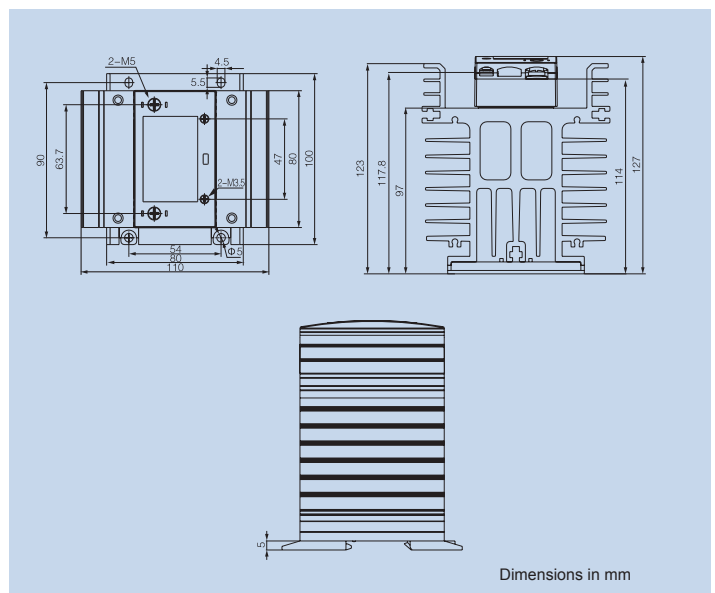
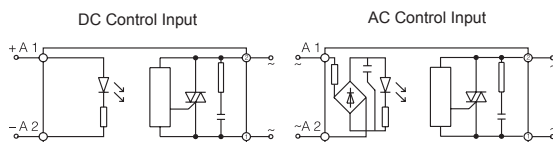
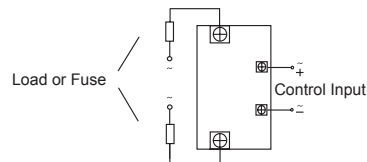

Dimensions in mm



- Enhanced load voltage - up to 660VAC with high power dual SCR output.
- 4 ~ 32VDC or 90 ~ 250VAC control voltage.
- Single Phase, Zero cross-over switching.
- LED control input indicator.
- Integrated heatsink.
- DIN rail or chassis mounting.



ROHS Compliant

Ordering Code

S D A 1 Z - 60 U - D

Switch Function

Z	-	Zero Crossover
R	-	Random

Load Current Rating

60	-	60A
80	-	80A

Load Voltage

K	-	40 to 480VAC
---	---	--------------

Control Voltage Input

A	-	90 to 250VAC
D	-	4 to 32VDC

Output (load)

Load type	SPST-NO (1 N/O) Resistive	
Load current	60A, 80A	
Load switching voltage	AC V_{rms}	60 ~ 660V
Maximum peak voltage	AC V_{pk}	900V
Minimum load current	0.1A	
Inrush Current (max.)	10ms	60A: 720A / 80A: 1000A
I^2t	A^2s	60A: 2600 / 80A: 5000
Switch type	Zero Cross (Consult factory for Random)	

Input (control)

Control voltage	V	DC: 4 ~ 32DC / AC: 90 ~ 250AC
Control current	mA	< 20mA
Turn-on voltage (min)	V_{min}	DC: 3.5VDC / AC: 80VAC
Turn-on voltage (max)	V_{max}	DC: 35VDC / AC: 280VAC
Turn-off voltage	V	DC: 2VDC / AC: 40VAC

General Data

Dimensions	L x W x H	100 x 110 x 127mm
Weight		approx. 940g

Schematics

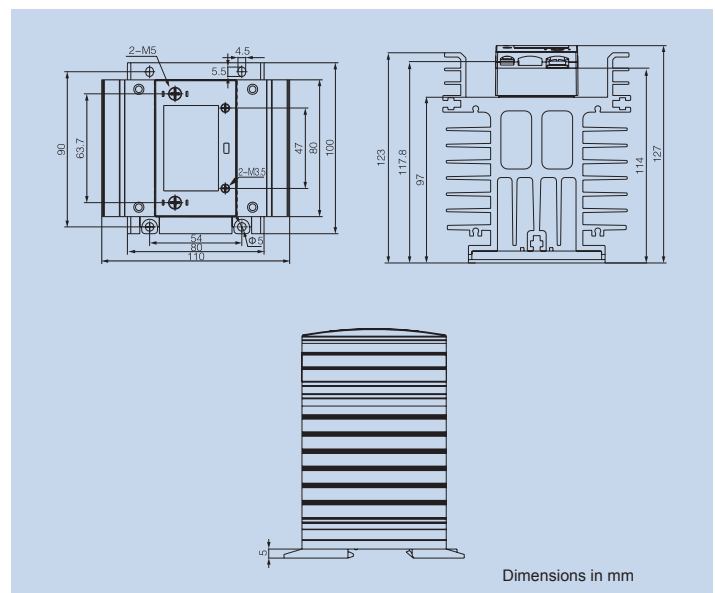
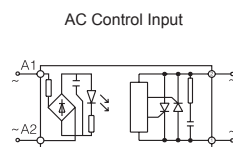
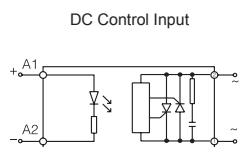
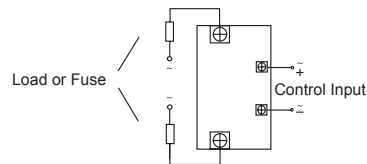



- High load voltage - up to 480VAC.
- 4 ~ 32VDC or 90 ~ 250VAC control voltage.
- Three Phase, Zero cross-over switching.
- LED control input indicator.
- Integrated heatsink.
- DIN rail or chassis mounting.



ROHS Compliant

Ordering Code

S D A 3 Z - 10 K - D

Switch Function

Z	-	Zero Crossover
R	-	Random

Load Current Rating

10	-	10A
15	-	15A

Load Voltage

K	-	40 to 480VAC
---	---	--------------

Control Voltage Input

A	-	90 to 250VAC
D	-	4 to 32VDC

Output (load)

Load type		3PST-NO (3 N/O) Resistive
Load current		10A, 15A
Load switching voltage	AC V_{rms}	40 ~ 480V
Maximum peak voltage	AC V_{pk}	900V
Minimum load current		0.1A
Inrush Current (max.)	10ms	10A: 120A / 15A: 160A
I^2t	A^2s	10A: 72 / 15A: 128
Switch type		Zero Cross (Consult factory for Random)

Input (control)

Control voltage	V	DC: 4 ~ 32DC / AC: 90 ~ 250AC
Control current	mA	< 25mA
Turn-on voltage (min)	V_{min}	DC: 3.5VDC / AC: 80VAC
Turn-on voltage (max)	V_{max}	DC: 35VDC / AC: 280VAC
Turn-off voltage	V	DC: 2VDC / AC: 40VAC

General Data

Dimensions	L x W x H	100 x 110 x 80mm
Weight		approx. 672g

Schematics

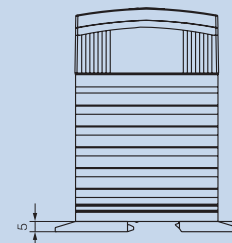
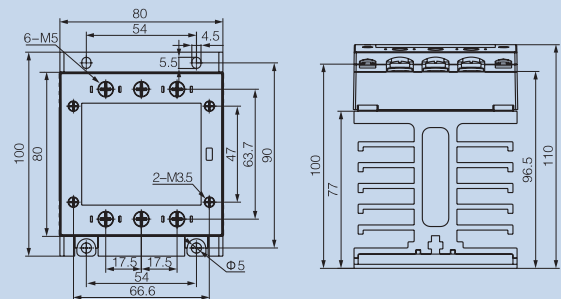
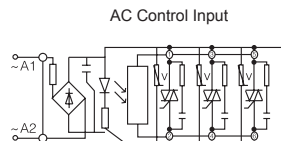
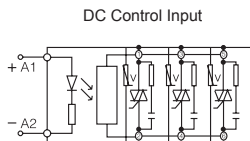
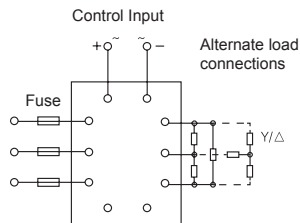

Dimensions in mm

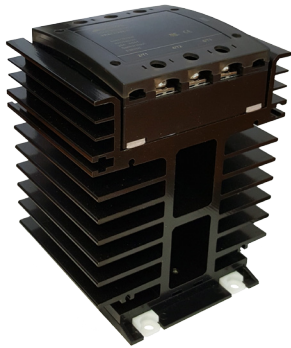

- High load voltage - up to 480VAC.
- 4 ~ 32VDC or 90 ~ 250VAC control voltage.
- Three Phase, Zero cross-over switching.
- LED control input indicator.
- Integrated heatsink.
- DIN rail or chassis mounting.



ROHS Compliant

Output (load)

Load type	3PST-NO (3 N/O) Resistive	
Load current	20A, 25A, 30A	
Load switching voltage	AC V_{rms}	40 ~ 480V
Maximum peak voltage	AC V_{pk}	900V
Minimum load current	0.1A	
Inrush Current (max.)	10ms	20A: 240A / 25A: 300A / 30A: 380A
I^2t	A ² s	20A: 288 / 25A: 450 / 30A: A ² s
Switch type	Zero Cross (Consult factory for Random)	

Input (control)

Control voltage	V	DC: 4 ~ 32DC / AC: 90 ~ 250AC
Control current	mA	< 20mA
Turn-on voltage (min)	V_{min}	DC: 3.5VDC / AC: 80VAC
Turn-on voltage (max)	V_{max}	DC: 35VDC / AC: 280VAC
Turn-off voltage	V	DC: 2VDC / AC: 40VAC

General Data

Dimensions	L x W x H	100 x 110 x 130mm
Weight		approx. 982g

Ordering Code

S D A 3 Z - 25 K - A

Switch Function

Z	-	Zero Crossover
R	-	Random

Load Current Rating

20	-	20A
25	-	25A
30	-	30A

Load Voltage

K	-	40 to 480VAC
---	---	--------------

Control Voltage Input

A	-	90 to 250VAC
D	-	4 to 32VDC

Schematics

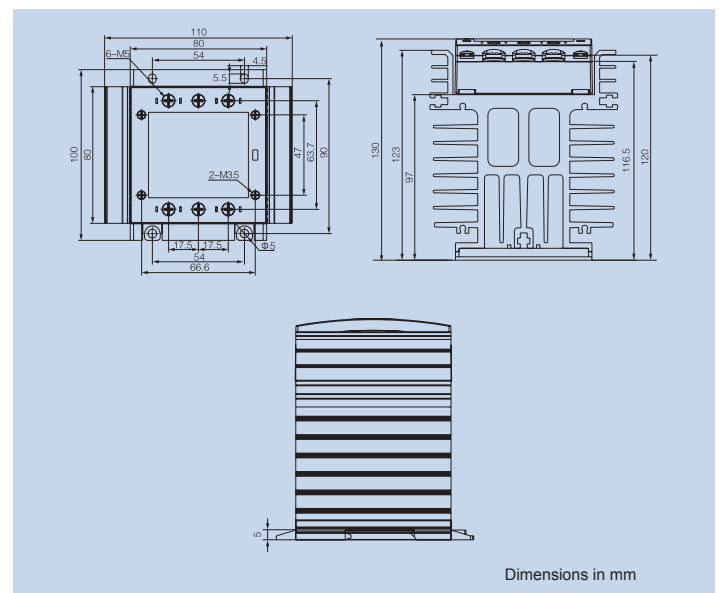
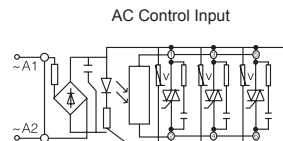
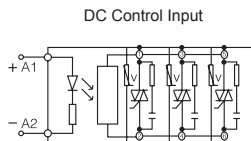
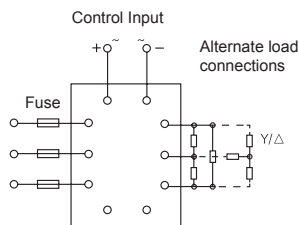



- High load voltage - up to 480VAC.
- 4 ~ 32VDC or 90 ~ 250VAC control voltage.
- Three Phase, Zero cross-over switching.
- LED control input indicator.
- Integrated heatsink, complete with fan.
- DIN rail or chassis mounting.



ROHS Compliant

Ordering Code

S D A 3 Z - 40 K - D

Switch Function

Z	-	Zero Crossover
R	-	Random

Load Current Rating

40	-	40A
----	---	-----

Load Voltage

K	-	40 to 480VAC
---	---	--------------

Control Voltage Input

A	-	90 to 250VAC
D	-	4 to 32VDC

Output (load)

Load type		3PST-NO (3 N/O) Resistive
Load current		40A
Load switching voltage	AC V_{rms}	40 ~ 480V
Maximum peak voltage	AC V_{pk}	900V
Minimum load current		0.1A
Inrush Current (max.)	10ms	450A
I^2t	A^2s	880
Switch type		Zero Cross (Consult factory for Random)

Input (control)

Control voltage	V	DC: 4 ~ 32DC / AC: 90 ~ 250AC
Control current	mA	< 20mA
Turn-on voltage (min)	V_{min}	DC: 3.5VDC / AC: 80VAC
Turn-on voltage (max)	V_{max}	DC: 35VDC / AC: 280VAC
Turn-off voltage	V	DC: 2VDC / AC: 40VAC

General Data

Dimensions	L x W x H	125 x 110 x 130mm
Weight		approx. 1300g

Schematics

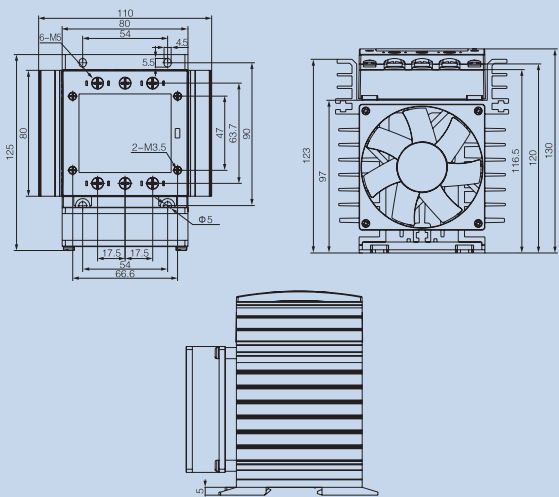
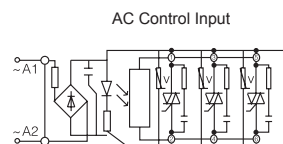
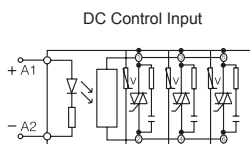
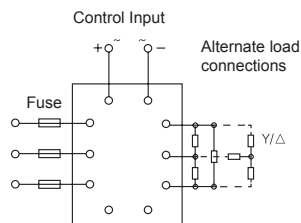

Dimensions in mm

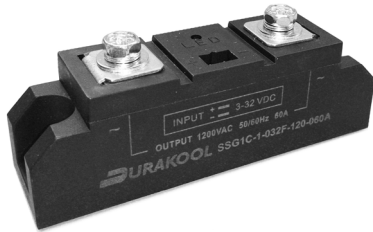

- High current - up to 350A.
- High load voltage - up to 1200VAC.
- 3 to 32VDC control voltage.
- Zero cross-over switching.
- Compact case sizes.
- Heat sinks available



Output (load)

Load type	Resistive	SPST-NO (1 N/O)
Load current		60A ~ 150A, 200A ~ 350A
Load switching voltage	AC V _{rms}	60 ~ 1200V
Maximum peak voltage	AC V _{pk}	1600V
I ² t	A ² s	60A: 3200 / 80A: 5000 / 100A: 7200 / 120A: 11250 150A: 20000 / 200A: 31250 / 250A: 45000 300A: 61250 / 350A: 80000

Input (control)

Control voltage	V DC	3 ~ 14 or 3 ~ 32
Control current	mA	5 ~ 25mA
Turn-on voltage (min)	V DC _{min}	3
Turn-on voltage (max)	V DC _{max}	35
Turn-off voltage	V DC	1

General Data

Dimensions	L x W x H	
	small case	94 x 25 x 36.2mm
	large case	94 x 34 x 43mm
Weight	small case	approx. 135g
	large case	approx. 235g

Ordering Code

S S G 1 C - 0 3 2 F - 1 2 0 - 0 6 0 A

Input control voltage

014	-	3 to 14VDC
032	-	3 to 32V DC

Case sealing

F	-	fully sealed
---	---	--------------

Output (load) voltage

120	-	60 ~ 1200V AC
-----	---	---------------

Load current

060	-	60A	small case size
080	-	80A	
100	-	100A	
120	-	120A	
150	-	150A	
200	-	200A	large case size
300	-	300A	
350	-	350A	

Small Case

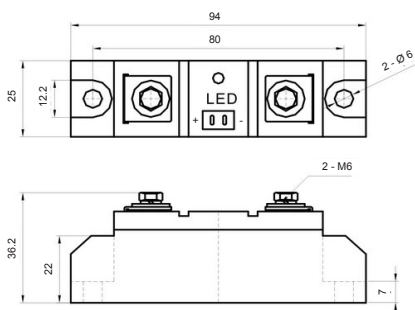

Large Case

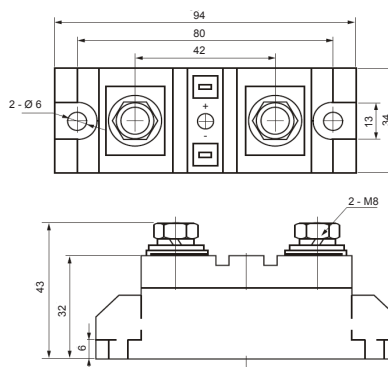

Schematic

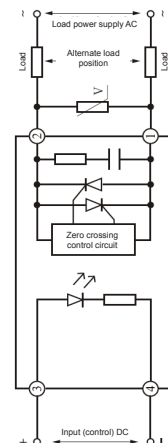

Recommended Durakool heat sinks

SSR Series	SRA1*-10*-*	SRA1*-25*-*	SRA1*-60*-*	SRA1*-80*-*
	SRA1*-15*-*	SRA1*-30*-*		
	SRA1*-20*-*	SRA1*-40*-*		
Current rating	<20A	<40A	<60A	<80A
Heat Sink	DHS01	DHS02	DHS03	DHS04
Heat Sink Rating °C/W	2.19	1.49	1.35	1.07

DHS01

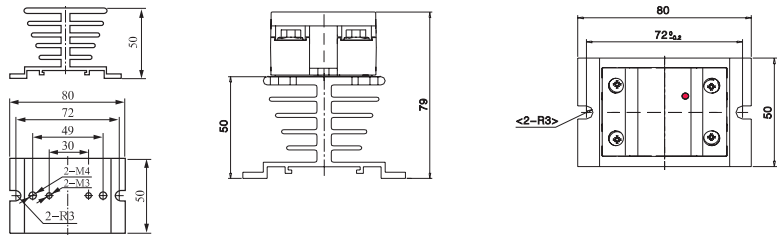
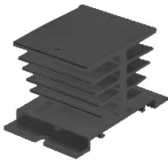

DHS02

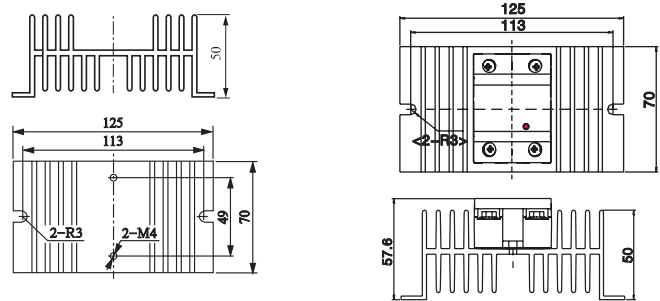
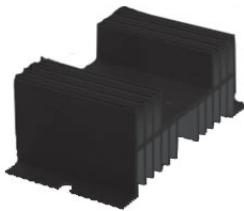

DHS03

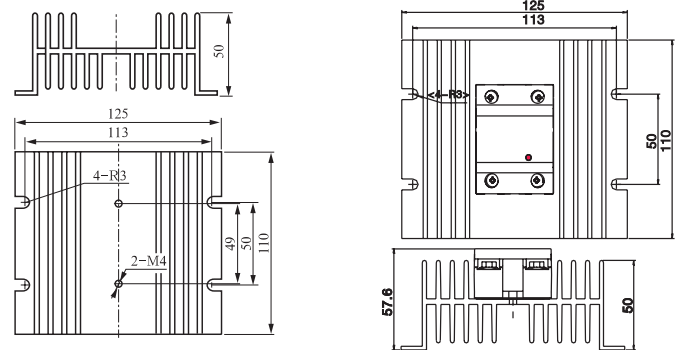

DHS04

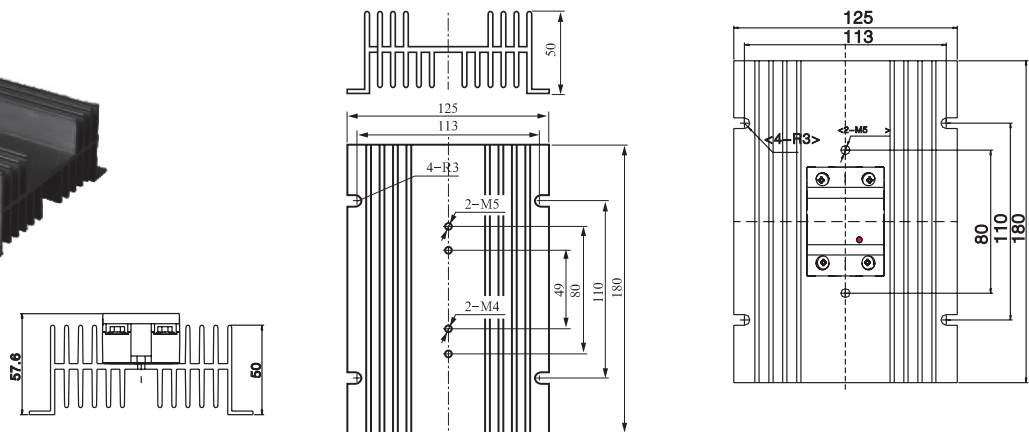
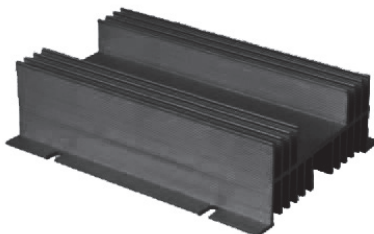

Recommended Durakool heat sinks

SSR Series	SRA3*-10*.*	SRA3*-25*.*	SRA3*-40*.*	SRA3*-60*.*
	SRA3*-20*.*	SRA3*-30*.*		SRA3*-80*.*
Current rating	≤ 20A	≤ 30A	≤ 40A	≤ 80A
Heat Sink	DHS05	DHS06	DHS07	DHS08 (or DHS09)
Heat Sink Rating °C/W	0.93	0.65	0.48	0.44 (0.39)

DHS05

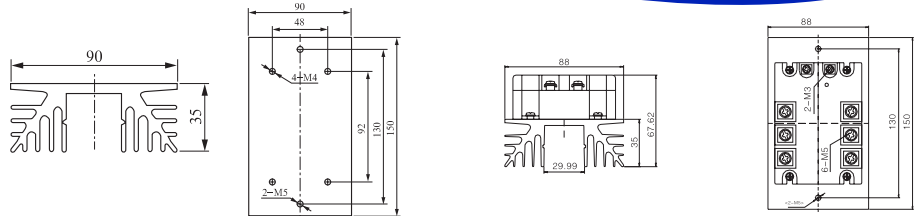
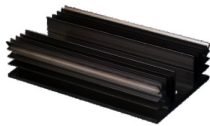

DHS06

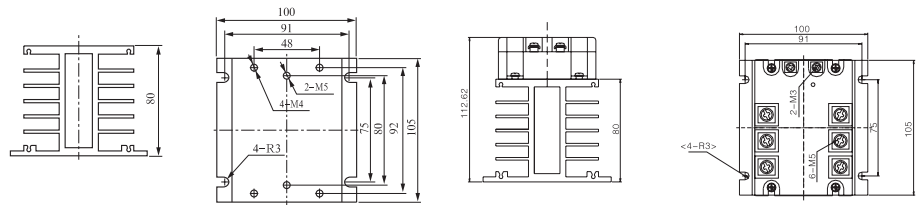

DHS07

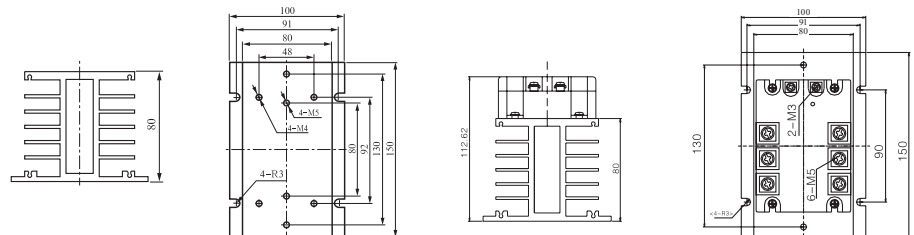

DHS08

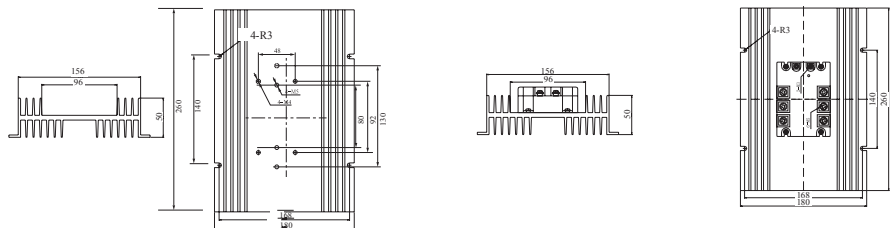
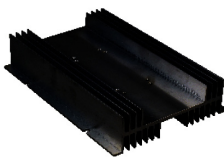

DHS09

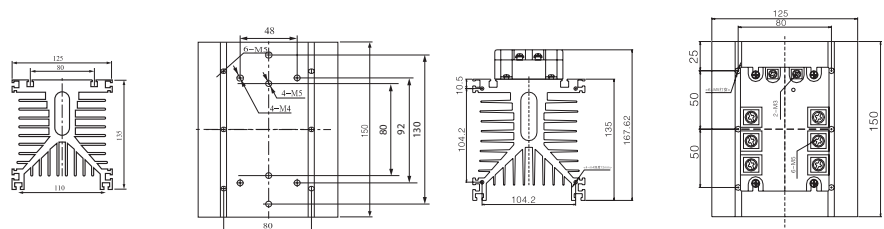
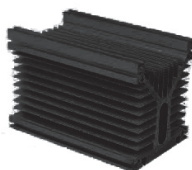

General data:	
Operating time	approx. ½ cycle of load frequency + ≤1ms
Release time	approx. ½ cycle of load frequency + ≤1ms
On voltage drop	1.6VAC
Leakage current (Off)	≤10mA
Insulation resistance	≤500MΩ at 500VDC, 50%RH
Dielectric strength	≥2500VAC
Ambient Temp	-30° to +80°C with derating (no icing)
Relative Humidity	45 ~ 85RH

SDA1 and SDA 3 Solid-State Contactors
Derating Curves

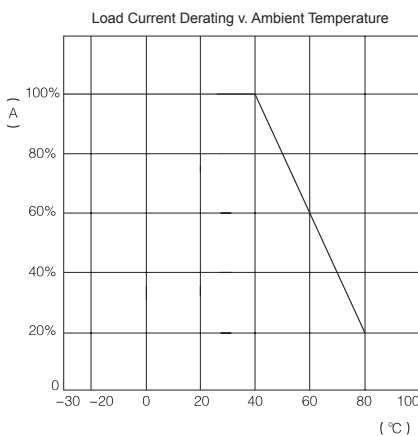

Heat sinks and mounting considerations

The SDA & SDB series of solid-state relays & contactors have integral heat sinks. However, due consideration must be given to cooling air flow over the heat sink to ensure reliable operation and avoid premature failure. If used in an enclosed cabinet, providing vents or forced air ventilation may be necessary. They should be mounted with at least 25mm (1") between separate SDA & SDB units. It is not recommended to mount SSR's touching against each other and care should be taken when mounting multiple units on the same DIN rail to avoid overheating of the middle SSR's.

In order to maintain air flow, a space should be left above and below the heatsink to ensure free air movement. The recommended mounting is with the fins vertically aligned for optimum air flow.

The larger SDA3 Contactors are provided with a cooling fan already attached. It is important that air flow to this fan is clean and unimpeded. Dust build up on the fan or the heat sink will degrade performance of the solid-state contactor.

The SRA1 & SRA3 series of panel mount SSR's are designed to be mounted on individual heat sinks, wherever possible. Referring to the derating curves (below) it can be seen that operating these SSR's without a heat sink seriously reduces their current carrying capacity. To ensure a good thermal contact between the SSR and the heat sink, a thermal heatsink compound should be applied to the SSR. But it is important to use the compound sparingly as too much compound can be almost as bad as no compound. Alternatively, a thermally conductive mounting pad may be used between the SSR and the heat sink.

SRA1 series: Derating Curves

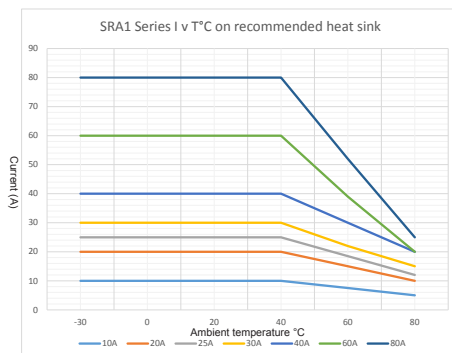
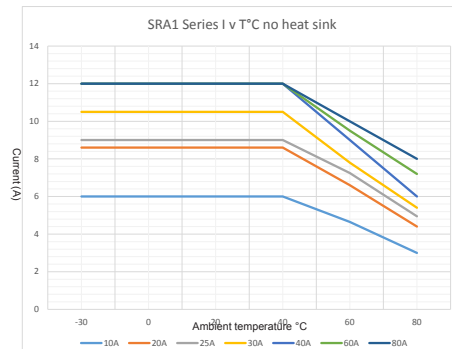

SRA3 series: Derating Curves

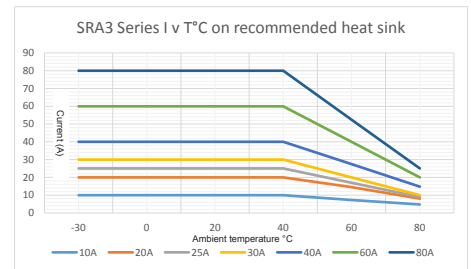
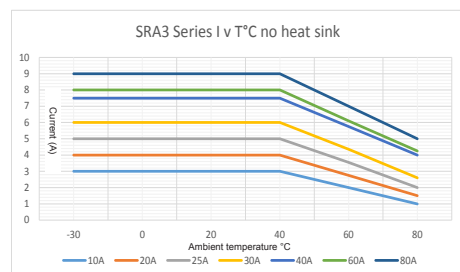

A good "rule of thumb" is to choose a SSR which is rated such that the load power is only 80% of the SSR's rating. This will provide a safety margin in the event of variations in the ambient conditions, or in the load itself, as it ages.

When choosing a suitable heat sink, refer to the data on Pages 16 & 17 which shows the recommended heat sinks for the SRA1 & SRA3 series. The lower the °C/W rating the more heat it dissipates.

If the SSR is mounted on a flat panel, it is important that the relay is mounted on an unpainted surface and a good quality thermal compound is used. Maximum currents will be limited as shown in the graphs. Above these currents, a special heat sink will be required.

If it is anticipated that heat sink temperatures could rise to unacceptable levels, it is suggested that simple thermal switch should be mounted on the heat sink to enable the SSR to be turned off until the heat sink has cooled down. Or a different heat sink and SSR combination considered.

Protection of SSR's - Fuse Selection

The solid-state semiconductor elements used in all SSR's and Solid-state contactors have very short thermal time constants. As a result, extreme current overloads such as a short circuit, or problems with load or line surges, even if applied for very short time periods may cause the SSR to fail permanently. Standard fuses and circuit breakers cannot react quick enough to prevent the SSR being damaged. It is important that correctly sized "Semiconductor" or "Ultra Fast Acting" fuses are used.

Reference to the data sheets for the SSR's and Solid-state Contactors will show an I²t value. This is the value for the maximum current vs. time that the switching semiconductor elements can tolerate. Semiconductor fuses are specified with a corresponding I²t value. **The fuse I²t value must be selected such that it is less than the I²t value for the SSR.**

General Safety Considerations

It must be noted that SSR's are not fully open circuit (off) when not operated. There is always a small leakage current which could possibly pose a safety concern. SSR's can also fail in such a manner that they are conducting even when supposed to be off. It is important that some alternative mechanical disconnect is available to turn the power off in the event of an emergency. Likewise, as mentioned previously, it is a good idea to have some form of heat monitoring for the heat sink such that the power is disconnected in the event of an over heat situation, as might occur if the SSR fails conducting. e.g a suitably sized electro-mechanical contactor in series with the SSR and operated by a bimetallic switch.

Always completely isolate an SSR or Solid-State Contactor and allow it to cool down before touching it. Remember that SSR's and heat sinks could easily be over 100°C when operating correctly. This will cause burns if touched. Be aware that touching an electrically live component is potentially fatal!

Occasionally, problems can occur when controlling loads where the voltage and current are out of phase and a sudden voltage rise occurs during turn-off. In these circumstances, the SSR may fail to turn-off. Likewise, when controlling loads with voltage and current out of phase with a zero crossover type, it is possible that the triac may not turn on regardless of the input state.

It is very important to have a mechanical form of disconnect in order to remove the load and control supply to the SSR in the event of an unexpected event or for routine maintenance.

Load Considerations

The most common application for SSR's is controlling resistance heating elements for which they are well suited. Zero Cross-over Switching will greatly reduce electrical noise when switching.

Resistive Load - Single Phase

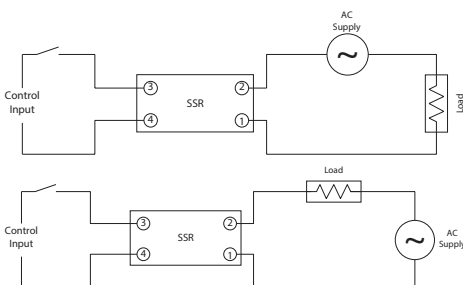

Resistive Load - 3 Phase

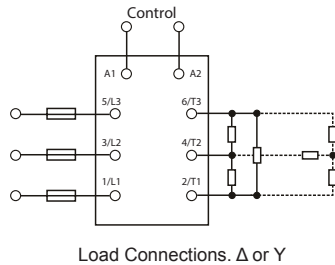

Lamp Loads

Tungsten or halogen lamps have a high inrush current at turn on, which can be 7 or 8 times the steady current, sometimes even more for zero crossover SSR's rising to 9 to 12 times (in the worst case) for random turn on SSR's. When choosing an SSR to switch these loads, due consideration should be taken to ensure that the inrush current does not exceed 50% of the SSR surge on current.

Motor Loads

Motors present a substantial inrush current as the motor tries to overcome the mechanical inertia imposed mostly by the load. The length of time of this start current is, in part, dependent upon the characteristics of the mechanical load (LRA or Locked Rotor Current). Once the motor is up to speed, the current drops back until it settles at a constant level. This is the Full Load Current or FLA).

Induction Motors can present a significant shift between voltage and current for each phase, where the phase current lags behind the phase voltage. In these applications, zero cross-over SSR's are not suitable. The zero cross-over function means that each phase will be turned on sequentially, instead of all at the same time. In some cases, it is even possible that the relay will fail to turn on. The solution is a random turn-on SSR which will switch power to all of its outputs with 100us of the input signal being applied. All three phases are therefore supplied to the motor simultaneously and phase shifts between voltage and current are no longer a problem.

When choosing a SSR to switch a motor load, calculations must take into account the initial inrush current which can be as much as 5 or 7 times the normal operating current. Thought must also be given to the fact that the motor may stall which could result in a current equal or greater than the LRA value. Over current protection should be considered as well as choosing a suitably rated SSR.

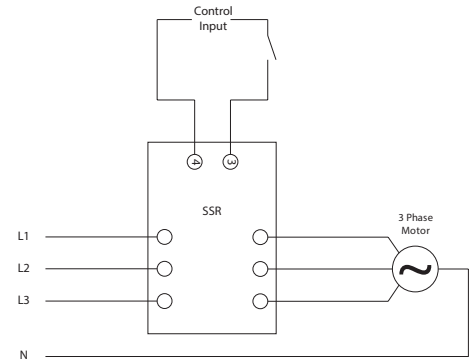

Motor loads - Three Phase

The most common wiring arrangement for 3 phase induction motors is the "Y".

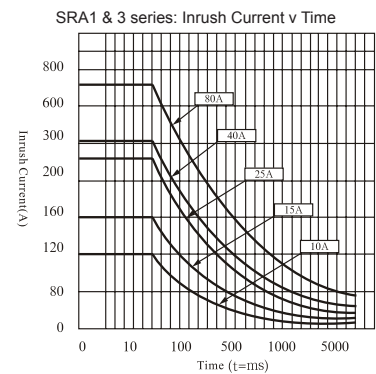

The logo for DURAKOOL, featuring the word "DURAKOOL" in a bold, white, sans-serif font. The letter "D" is stylized with a horizontal bar extending to the left. The background of the logo area is a vibrant blue with abstract, flowing, and overlapping light patterns that create a sense of motion and depth.

DURAKOOL