

LED Indicator Light

Features

- Projecting LED or with reflector
- Low power consumption
- Solder pin terminals
- Used within circuit boards and electronic designs



Specification

Insulation Resistance	100 MOhm min. @ 500 VDC
Dielectric Strength	200 VAC for 1 min.
Operating Temperature	-25 ... 70 °C
Circuit Voltage	2 VDC
Hand Soldering	350 +/- 5°C for 3 sec. max.
LED Colour	Yellow
Forward Current	20 mA
Luminous Intensity	20 mcd
Peak Wavelength	590 nm

Pull Force Between Terminal & Base

Normal Type	2 kgf for 1 min.
Sealed Type	5 kgf for 1 min.

Pull Force Between Base & Body

Normal Type	2 kgf for 1 min.
Sealed Type	5 kgf for 1 min.

Material Specification

Body	Polycarbonate UL94V-0 or Acrylic
Base	Glass Fiber Polyamide, UL94-V0
Illuminant	LED
Terminal	Copper Alloy, Tin Plated over Nickel
Washer	Polyamide, UL94-V0 or Iron Hoop
Nut	M10x0.75P or M15x1P Iron

Drawing

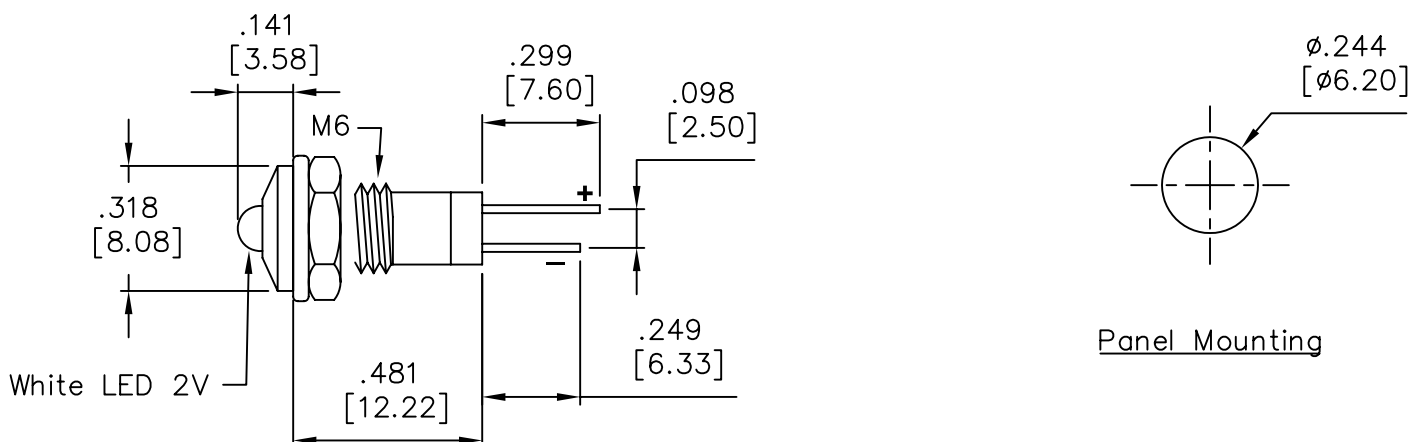

Art Nr.

RND 210-00679