

Triple-Strand Sprockets DRS with Hub, ISO 12 B-3

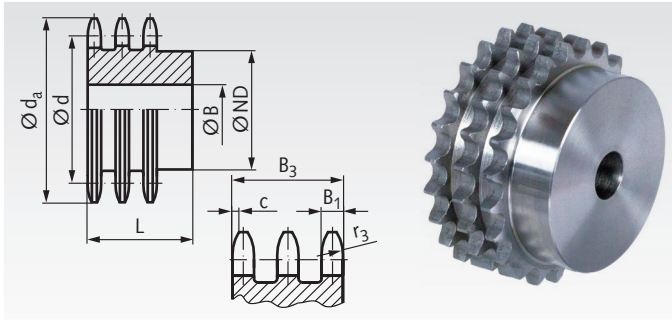

Material: Steel C45, not hardened.
Pre-bored.
Sprockets marked with * are made from grey cast iron GG25.

Ordering Details: e.g.: Product No. 137 108 00, DRS, ISO 12 B-3, 8 Teeth

ISO 12 B-3, Pitch 3/4 x 7/16"

$B_1 = 10.8 \text{ mm}$, $B_3 = 49.8 \text{ mm}$, $c = 2.0 \text{ mm}$, $r_3 = 19 \text{ mm}$

Product No.	Number of teeth	d_a mm	d mm	ND mm	B mm	L mm	Weight kg
137 108 00	8	58,0	49,78	31	16	65	0,45
137 110 00	10	69,8	61,64	42	16	65	0,86
137 111 00	11	75,8	67,61	47	20	70	1,09
137 112 00	12	81,8	73,60	53	20	70	1,39
137 113 00	13	87,8	79,59	59	20	70	1,72
137 114 00	14	93,8	85,61	65	20	70	2,08
137 115 00	15	99,8	91,63	71	20	70	2,47
137 116 00	16	105,8	97,65	77	20	70	2,89
137 117 00	17	111,9	103,67	83	20	70	3,34
137 118 00	18	117,9	109,71	89	20	70	3,83
137 119 00	19	123,9	115,75	95	20	70	4,35
137 120 00	20	130,0	121,78	100	20	70	4,87
137 121 00	21	136,0	127,82	100	20	70	5,20
137 122 00	22	142,0	133,86	100	20	70	5,65
137 123 00	23	148,1	139,90	110	20	70	6,38
137 124 00	24	154,1	145,94	110	20	70	6,87
137 125 00	25	160,2	152,00	120	20	70	7,77
137 127 00	27	172,9	164,09	120	20	70	8,77
137 130 00	30	190,4	182,25	120	20	70	10,59
137 138 00	38	238,9	230,69	130	25	70	16,73
137 145 00*	45	283,2	273,10	140	30	70	13,30
137 157 00*	57	355,9	345,81	140	40	70	15,25
137 176 00*	76	471,1	460,99	160	40	75	27,20
137 183 00*	95	586,2	576,17	170	40	82	36,40

Triple-Strand Plate wheels DRL, ISO 12 B-3

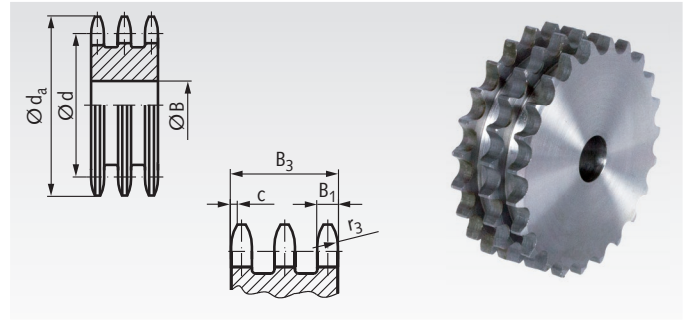

Material: Low-carbon steel, not hardable.
Pre-bored.

Ordering Details: e.g.: Product No. 137 211 00, DRL, ISO 12 B-3, 11 Teeth

ISO 12 B-3, Pitch 3/4 x 7/16"

$B_1 = 10.8 \text{ mm}$, $B_3 = 49.8 \text{ mm}$, $c = 2.0 \text{ mm}$, $r_3 = 19 \text{ mm}$

Product No.	Number of teeth	d_a mm	d mm	B mm	Weight kg
137 211 00	11	75,8	67,61	16	0,91
137 212 00	12	81,8	73,50	16	1,13
137 213 00	13	87,8	79,59	16	1,38
137 214 00	14	93,8	85,61	16	1,64
137 215 00	15	99,8	91,63	16	1,93
137 216 00	16	105,8	97,65	20	2,20
137 217 00	17	111,9	103,67	20	2,54
137 218 00	18	117,9	109,71	20	2,89
137 219 00	19	123,9	115,75	20	3,27
137 220 00	20	130,0	121,78	20	3,67
137 221 00	21	136,0	127,82	20	4,10
137 222 00	22	142,0	133,86	20	4,55
137 225 00	25	160,2	152,00	20	6,02
137 230 00	30	190,4	182,25	20	8,97
137 235 00	35	220,7	212,52	25	12,35
137 238 00	38	238,9	230,69	25	14,70
137 240 00	40	251,0	242,81	25	16,40
137 245 00	45	283,2	273,10	25	21,00
137 248 00	48	301,4	291,27	25	24,04
137 250 00	50	312,3	303,39	25	26,17
137 257 00	57	355,9	345,81	30	34,28
137 276 00	76	471,1	460,99	30	62,09
137 283 00	95	586,2	576,17	30	98,04

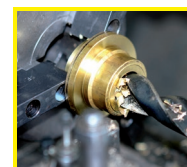

**Reworking within
24h-service possible.
Custom made parts
on request.**