

Curvette LRA-Series

Single Pole Lighted Rocker & Paddle Switches

Since its introduction, the Curvette switch has become the barometer for versatility and performance in the miniature switch market. This lighted version features the very same self cleaning contacts, International approvals, along with a wide variety of circuits, ratings, and actuator options that make the Curvette the switch of choice for sundry markets including HVAC, Office Lighting, Transportation, Commercial Food and Lawn & Garden.



Carling Technologies®

Innovative Designs. Powerful Solutions.

Innovative Designs. Powerful Solutions.

Carling Technologies, Inc.
60 Johnson Avenue • Plainville, CT 06062-1177
Phone: (860) 793-9281 • Fax: (860) 793-9231
Email: sales@carlingtech.com • www.carlingtech.com

Dielectric Strength

UL/CSA:
1000V-live to dead metal parts
VDE:
4000V - live to dead metal parts;
750V - across open contacts

Electrical Life

100,000 cycles

Mechanical Life

100,000 cycles

Operating Temperature

32°F to 185°F (0°C to 85°C)

LRA911 - **R** **S** - **B** / **250N**

1
Base Part Number

2
Actuator Style

3
Actuator Color

4
Bezel Color/Style

5
Lamp Voltage

1 BASE PART NUMBER: SERIES/CIRCUITRY/RATING²/TERMINATION

125 neon lamp (use 125N in Selection 5 Lamp Voltage)
10A 250VAC; 16A 125VAC; 10(4)A 125VACu
Solder Lugs .250 Tabs Wire Leads
LRA210 LRA211 LRA215
OFF-NONE-ON
250 neon lamp (select 250N in selection 5 Lamp Voltage)
15A 250 VAC; 10A 250VAC; 16A 125VAC; 10(4)A 250 T85
Solder Lugs .250 Tabs Wire Leads
LRA910 LRA911 LRA915
Incandescent lamp (select 006V-024V in selection 5 Lamp Voltage)
10A 30V
Solder Lugs .250 Tabs Wire Leads
OFF-NONE-ON **LRA510 LRA511 LRA515**

3 ACTUATOR COLOR

translucent	clear
A Amber	A Amber
C White	C Clear
P Yellow	G¹ Green
S Red	B¹ Blue
W Pale Red	R Red

4 BEZEL COLOR/STYLE

STANDARD	OVAL
B Black (matte)	1 Black (gloss)
W White (matte)	2 White (gloss)

2 ACTUATOR STYLE

P Paddle
R Rocker translucent
C Rocker Clear

5 LAMP VOLTAGE

006V 6 volts incandescent
012V 12 volts incandescent
018V 18 volts incandescent
024V 24 volts incandescent
125N¹ 125 volts neon
250N¹ 250 volts neon

Notes:
LED illumination, PC terminals, independent lamps, and additional color options are available. Consult factory.

- 1 Neon lamps not available with blue or green actuators.
- 2 Consult factory for additional ratings.

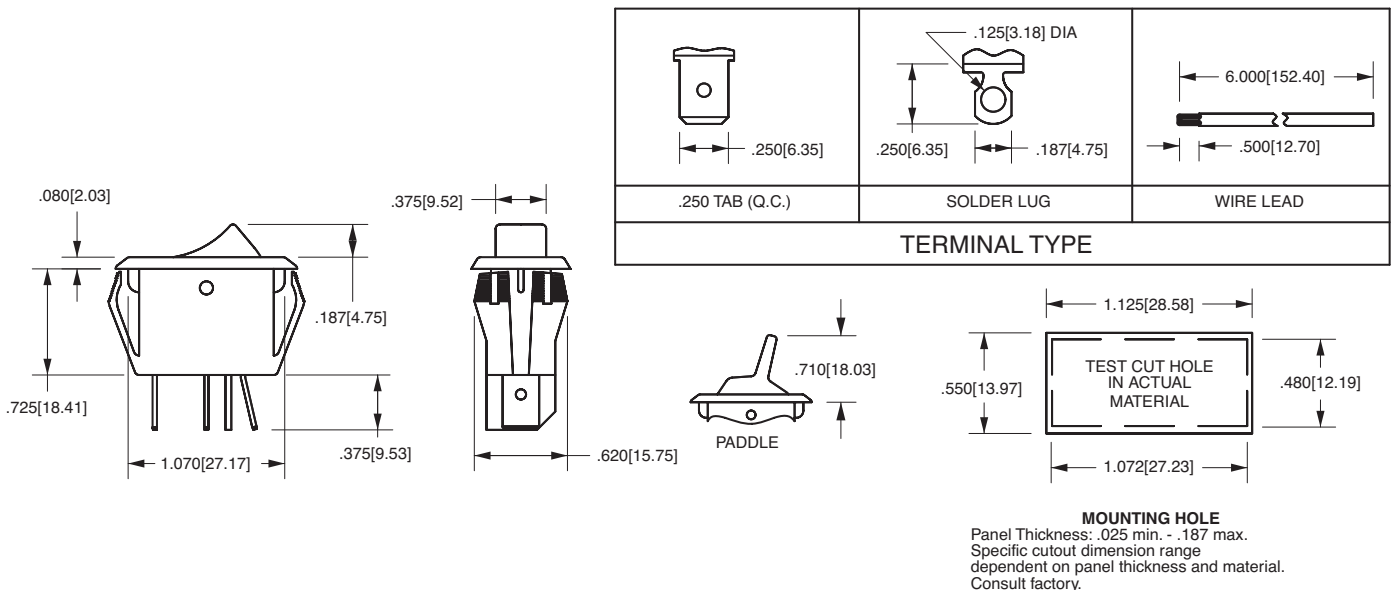

*Manufacturer reserves the right to change product specification without prior notice.