

1 Products affected

Product hierarchy no. *			Part no.	SBU	Type / Description	Customer part no.
SBU	PG	PGU	Type			
02	007	038	0000002289	4789.1100	Connectors	4789 Plug Connector for cable 16A
02	007	038	0000002289	4789.1200	Connectors	4789 Plug Connector for cable 16A

*SBU (2-digit) / PG (3-digit) / PGU (3-digit) / Type (10-digit)

2 Type of change

Renewal of the approval marks.
 The opening for the cable guard is new round for better holding in the housing.
 The marking UL/CSA rating 21A has changed according to UL60320 to 20A.

3 Detailed description of change

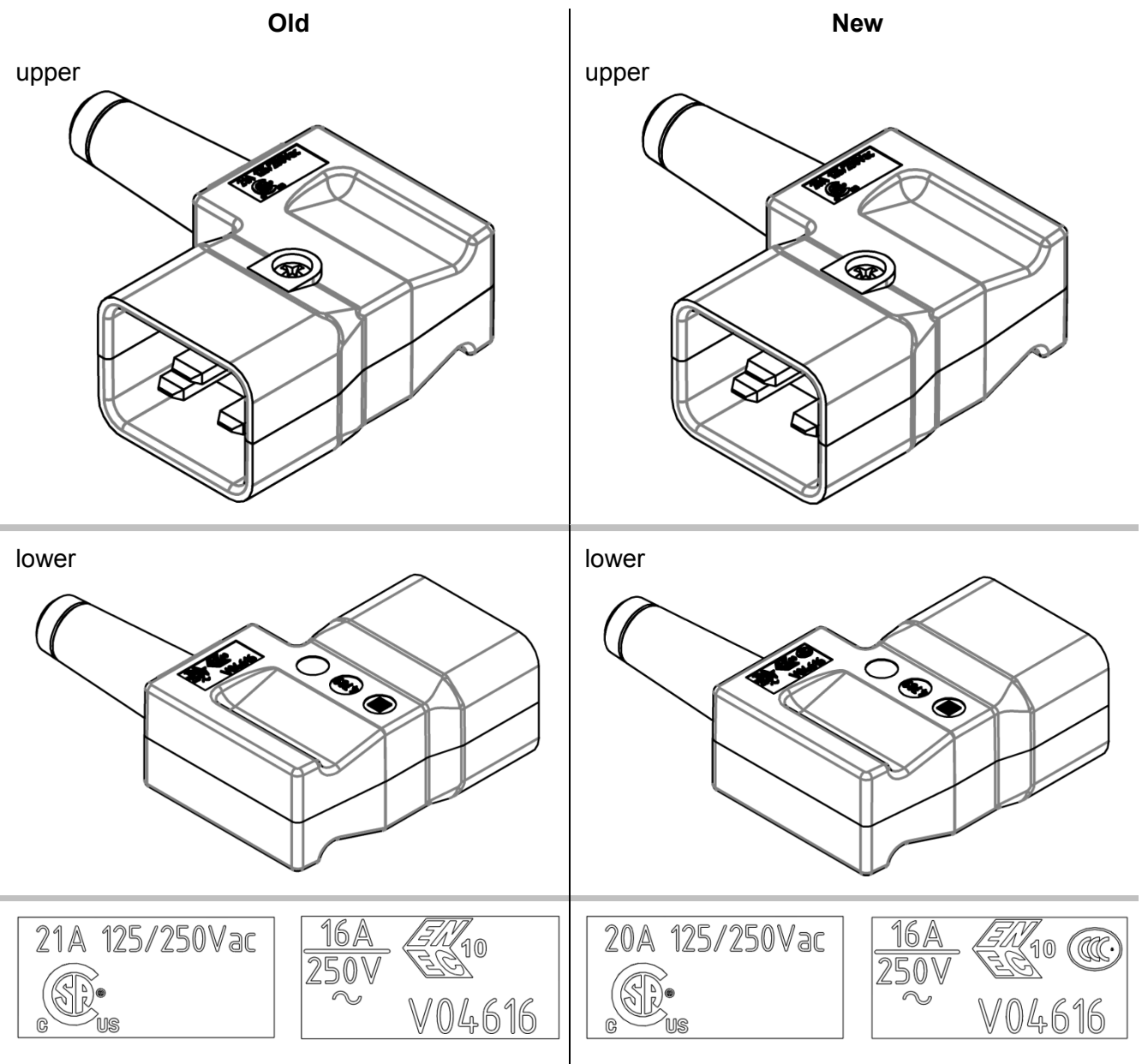

4789					0118.2132	
creation date	created by	release date	released by	notification no.	revision	page
2012-10-02	haechlsa	2013-04-11	haechlsa	24635	b	1 of 2

The opening of the housing has changed

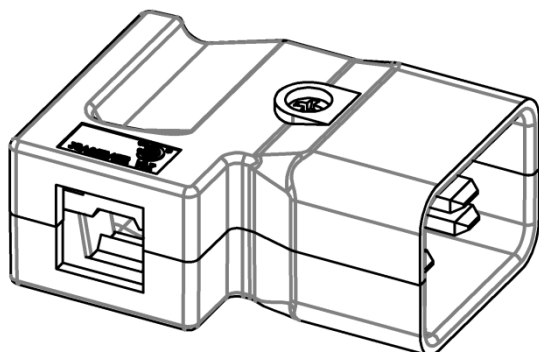

A cable guard with square fastening groove was used

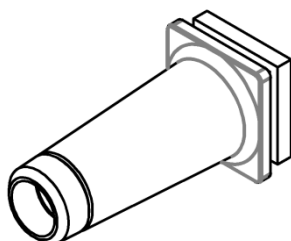

The NEW opening of the housing looks like this

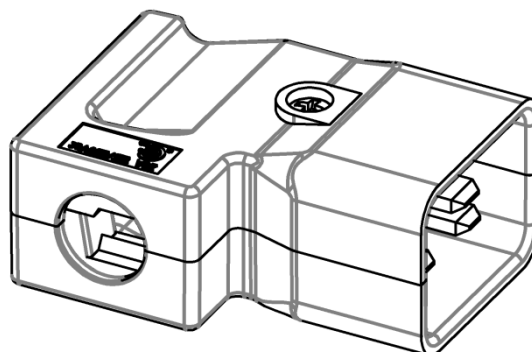

NEW a cable guard with round fastening groove is used

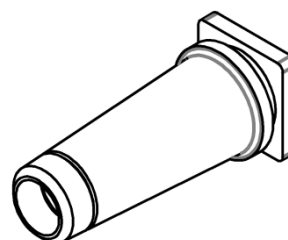

4 Reason of change

Update and renewal of approval marks: CSA 20A 125/250Vac
CCC

To pass the stronger test requirements according to IEC 60320-1 (Sect. 22: Cords and their connection), flange and slot on the cable guard had to be reinforced. As there have been made new tools for the moulding parts the holding of the cable guard got improved with a round opening.

5 Release date

The change will be rolled-out individually by all part numbers affected starting ww 18/2013 and last approx. 2 months.

6 Impact of change and recommended action

Form: Round opening for the cable guard
New approval marks
Fit: n/a
Function: n/a
Production Site: n/a
Product Label: n/a

7 Reference Documents / Attachments

Kind of document	Document number	Remarks
PCN	0118.2109	Cable guard new with square flange

4789					0118.2132	
creation date	created by	release date	released by	notification no.	revision	page
2012-10-02	haechlsa	2013-04-11	haechlsa	24635	b	2 of 2