

# Customer Information Sheet

DRAWING No.: S7091-42R

SHEET 2 OF 2

IF IN DOUBT - ASK

©

NOT TO SCALE

THIRD ANGLE PROJECTION

ALL DIMENSIONS IN mm

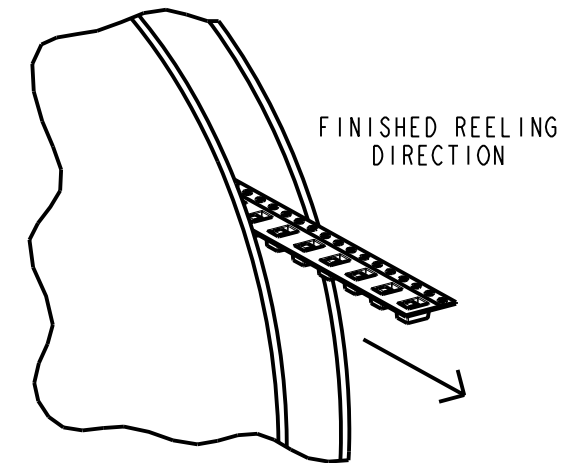
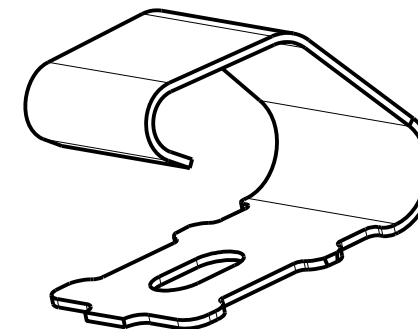
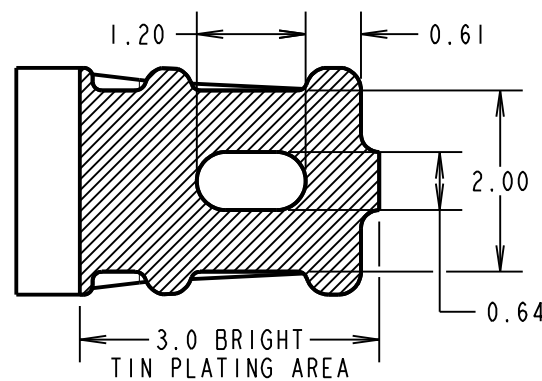
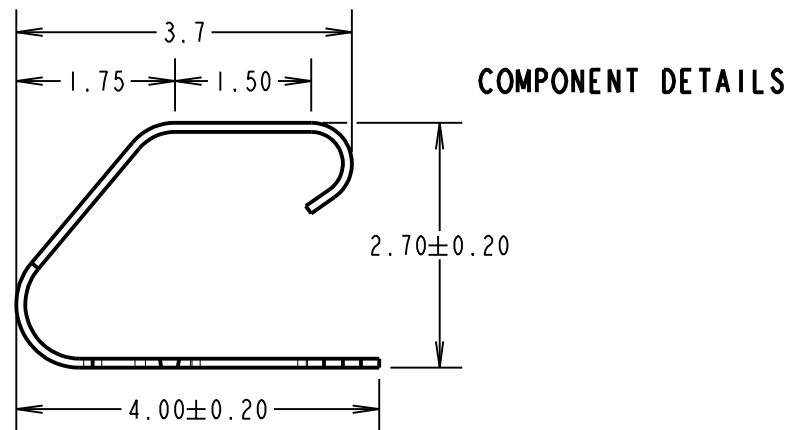
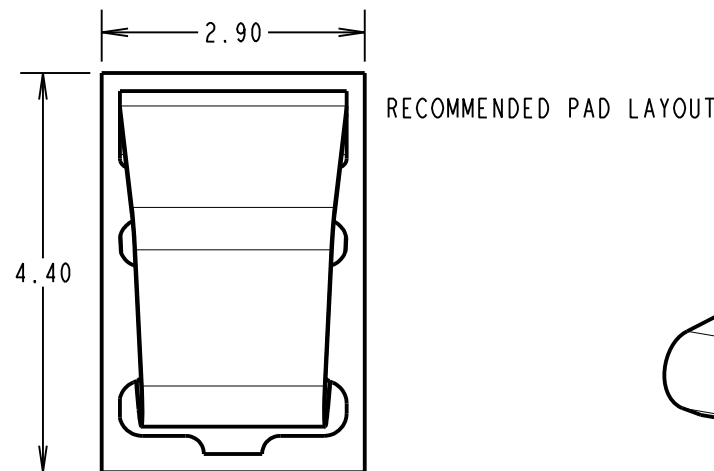
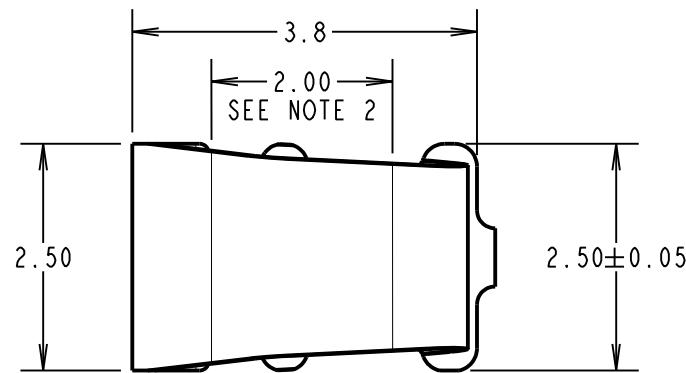
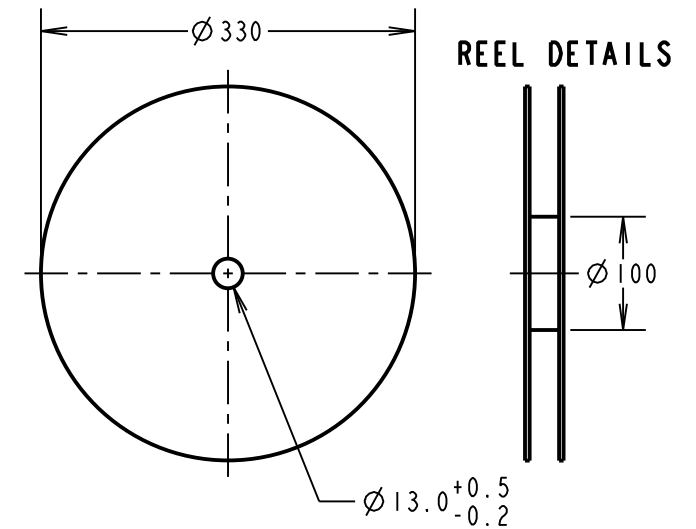
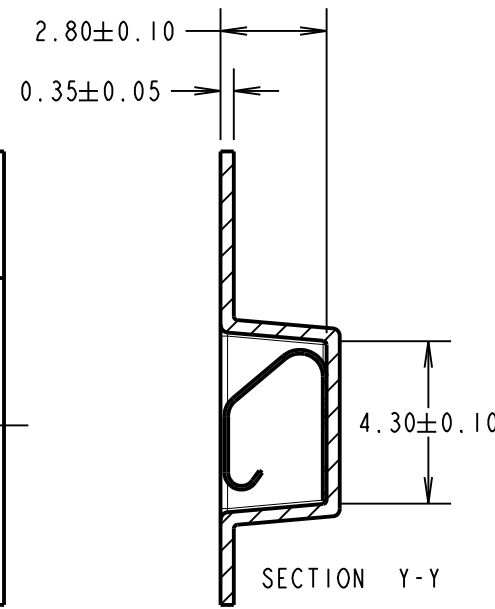
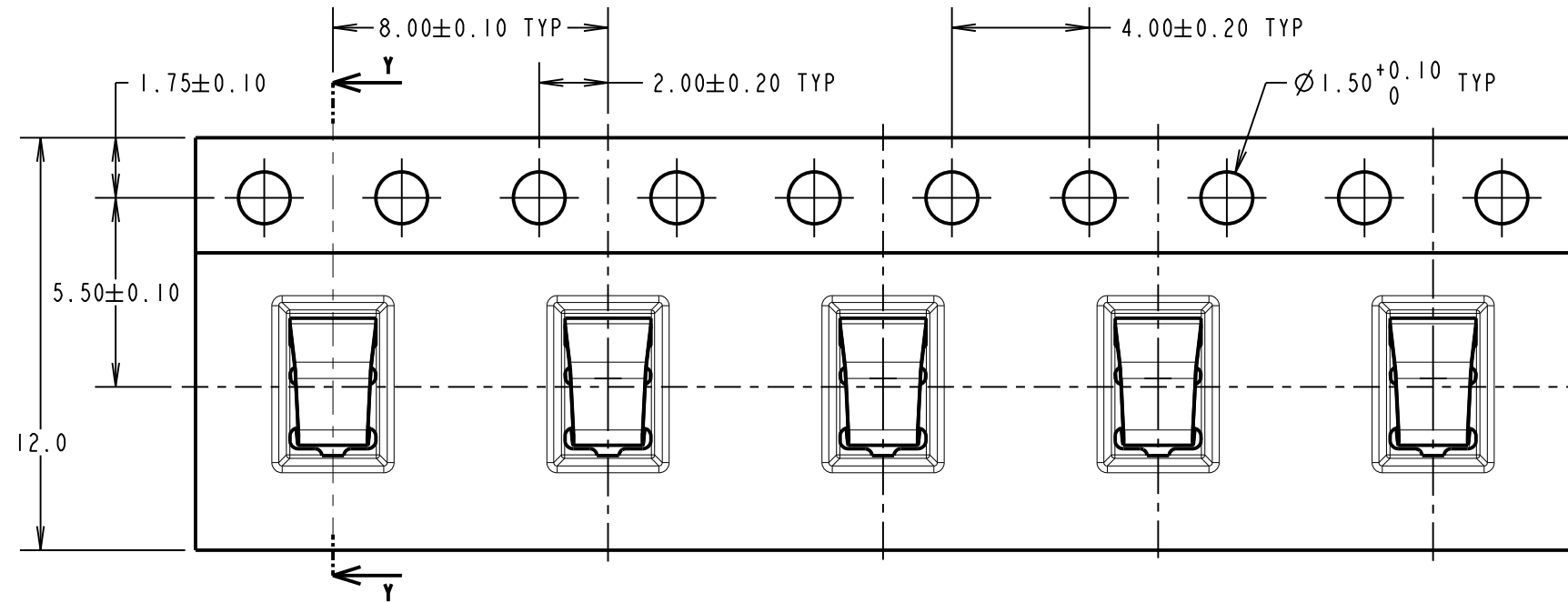

**COMPONENT SPECIFICATION:**  
 MATERIAL = TITANIUM COPPER ALLOY  
 0.10mm THICK  
 FINISH = 0.7µm-1.3µm NICKEL, GOLD FLASH  
 ON CONTACT AND 2.54µm MIN 100%  
 TIN ON FOOT AREA.  
 RECOMMENDED WORKING HEIGHT = 2.30mm / MIN FORCE = 1.2N  
 RECOMMENDED MINIMUM WORKING HEIGHT = 1.90mm  
 ELECTRICAL:  
 CURRENT RATING = 6A  
 MECHANICAL:  
 DURABILITY = 2000 CYCLES  
 ENVIRONMENTAL:  
 OPERATING TEMPERATURE = -55°C TO +125°C

**NOTES:**  
 1. QUANTITY PER REEL = 2500.  
 2. GOLD PLATED AREA.  
 3. ALL TOLERANCES ARE: X.X = ±0.30mm  
 X.XX = ±0.15mm  
 UNLESS OTHERWISE STATED.

MGP	7	05.01.22	31219
NAME	ISS.	DATE	CN/CO
APPROVED: MGP			
CHECKED: MR			
DRAWN: R. ADDE			
CUSTOMER REF.:			
ASSEMBLY DRG:			

 www.harwin.com technical@harwin.com	THIS DRAWING AND ANY INFORMATION OR DESCRIPTIVE MATTER SET OUT HEREON ARE CONFIDENTIAL AND COPYRIGHT PROPERTY OF THE HARWIN GROUP AND MUST NOT BE DISCLOSED, LOANED, COPIED OR USED FOR MANUFACTURING, TENDERING OR FOR ANY OTHER PURPOSE WITHOUT THEIR WRITTEN PERMISSION.	TOLERANCES X = ±1mm X.X = ±0.50mm X.XX = ±0.20mm X.XXX = ±0.01mm ANGLES = ±5° UNLESS STATED	MATERIAL: SEE ABOVE	TITLE: SMT SHIELD FINGER (2.7mm) IN TAPE AND REEL
		FINISH: SEE ABOVE	DRAWING NUMBER: S7091-42R	S/AREA: mm <sup>2</sup>