

Contact Points and Clamp Holders

Optional Accessories for Dial Test Indicator

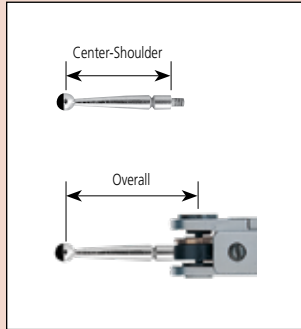

Inch											
Length (mm)		Part No.						Test Indicator Code No.			
Center-Shoulder	Overall	ø0.5	ø0.7	ø1	ø2	ø3	Ruby ø2mm				
11.5	15.0	—	—	136076	136075	136077	21CZA213	513-403-10E 513-453-10E	513-443-10A 513-463-10E	513-473-10E ^{1,3} 513-443-16A	
16.4	19.9	—	—	133196	133195	133197	21CZA204	513-401-10E 513-406-10E 513-452-10E	513-442-10A 513-462-10E	513-472-10E ^{1,3} 513-442-16A 513-482-10A	
30.4	33.9	—	—	136291	136290	136292	21CZA214	513-412-10E 513-446-16A	513-446-10A		
15.2	18.7	—	—	131314	103011	131315	—	513-504 ¹	513-528 ¹		
23.0	26.5	—	—	103008	103007	103009	—	513-518 ¹			
33.9	37.4	—	—	131316	131324	131317	—	513-512 ¹			

Metric											
Length (mm)		Part No.						Test Indicator Code No.			
9.4	12.9	—	—	21CZA044	21CZA036	21CZA045	21CZA212	513-401-10E	513-471-10E		
11.2	14.7	190547	190548	103017	103010	103018	21CZA209	513-405-10E 513-503E 513-527E	513-425-10E 513-455-10E 513-455-10E	513-445-10E	
17.4	20.9	190549	190550	103013	103006	103014	21CZA201	513-404-10E 513-464-10E 513-484-10E	513-444-10E 513-517E ¹	513-454-10E 513-474-10E ^{1,3}	
18.7	22.2	190654	190653	137558	137557	137559	21CZA210	513-424-10E 513-478-10H ³	513-426-10E	513-466-10E	
41.0	44.5	190656	190655	136235	136013	136236	21CZA211	513-415-10E	513-515T ¹		
33.3	36.8	—	—	137746	129949	137747	—	513-414-10E	513-514E ¹		
8.6	12.0	—	—	136756	136104	136758	—	513-501E ¹			
6.5	24.0	—	—	102824	102825	102826	—	513-304GE ²	513-302G ²		

*1 Denotes Pocket Indicators
 *2 Denotes Universal Indicator
 *3 Indicator Ships with Ruby Contact

Holding Bars (with 6mm mounting pin)

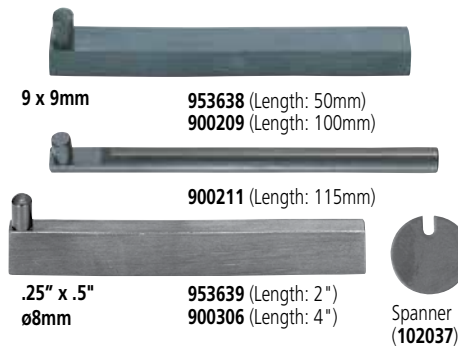

Universal Holder

- Allows the indicator to be set at a desired position.

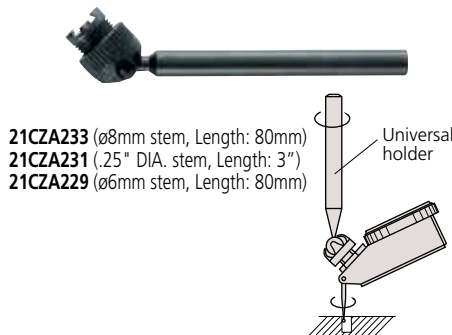

Centering Holder

- Allows large diameter cylinders or holes to be centered.

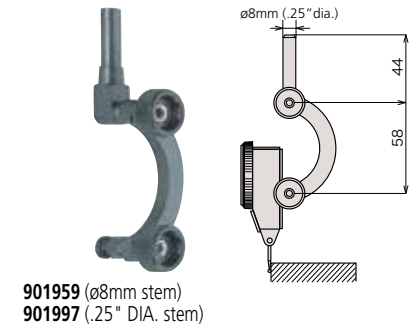

Universal Holder (pocket type)

- Since the Dial Test Indicator can be swiveled to a desired angle, the holder is useful for centering workpieces and installing workpieces on a milling machine.

