

## QSH2818-x-8k Hardware Manual

Hardware Version V1.00 | Document Revision V1.40 • 16.04.2021

**QSH2818-x-8k is a NEMA11 (28mm) 2-phase stepper motor including a small size optical incremental encoder kit. It comes with a resolution of 512 lines (32768 counts). Trinamic's Stepper motors are quality motors for universal use. They feature a long life due to ball bearings and no wearing out parts.**



### Features

- Low Cost
- High Resolution
- Small Dimension
- Easy Mounting

### Applications

- Stepper Motor Servo
- Precision Motion Control
- Position Monitoring
- Automated Equipment
- Robotics

### Simplified Block Diagram

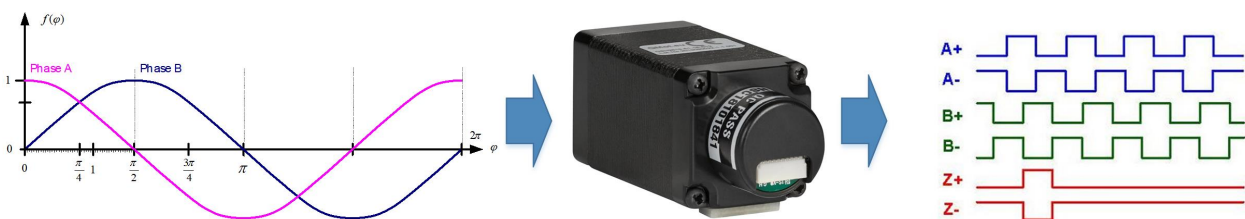

# Contents

|           |   |           |
|-----------|---|-----------|
| <b>1</b>  | <b>Order Codes</b>                                    | <b>3</b>  |
| <b>2</b>  | <b>Motor Specifications and Characteristics</b>       | <b>4</b>  |
| 2.1       | Technical and Mechanical Parameters                   | 4         |
| 2.2       | Torque-Speed Diagrams                                 | 5         |
| 2.2.1     | QSH2818-32-07-006-8k                                  | 5         |
| 2.2.2     | QSH2818-51-07-012-8k                                  | 6         |
| <b>3</b>  | <b>Technical Specifications of the Encoders</b>       | <b>6</b>  |
| 3.1       | Electrical Encoder Parameters                         | 6         |
| 3.2       | Mechanical Encoder Parameters                         | 7         |
| 3.3       | Environmental Encoder Parameters                      | 7         |
| <b>4</b>  | <b>Connectors and Signals</b>                         | <b>7</b>  |
| 4.1       | Motor Connector                                       | 7         |
| 4.2       | Encoder Connector                                     | 8         |
| 4.3       | Wave Form   | 9         |
| <b>5</b>  | <b>Mechanical Drawings</b>                            | <b>10</b> |
| <b>6</b>  | <b>Considerations for Operation</b>                   | <b>11</b> |
| 6.1       | Choosing the best Fitting Motor for an Application    | 11        |
| 6.1.1     | Determining the Maximum Torque Required               | 11        |
| 6.2       | Motor Current Settings                                | 11        |
| 6.2.1     | Choosing the Optimum Current Setting                  | 12        |
| 6.2.2     | Choosing the Standby Current Setting                  | 12        |
| 6.3       | Motor Driver Supply Voltage                           | 13        |
| 6.3.1     | Determining if the Given Driver Voltage is Sufficient | 13        |
| 6.4       | Back EMF (BEMF)                                       | 14        |
| 6.5       | Choosing the Commutation Scheme                       | 14        |
| 6.5.1     | Fullstepping  | 15        |
| <b>7</b>  | <b>Figures Index</b>                                  | <b>16</b> |
| <b>8</b>  | <b>Tables Index</b>                                   | <b>17</b> |
| <b>9</b>  | <b>Supplemental Directives</b>                        | <b>18</b> |
| 9.1       | Producer Information                                  | 18        |
| 9.2       | Copyright   | 18        |
| 9.3       | Trademark Designations and Symbols                    | 18        |
| 9.4       | Target User   | 18        |
| 9.5       | Disclaimer: Life Support Systems                      | 18        |
| 9.6       | Disclaimer: Intended Use                              | 18        |
| 9.7       | Collateral Documents & Tools                          | 19        |
| <b>10</b> | <b>Revision History</b>                               | <b>20</b> |
| 10.1      | Hardware Revision                                     | 20        |
| 10.2      | Document Revision                                     | 20        |



## 1 Order Codes

| Order Code           | Old Order Code            | Description   | Size mm (HxWxL) |
|----------------------|---------------------------|---|-----------------|
| QSH2818-32-07-006-8k | QSH2818-32-07-006-8192-AT | Motor + Encoder Module, NEMA11 2-phase stepper motor (0.67A / 6Ncm) with incremental encoder kit, resolution of 512lpr (32.768cpr), ABN, TTL  | 28 x 28 x 45    |
| QSH2818-51-07-012-8k | QSH2818-51-07-012-8192-AT | Motor + Encoder Module, NEMA11 2-phase stepper motor (0.67A / 12Ncm) with incremental encoder kit, resolution of 512lpr (32.768cpr), ABN, TTL | 28 x 28 x 64    |

*Table 1: Order codes*

Other encoder resolutions, signal output types, and customized motor options on request.



## 2 Motor Specifications and Characteristics

TRINAMIC's stepper motors are quality motors for universal use. They feature a long life due to ball bearings and no wearing out parts. These hybrid stepper motors are optimized for microstepping and give a good fit to the TRINAMIC family of motor controllers and drivers..

### 2.1 Technical and Mechanical Parameters

The main characteristics are:

- NEMA11 mounting configuration
- flange max. 28.0mm x 28.0mm
- 5mm axis diameter, 20mm axis length
- step angle: 1.8°
- optimized for microstep operation
- 4 wire connection
- CE approved

| Specifications                      | Unit              | QSH2818-32-07-006-8k | QSH2818-51-07-012-9k |
|-------------------------------------|-------------------|----------------------|----------------------|
| Rated Voltage                       | V                 | 3.8                  | 6.2                  |
| Rated Phase Current                 | A                 | 0.67                 | 0.67                 |
| Phase Resistance at 20°C            | Ω                 | 5.6                  | 9.2                  |
| Phase Inductance (typ.)             | mH                | 3.4                  | 7.2                  |
| Holding Torque (typ.)               | Ncm (oz in)       | 6 (8.5)              | 12 (17.0)            |
| Rotor Inertia                       | g cm <sup>2</sup> | 9                    | 18                   |
| Weight (Mass)                       | Kg                | 0.11                 | 0.2                  |
| Insulation Class                    |                   | B                    | B                    |
| Insulation Resistance               | Ω                 | 100M                 | 100M                 |
| Dialectic Strength (for one minute) | VAC               | 500                  | 500                  |
| Connection Wires                    |                   | 4                    | 4                    |
| Step Angle                          | °                 | 1.8                  | 1.8                  |
| Step angle Accuracy (max.)          | %                 | 5                    | 5                    |
| Flange Size (max.)                  | mm                | 28.0                 | 28.0                 |
| Motor Length (max.)                 | mm                | 32                   | 51                   |
| Axis Diameter                       | mm                | 5.0                  | 5.0                  |
| Axis Length (typ.)                  | mm                | 20.0                 | 20.0                 |
| Shaft Radial Play (450g load)       | mm                | 0.02                 | 0.02                 |
| Shaft Axial Play (450g load)        | mm                | 0.08                 | 0.08                 |



|  |         |           |           |
|--|---------|-----------|-----------|
| Maximum Radial Force (20 mm from front flange) | N       | 28        | 28        |
| Maximum Axial Force                            | N       | 10        | 10        |
| Ambient Temperature                            | °C      | -20...+50 | -20...+50 |
| Temp Rise (rated current, 2phase on)           | °C max. | 80        | max. 80   |
| Winding Thermal Time Constant                  | min     | 10        | 18        |
| Surface Thermal Time Constant                  | min     | 12        | 19        |

Table 2: Electrical and Mechanical Characteristics Motor

## 2.2 Torque-Speed Diagrams

The torque-speed figures detail motor torque characteristics measured in block commutation. Please be careful not to operate the motors outside the blue field. This is possible for short times only because of a resulting high coil temperature. The motors have insulation class B. The blue field is described by rated speed and rated torque.

### 2.2.1 QSH2818-32-07-006-8k

Testing conditions: Driver Supply 24V, 0.67A / Phase.

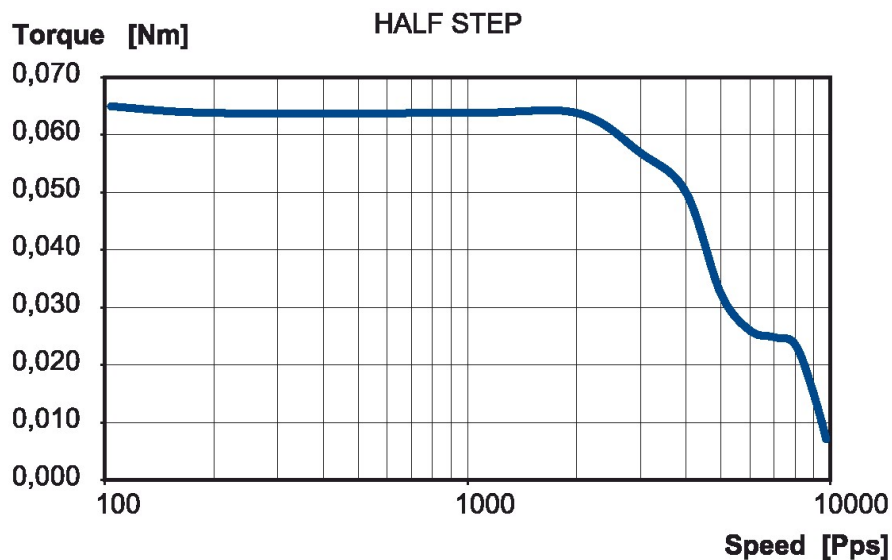

Figure 1: QSH2818-32-07-006-8k velocity vs. torque characteristic



### 2.2.2 QSH2818-51-07-012-8k

Testing conditions: Driver Supply 24V, 0.67A / Phase.

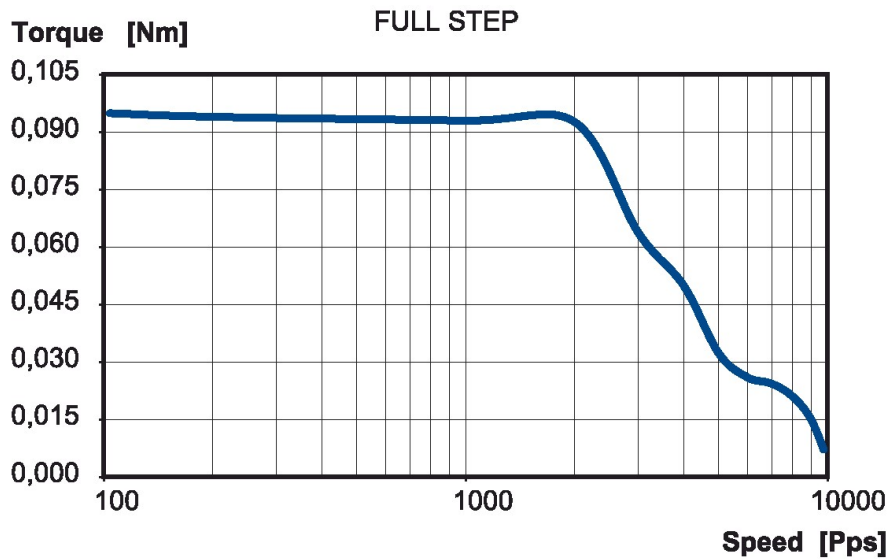

Figure 2: QSH2818-51-07-012-8k velocity vs. torque characteristics

## 3 Technical Specifications of the Encoders

### 3.1 Electrical Encoder Parameters

| Parameter           | Min | Typ    | Max  | Unit       |
|---------------------|-----|--------|------|------------|
| Supply voltage      | 4.5 | 5      | 5.5  | V          |
| Supply current      |     |        | 90   | mA         |
| Rise/fall time      |     |        | 10   | ns         |
| Frequency           |     |        | 1500 | kHz        |
| Output Voltage "H"  | 2.4 |        |      | V          |
| Input Voltage "L"   |     |        | 0.4  | V          |
| Max. output current |     |        | 5    | mA         |
| Disc lines          |     | 512    |      | lines      |
| Resolution          |     | 32.768 |      | increments |

Table 3: Electrical Characteristics Encoder



## 3.2 Mechanical Encoder Parameters

| Parameter                              | Min | Typ | Max  | Unit |
|--|-----|-----|------|------|
| Hollow Diameter (Symbol D in Drawings) |     | 4   |      | mm   |
| Starting Torque                        |     |     | 0.8  | Ncm  |
| Shaft Loading Axial                    |     |     | 25   | N    |
| Shaft Loading Radial                   |     |     | 40   | N    |
| Max. RPM                               |     |     | 6000 | rpm  |
| Net weight                             |     | 30  |      | g    |

Table 4: Mechanical Specifications

## 3.3 Environmental Encoder Parameters

| Parameter             | Description                |
|-----------------------|----------------------------|
| Operating Temperature | -20 – +85°C                |
| Storage Temperature   | -20 – +85°C                |
| Operating Humidity    | RH 85% max, non collecting |
| Shock                 | 490 $m/s^2$ , 3Dx2 times   |
| Vibration             | 1.2mm, 10-55kHz, 3Dx30min  |
| Protection            | IP40                       |

Table 5: Environmental Specifications

## 4 Connectors and Signals

### 4.1 Motor Connector

| Color | Wire Type    | Signal Name                  |
|-------|--------------|------------------------------|
| Black | UL1430 AWG26 | Coil A / Motor coil A pin 1  |
| Green | UL1430 AWG26 | Coil -A / Motor coil A pin 2 |
| Red   | UL1430 AWG26 | Coil B / Motor coil B pin 1  |
| Blue  | UL1430 AWG26 | Coil -B / Motor coil B pin 2 |

Table 7: Connector and signals of motor



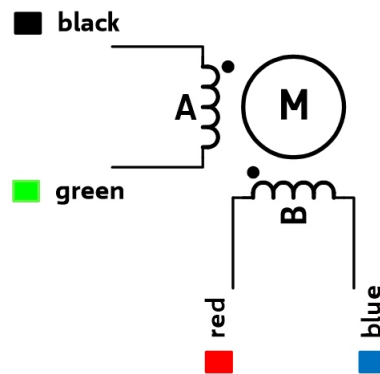

Figure 3: Lead wire configuration

## 4.2 Encoder Connector

| Pin Number | Color        | Wire Type         | Signal Name |
|------------|--------------|-------------------|-------------|
| 1          | Red          | UL2517 AWG28      | VCC         |
| 2          | Black        | UL2517 AWG28      | GND         |
| 3          | White        | UL2517 AWG28      | A+          |
| 4          | White/Black  | UL2517 AWG28Black | A-          |
| 5          | Green        | UL2517 AWG28      | B+          |
| 6          | Green/Black  | UL2517 AWG28      | B-          |
| 7          | Yellow       | UL2517 AWG28      | Z+          |
| 8          | Yellow/Black | UL2517 AWG28      | Z-          |
| 9          | Blue         | UL2517 AWG28      | Shield      |

Table 9: Connector and signals of the encoder

The required encoder cable connectors are:

- HSUAN MAO TECHNOLOGY CO., LTD.: H9010-XXPWSY00R, SH 1.0mm Housing 1XXXP White single row, ROHS, low lead
- HSUAN MAO TECHNOLOGY CO., LTD.: W9110-XXPBTWXSR, SH 1.0mm Wafer 1XXXP SMT Side Entry, type tin plated, white color, ROHS
- <http://www.hsm.net.tw/index.php>





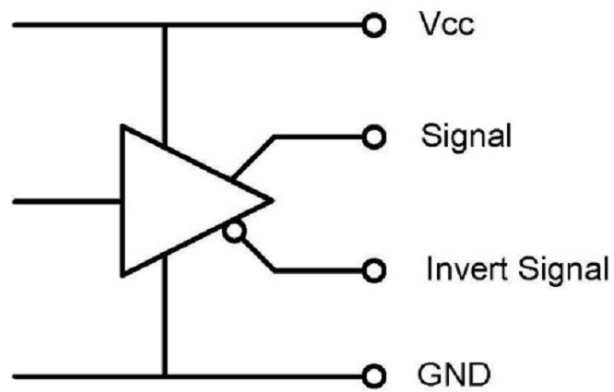

Figure 4: Connection and circuit diagram for the line driver outputs

### 4.3 Wave Form

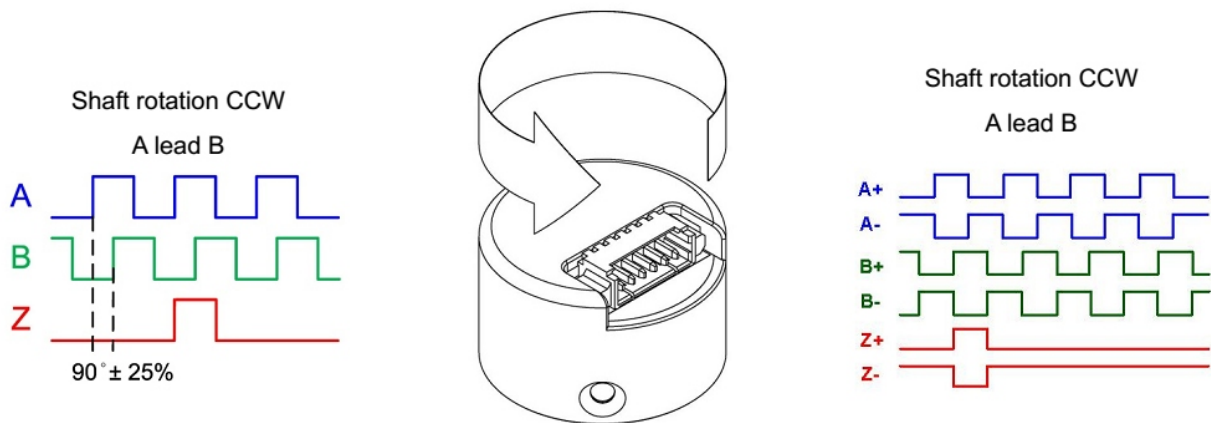

Figure 5: Example wave form for CCW rotation



## 5 Mechanical Drawings

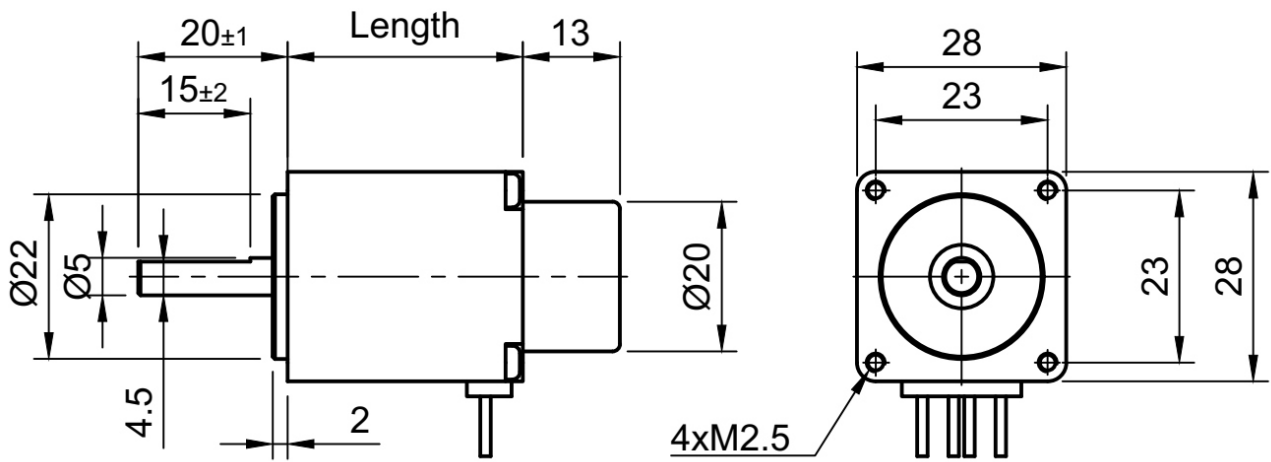

Figure 6: Dimensions of motor & encoder kit (all units = mm)

| Motor Type           | Body Length |
|----------------------|-------------|
| QSH2818-32-07-006-8k | 32mm        |
| QSH2818-51-07-012-8k | 51mm        |

Table 11: Motor length

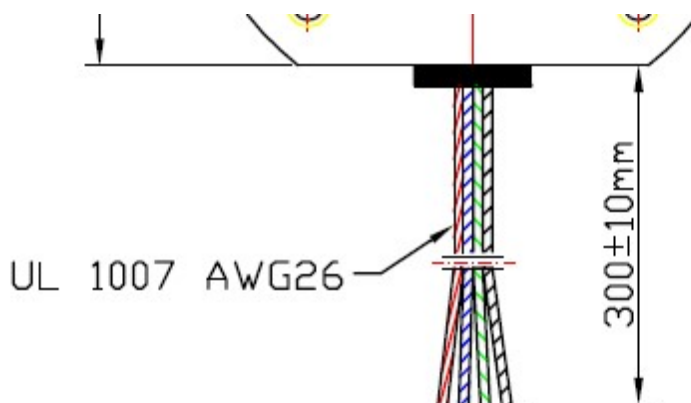

Figure 7: Length of motor wires/cables (all units = mm)



## 6 Considerations for Operation

The following sections try to help you to correctly set the key operation parameters in order to get a stable system.

### 6.1 Choosing the best Fitting Motor for an Application

For an optimum solution it is important to fit the motor to the application and to choose the best mode of operation. The key parameters are desired motor torque and velocity. While the motor holding torque describes the torque at stand-still, and gives a good indication for comparing different motors, it is not the key parameter for the best fitting motor. The required torque is a result of static load on the motor, dynamic loads which occur during acceleration/deceleration and loads due to friction. In most applications the load at maximum desired motor velocity is most critical, because of the reduction of motor torque at higher velocity. While the required velocity generally is well known, the required torque often is only roughly known. Generally, longer motors and motors with a larger diameter deliver a higher torque. But, using the same driver voltage for the motor, the larger motor earlier loses torque when increasing motor velocity. This means, that for a high torque at a high motor velocity, the smaller motor might be the better fitting solution.

Please refer to the torque vs. velocity diagram to determine the best fitting motor, which delivers enough torque at your desired velocities.

#### 6.1.1 Determining the Maximum Torque Required

Try a motor which should roughly fit. Take into consideration worst case conditions, i.e. minimum driver supply voltage and minimum driver current, maximum or minimum environment temperature (whichever is worse) and maximum friction of mechanics. Now, consider that you want to be on the safe side, and add some 10 percent safety margin taking into account unknown degradation of mechanics and motor.

### 6.2 Motor Current Settings

The motor torque is proportional to the motor current as long as the current stays at a reasonable level. At the same time, the power consumption of the motor (and driver) is proportional to the square of the motor current. Optimally, the motor should be chosen to bring the required performance at the rated motor current. For a short time, the motor current may be raised above this level in order to get increased torque, but care has to be taken in order not to exceed the maximum coil temperature of 130°C respectively a continuous motor operation temperature of 90°C.



| Percentage of rated current | Percentage of motor torque | Percentage of static motor power dissipation | Comment  |
|-----------------------------|----------------------------|--|--|
| 150%                        | ≤150%                      | 225%   | Limit operation to a few seconds   |
| 125%                        | 125%                       | 156%   | Operation possible for a limited time  |
| 100%                        | 100%                       | 100%<br>= $2 * I_{RMSRATED} * R_{COIL}$      | Normal operation   |
| 85%                         | 85%                        | 72%  | Normal operation   |
| 75%                         | 75%                        | 56%  | Normal operation   |
| 50%                         | 50%                        | 25%  | Reduced microstep exactness due to torque reducing in the magnitude of detent torque |
| 38%                         | 38%                        | 14%  | see above  |
| 25%                         | 25%                        | 6%   | see above  |
| 0%                          | see detent torque          | 0%   | Motor might lose position if the application's friction is too low                   |

Table 13: Motor current settings

### 6.2.1 Choosing the Optimum Current Setting

Generally, you choose the motor in order to give the desired performance at nominal current. For short time operation, you might want to increase the motor current to get a higher torque than specified for the motor. In a hot environment, you might want to work with a reduced motor current in order to reduce motor self heating.

The TRINAMIC drivers allow setting the motor current for up to three conditions:

- Stand still (choose a low current)
- Nominal operation (nominal current)
- High acceleration (if increased torque is required: You may choose a current above the nominal setting, but be aware, that the mean power dissipation shall not exceed the motors nominal rating)

If you reach the velocity limit, it might be a good idea to reduce the motor current, in order to avoid resonances occurring. Please refer to the information about choosing the driver voltage.

### 6.2.2 Choosing the Standby Current Setting

Most applications do not need much torque during motor stand-still. You should always reduce motor current during stand still. This reduces power dissipation and heat generation. Depending on your application, you typically at least can half power dissipation. There are several aspects why this is possible: In standstill, motor torque is higher than at any other velocity. Thus, you do not need the full current even



with a static load! Your application might need no torque at all, but you might need to keep the exact microstep position. Try how low you can go in your application. If the microstep position exactness does not matter for the time of standstill, you might even reduce the motor current to zero, provided that there is no static load on the motor and enough friction in order to avoid complete position loss.

### 6.3 Motor Driver Supply Voltage

The driver supply voltage in many applications cannot be chosen freely, because other components have a fixed supply voltage of e.g. 24V DC. If you have possibility to choose the driver supply voltage, please refer to the driver data sheet, and consider that a higher voltage means a higher torque at higher velocity. The motor torque diagrams are measured for a given supply voltage. You typically can scale the velocity axis (steps/sec) proportionally to the supply voltage to adapt the curve, e.g. if the curve is measured for 48V and you consider operation at 24V, half all values on the x-Axis to get an idea of the motor performance. For a chopper driver, consider the following corner values for the driver supply voltage (motor voltage). The table is based on the nominal motor voltage, which normally just has a theoretical background in order to determine the resistive loss in the motor.

Comment on the nominal motor voltage (please refer to motor technical data table):

$$U_{COILNOM} = I_{RMSRATED} * R_{COIL}$$

| Parameter                           | Value  | Comment   |
|-------------------------------------|--|---|
| Minimum driver supply voltage       | $2 * U_{COILNOM}$  | Very limited motor velocity. Only slow movement without torque reduction. Chopper noise might become audible.   |
| Optimum driver supply voltage       | $\geq 4 * U_{COILNOM}$<br>and<br>$\leq 22 * U_{COILNOM}$ | Choose the best fitting voltage in this range using the motor torque curve and the driver data. You can scale the torque curve proportionally to the actual driver supply voltage.                            |
| Maximum rated driver supply voltage | $25 * U_{COILNOM}$                                       | When exceeding this value, the magnetic switching losses in the motor reach a relevant magnitude and the motor might get too hot at nominal current. Thus there is no benefit in further raising the voltage. |

Table 15: Driver supply voltage considerations

#### 6.3.1 Determining if the Given Driver Voltage is Sufficient

Try to brake the motor and listen to it at different velocities. Does the sound of the motor get raucous or harsh when exceeding some velocity? Then the motor gets into a resonance area. The reason is that the motor back-EMF voltage reaches the supply voltage. Thus, the driver cannot bring the full current into the motor any more. This is typically a sign, that the motor velocity should not be further increased, because resonances and reduced current affect motor torque.

Measure the motor coil current at maximum desired velocity:



- For microstepping: If the waveform is still basically sinusoidal, the motor driver supply voltage is sufficient.
- For Fullstepping: If the motor current still reaches a constant plateau, the driver voltage is sufficient.

If you determine, that the voltage is not sufficient, you could either increase the voltage or reduce the current (and thus torque).

## 6.4 Back EMF (BEMF)

Within SI units, the numeric value of the BEMF constant has the same numeric value as the numeric value of the torque constant. For example, a motor with a torque constant of 1 Nm/A would have a BEMF constant of 1V/rad/s. Turning such a motor with 1 rps (1 rps = 1 revolution per second = 6.28 rad/s) generates a BEMF voltage of 6.28V.

The Back EMF constant can be calculated as:

$$U_{BEMF} = \frac{\text{Motor Holding Torque}}{2 * I_{NOM}}$$

The voltage is valid as RMS voltage per coil, thus the nominal current  $I_{NOM}$  is multiplied by 2 in this formula, since the nominal current assumes a full step position, with two coils switched on. The torque is in unit [Nm] where 1Nm = 100cNm = 1000mNm.

One can easily measure the BEMF constant of a two phase stepper motor with a (digital) scope. One just has to measure the voltage of one coil (one phase) when turning the axis of the motor manually. With this, one gets a voltage (amplitude) and a frequency of a periodic voltage signal (sine wave). The full step frequency is 4 times the frequency the measured sine wave.

## 6.5 Choosing the Commutation Scheme

While the motor performance curves are depicted for fullstepping and halfstepping, most modern drivers provide a microstepping scheme. Microstepping uses a discrete sine and a cosine wave to drive both coils of the motor, and gives a very smooth motor behavior as well as an increased position resolution. The amplitude of the waves is 1.41 times the nominal motor current, while the RMS values equal the nominal motor current. The stepper motor does not make loud steps any more – it turns smoothly! Therefore, 16 microsteps or more are recommended for a smooth operation and the avoidance of resonances. To operate the motor at fullstepping, some considerations should be taken into account.



| Driver Scheme   | Resolution                                | Velocity Range   | Torque   | Comment   |
|---|---|--|--|---|
| Fullstepping  | 200 steps per rotation                    | Low to very high. Skip resonance areas in low to medium velocity range | Full torque if dampener used, otherwise reduced torque in resonance area | Audible noise and vibrations especially at low velocities           |
| Halfstepping  | 200 steps per rotation * 2                | Low to very high. Skip resonance areas in low to medium velocity range | Full torque if dampener used, otherwise reduced torque in resonance area | Audible noise and vibrations especially at low velocities           |
| Microstepping   | 200 * (number of microsteps) per rotation | Low to high  | Reduced torque at very high velocity                                     | Low noise, smooth motor behavior                                    |
| Mixed: Microstepping and fullstepping for high velocities | 200 * (number of microsteps) per rotation | Low to very high   | Full torque  | At high velocities, there is no audible difference for fullstepping |

*Table 17: Comparing microstepping and fullstepping*

Microstepping gives the best performance for most applications and can be considered as state-of-the art. However, fullstepping allows some ten percent higher motor velocities, when compared to microstepping. A combination of microstepping at low and medium velocities and fullstepping at high velocities gives best performance at all velocities and is most universal. Most Trinamic driver modules support all three modes.

### 6.5.1 Fullstepping

When operating the motor in fullstep, resonances may occur. The resonance frequencies depend on the motor load. When the motor gets into a resonance area, it even might not turn anymore! Thus you should avoid resonance frequencies.

---

#### Note

Do not operate the motor at resonance velocities for extended periods of time. Use a reasonably high acceleration in order to accelerate to a resonance-free velocity. This avoids the build-up of resonances. When resonances occur at very high velocities, try reducing the current setting. A resonance dampener might be required, if the resonance frequencies cannot be skipped.

---



## 7 Figures Index

|   |  |   |   |  |    |
|---|--|---|---|--|----|
| 1 | QSH2818-32-07-006-8k velocity vs. torque characteristic . . . . .    | 5 | 5 | Example wave form for CCW rotation                           | 9  |
| 2 | QSH2818-51-07-012-8k velocity vs. torque characteristics . . . . .   | 6 | 6 | Dimensions of motor & encoder kit (all units = mm) . . . . . | 10 |
| 3 | Lead wire configuration . . . . .                                    | 8 | 7 | Length of motor wires/cables (all units = mm) . . . . .      | 10 |
| 4 | Connection and circuit diagram for the line driver outputs . . . . . | 9 |   |  |    |





## 8 Tables Index

|   |   |   |    |   |    |
|---|---|---|----|---|----|
| 1 | Order codes . . . . .                                     | 3 | 11 | Motor length . . . . .                              | 10 |
| 2 | Electrical and Mechanical Characteristics Motor . . . . . | 5 | 13 | Motor current settings . . . . .                    | 12 |
| 3 | Electrical Characteristics Encoder . . . . .              | 6 | 15 | Driver supply voltage considerations . . . . .      | 13 |
| 4 | Mechanical Specifications . . . . .                       | 7 | 17 | Comparing microstepping and full-stepping . . . . . | 15 |
| 5 | Environmental Specifications . . . . .                    | 7 | 18 | Hardware Revision . . . . .                         | 20 |
| 7 | Connector and signals of motor . . . . .                  | 7 | 19 | Document Revision . . . . .                         | 20 |
| 9 | Connector and signals of the encoder . . . . .            | 8 |    |   |    |



## 9 Supplemental Directives

### 9.1 Producer Information

### 9.2 Copyright

TRINAMIC owns the content of this user manual in its entirety, including but not limited to pictures, logos, trademarks, and resources. © Copyright 2021 TRINAMIC. All rights reserved. Electronically published by TRINAMIC, Germany.

Redistribution of sources or derived formats (for example, Portable Document Format or Hypertext Markup Language) must retain the above copyright notice, and the complete data sheet, user manual, and documentation of this product including associated application notes; and a reference to other available product-related documentation.

### 9.3 Trademark Designations and Symbols

Trademark designations and symbols used in this documentation indicate that a product or feature is owned and registered as trademark and/or patent either by TRINAMIC or by other manufacturers, whose products are used or referred to in combination with TRINAMIC's products and TRINAMIC's product documentation.

This Hardware Manual is a non-commercial publication that seeks to provide concise scientific and technical user information to the target user. Thus, trademark designations and symbols are only entered in the Short Spec of this document that introduces the product at a quick glance. The trademark designation /symbol is also entered when the product or feature name occurs for the first time in the document. All trademarks and brand names used are property of their respective owners.

### 9.4 Target User

The documentation provided here, is for programmers and engineers only, who are equipped with the necessary skills and have been trained to work with this type of product.

The Target User knows how to responsibly make use of this product without causing harm to himself or others, and without causing damage to systems or devices, in which the user incorporates the product.

### 9.5 Disclaimer: Life Support Systems

TRINAMIC Motion Control GmbH & Co. KG does not authorize or warrant any of its products for use in life support systems, without the specific written consent of TRINAMIC Motion Control GmbH & Co. KG.

Life support systems are equipment intended to support or sustain life, and whose failure to perform, when properly used in accordance with instructions provided, can be reasonably expected to result in personal injury or death.

Information given in this document is believed to be accurate and reliable. However, no responsibility is assumed for the consequences of its use nor for any infringement of patents or other rights of third parties which may result from its use. Specifications are subject to change without notice.

### 9.6 Disclaimer: Intended Use

The data specified in this user manual is intended solely for the purpose of product description. No representations or warranties, either express or implied, of merchantability, fitness for a particular purpose



or of any other nature are made hereunder with respect to information/specification or the products to which information refers and no guarantee with respect to compliance to the intended use is given.

In particular, this also applies to the stated possible applications or areas of applications of the product. TRINAMIC products are not designed for and must not be used in connection with any applications where the failure of such products would reasonably be expected to result in significant personal injury or death (safety-Critical Applications) without TRINAMIC's specific written consent.

TRINAMIC products are not designed nor intended for use in military or aerospace applications or environments or in automotive applications unless specifically designated for such use by TRINAMIC. TRINAMIC conveys no patent, copyright, mask work right or other trade mark right to this product. TRINAMIC assumes no liability for any patent and/or other trade mark rights of a third party resulting from processing or handling of the product and/or any other use of the product.

## 9.7 Collateral Documents & Tools

This product documentation is related and/or associated with additional tool kits, firmware and other items, as provided on the product page at: [www.trinamic.com](http://www.trinamic.com).



## 10 Revision History

### 10.1 Hardware Revision

| Version | Date       | Author | Description     |
|---------|------------|--------|-----------------|
| 1.00    | 24.01.2019 | TMC    | Initial release |

*Table 18: Hardware Revision*

### 10.2 Document Revision

| Version | Date       | Author | Description   |
|---------|------------|--------|---|
| 1.00    | 22.02.2019 | SK     | Initial release.  |
| 1.10    | 11.12.2019 | SK     | Motor wires type update to UL1430.  |
| 1.20    | 23.04.2020 | SK     | Overall lengths parameter corrected.  |
| 1.30    | 11.08.2020 | SK     | Lpr parameter updated. Motor cable length information added. Thermal time constant added. |
| 1.40    | 16.04.2021 | SK     | Order codes and naming updated.   |

*Table 19: Document Revision*

