

SNAP PAC Racks

Features

- ▶ Compatible with all SNAP PAC brains and R-series controllers, including Wired+Wireless™ models
- ▶ Secure mounting for SNAP I/O modules plus a SNAP brain or on-the-rack SNAP PAC controller
- ▶ Analog, digital, and serial modules on the same rack
- ▶ Panel or DIN-rail mounting
- ▶ Modules snap into place
- ▶ Factory Mutual-approved versions available

Description

SNAP PAC I/O mounting racks are designed to hold an intelligent SNAP I/O processor—a SNAP PAC EB-series or SB-series brain or a SNAP PAC R-series on-the-rack controller—and several I/O modules. Both standard wired controllers and brains and Wired+Wireless models are mounted on these racks.

Since SNAP analog, digital, and serial I/O modules all have the same footprint, customers using SNAP PAC racks can mix all these modules on the same I/O mounting rack. Field devices are wired directly to the top-mounted connectors on the modules plugged into each rack, or through breakout boards when additional wiring space is required. (See form 1756, the *SNAP TEX Cables and Breakout Boards Data Sheet*, for more information.)

SNAP PAC racks can accommodate up to 4, 8, 12, or 16 I/O modules. Part numbers ending in -FM are Factory Mutual approved.

The module and rack design allows modules to simply “snap” on the mounting rack.

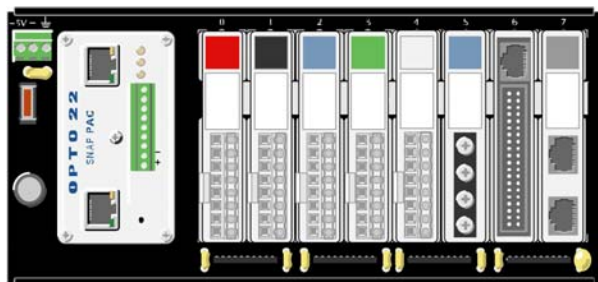

SNAP-PAC-RCK8 (8-Module Position I/O Mounting Rack)

Shown with SNAP-PAC-R1 controller and SNAP modules (all purchased separately)

SNAP PAC racks use a retention rail locking system that holds modules securely to the rack. Normally, a hold-down screw is not required. However, for applications that require additional

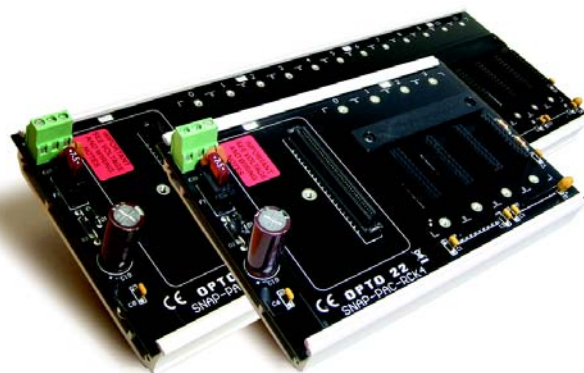

SNAP PAC Racks

module security, SNAP PAC racks have provisions for two 4–40 by 1/2-inch standard machine screws to hold each module in position.

All SNAP PAC racks offer panel mounting and the option of DIN-rail mounting. DIN-rail adapter part numbers are shown in the table below. For more information, see form 1772, the *SNAP TEX Mounting/Wiring Tools and Spare Parts Data Sheet*.

SNAP PAC racks require a 5 VDC power source. One power supply can usually power the rack, the I/O processor (controller or brain), and all modules on the rack. See form 1120, the *SNAP Power Supplies Data Sheet*, to choose a power supply.

Part Numbers

Part	Description
SNAP-PAC-RCK4	4-module SNAP PAC rack
SNAP-PAC-RCK4-FM	4-module SNAP PAC rack, Factory Mutual approved
SNAP-PAC-RCK8	8-module SNAP PAC rack
SNAP-PAC-RCK8-FM	8-module SNAP PAC rack, Factory Mutual approved
SNAP-PAC-RCK12	12-module SNAP PAC rack
SNAP-PAC-RCK12-FM	12-module SNAP PAC rack, Factory Mutual approved
SNAP-PAC-RCK16	16-module SNAP PAC rack
SNAP-PAC-RCK16-FM	16-module SNAP PAC rack, Factory Mutual approved
SNAP-FUSE7.5AB	7.5-amp fuse, 25 pack
SNAP-TEX-DRC10	SNAP rack DIN-rail adapter clip, 10-pack
SNAP-TEX-REC10W	Wide end cap for SNAP PAC racks DIN-rail assemblies, 10-pack
SNAP-TEX-REC10N	Narrow end cap for SNAP PAC racks DIN-rail assemblies, 10-pack

Specifications

Power ¹ Requirements	5.0 to 5.2 VDC @ 4.2 Amps max	
I/O Processor ² Compatibility	SNAP-PAC-R1 SNAP-PAC-R2 SNAP-PAC-EB1 SNAP-PAC-EB2 SNAP-PAC-R1-W SNAP-PAC-R2-W	SNAP-PAC-EB1-W SNAP-PAC-EB2-W SNAP-PAC-R1-FM SNAP-PAC-R2-FM SNAP-PAC-EB1-FM SNAP-PAC-EB2-FM
Replacement Fuse	SNAP-FUSE7.5AB or Littelfuse 297 07.5	
Rack Power Terminals Wire Size	22 to 14 AWG	
Operating Temperature	0 to 70 °C	
Relative Humidity	95%, non-condensing	
Agency Approvals	Non -FM models: UL, CE, RoHS, DFARS -FM models: FM, CE, RoHS, DFARS	
Warranty	30 months from date of manufacture	

1 Power requirements shown are for a rack, a processor, and a full load of analog modules. Power requirements for SNAP serial and high-density modules are higher. See module data sheets.
2 "I/O Processor" means a SNAP PAC brain or SNAP PAC on-the-rack controller. For compatibility with legacy Opto 22 products, see form #1693, *Legacy and Current Product Comparison and Compatibility Charts*.

Module Mating Connector Pinout (female)

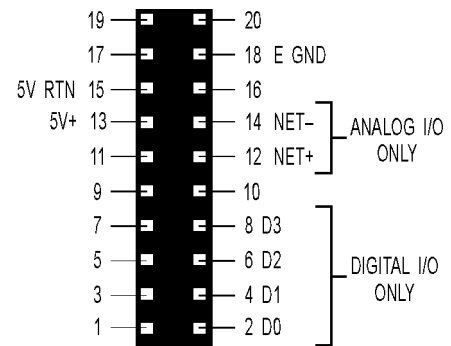

Power Schematic

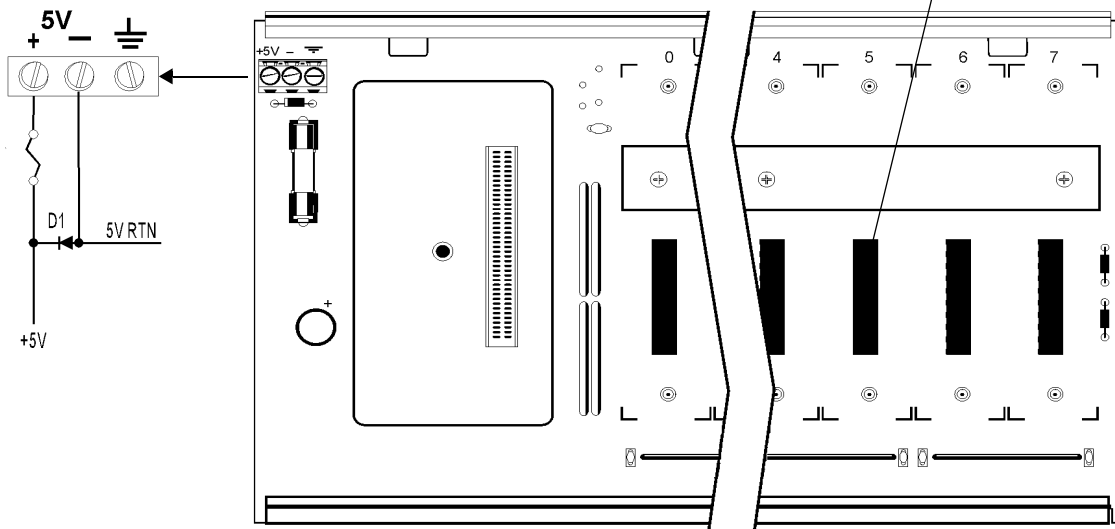

Notes on Grounding

Pin 18 E GND on each module (see diagram above right) is connected to the rack's GND. Module hold-down screws are also connected to the rack's GND.

The brain or rack-mounted controller is connected to the rack's GND through its center hold-down screw.

WARNING: EXPLOSION HAZARD. DO NOT DISCONNECT WHILE CIRCUIT IS LIVE UNLESS AREA IS KNOWN TO BE NON-HAZARDOUS.

AVERTISSEMENT: RISQUE D'EXPLOSION. NE PAS DÉBRANCHER TANT QUE LE CIRCUIT EST SOUS TENSION, À MOINS QU'IL NE S'AGISSE D'UN EMPLACEMENT NON DANGEREUX.

SNAP PAC Racks

Dimensional Drawings

Overall Dimensions

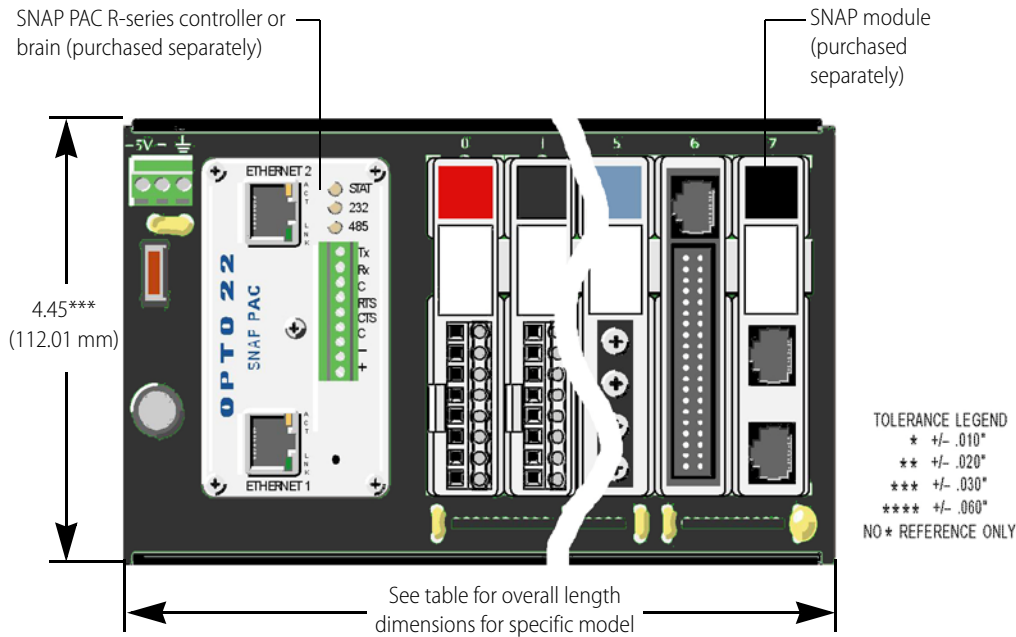

Overall Length Dimensions

Part Number	Description	Width (inches)	Width (mm)	Length (inches)	Length (mm)
SNAP-PAC-RCK4 SNAP-PAC-RCK4-FM	4-module rack	4.45	112.01	6.25	158.75
SNAP-PAC-RCK8 SNAP-PAC-RCK8-FM	8-module rack	4.45	112.01	9.25	234.95
SNAP-PAC-RCK12 SNAP-PAC-RCK12-FM	12-module rack	4.45	112.01	12.25	311.15
SNAP-PAC-RCK16 SNAP-PAC-RCK16-FM	16-module rack	4.45	112.01	15.25	387.35

Dimensional Drawings (continued)

Right Side View with DIN-Rail Option Installed

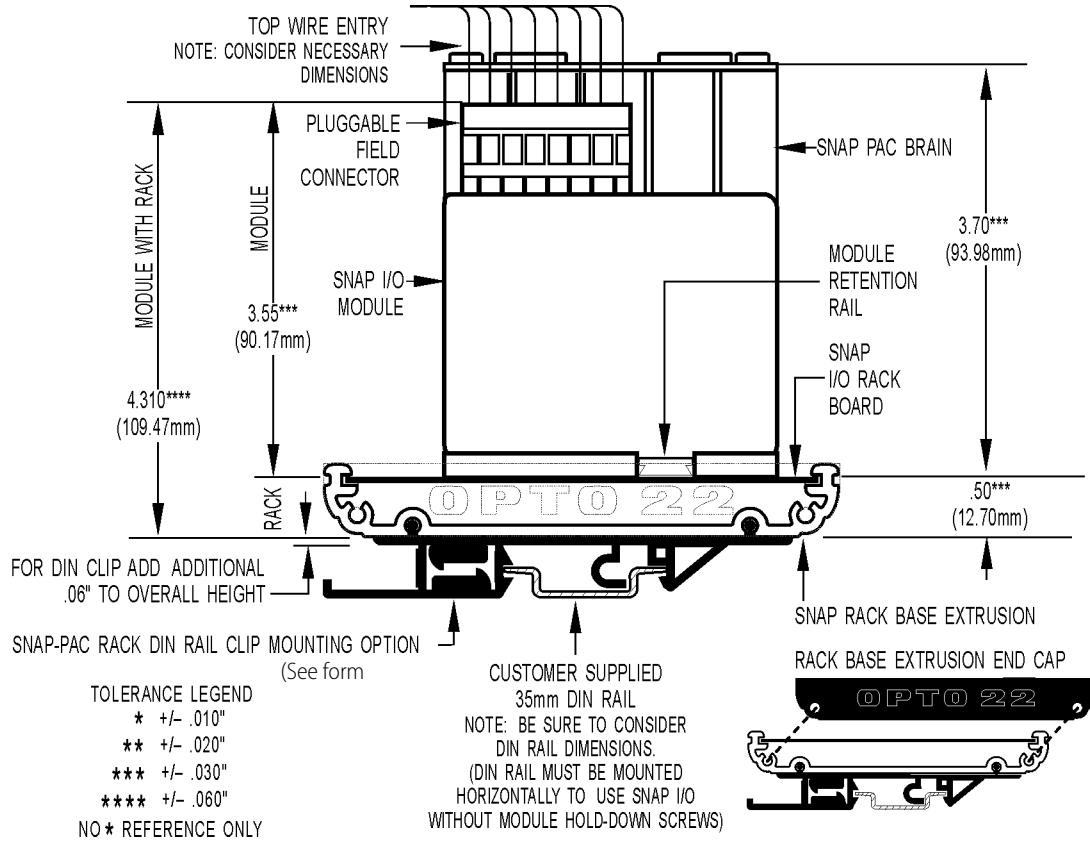

For more information on DIN-rail mounting kits, see form 1772, the *SNAP TEX Mounting/Wiring Tools and Spare Parts Data Sheet*.

SNAP PAC Racks

Mounting the Extrusion onto a Panel

NOTE: If you are not using hold-down screws, the SNAP PAC rack assembly should be mounted horizontally.

Use the following steps to mount a rack onto a panel. For DIN-rail mounting, see form #1772, the *SNAP TEX Mounting/Wiring and Spare Parts Data Sheet*.

Preferred Method: Template

(Product on site)

1. Use SNAP PAC rack mounting extrusion as template.
2. Use the diagram below to determine required product and option clearances.

Typical Plain View of SNAP Mounting Extrusion

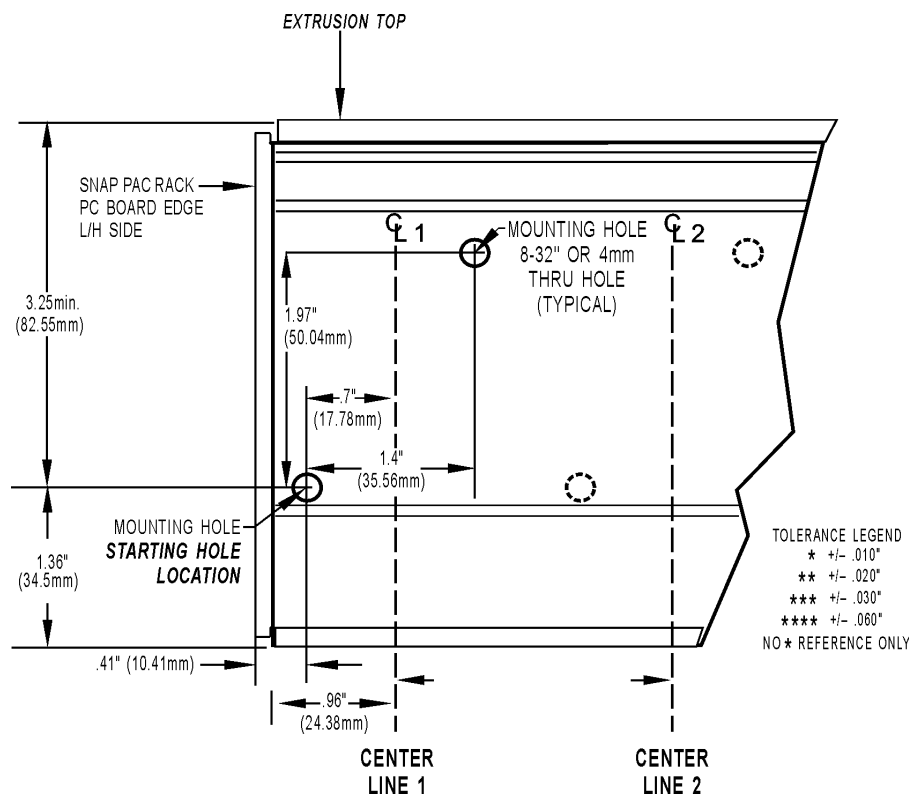

Center-to-Center Length (All Models)

Part Number	Description	Center-to-Center Length	Number of Center Positions
SNAP-PAC-RCK4 (or -FM)	4-module rack	4.02 in.	2
SNAP-PAC-RCK8 (or -FM)	8-module rack	3.51 in.	3
SNAP-PAC-RCK12 (or -FM)	12-module rack	5.01 in.	3
SNAP-PAC-RCK16 (or -FM)	16-module rack	4.34 in.	4

Alternate Method: Prefabrication of Panels

(No product on site)

Mounting holes are in sets of two, located on lower left and upper right with respect to a center line (CL).

1. Using the diagram below, determine CL1 mounting hole positions. (CL1 is located on the left side of all SNAP PAC rack mounting extrusions.)
2. Use the center-to-center length specification table below to determine the offset between center lines and the number of center line positions for each model.
3. Repeat the process for each center line position.

Assembling the Circuit Board, Rack Extrusion, and Din Clips,

1. (This step only for racks with three or more clips.) Slide one DIN clip to the middle position and secure with the rivet provided. For racks with four clips, add an additional middle clip.

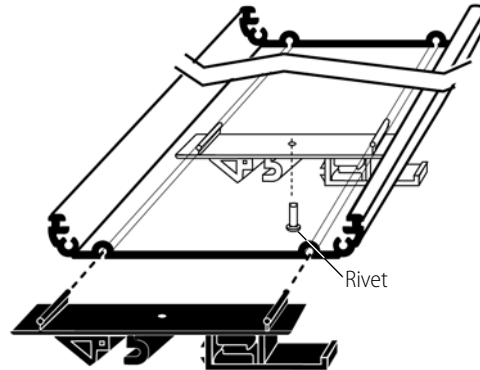

2. Insert one edge of the circuit board into the extrusion.

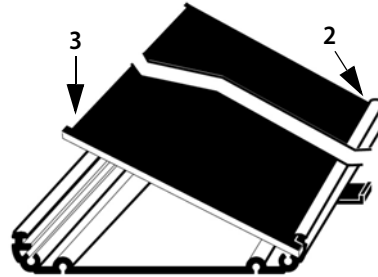

3. Push down hard on the other edge to snap the board into place.

4. Attach one DIN clip to each end cap using the slots in the end caps as shown.



5. Using the screws provided, secure an end cap and DIN clip assembly to each end of the extrusion.

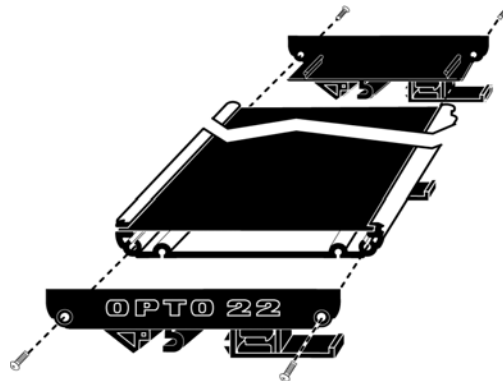

Removing the Circuit Board from the Rack Extrusion

If end caps are present, remove them. Then insert a flathead screwdriver in one of the circuit board release notches and pry up the board. Repeat in the other release notches until the board pops out of the extrusion.

More About Opto 22

Products

Opto 22 develops and manufactures reliable, flexible, easy-to-use hardware and software products for industrial automation, energy management, remote monitoring, and data acquisition applications.

OptoEMU Energy Management System

The easy-to-use OptoEMU Sensor monitors electrical energy use in your facility and delivers detailed, real-time data you can see and analyze. The Sensor can monitor energy data from pulsing meters, electrical panels or subpanels, and equipment. View energy data online using a software service or incorporate the data into your control system for complete energy management.

SNAP PAC System

Designed to simplify the typically complex process of selecting and applying an automation system, the SNAP PAC System consists of four integrated components:

- SNAP PAC controllers
- PAC Project™ Software Suite
- SNAP PAC brains
- SNAP I/O™

SNAP PAC Controllers

Programmable automation controllers (PACs) are multifunctional, modular controllers based on open standards.

Opto 22 has been manufacturing PACs for over two decades. The standalone SNAP PAC S-series and the rack-mounted SNAP PAC R-series both handle a wide range of digital, analog, and serial functions for data collection, remote monitoring, process control, and discrete and hybrid manufacturing.

SNAP PACs are based on open Ethernet and Internet Protocol (IP) standards, so you can build or extend a system easily, without the expense and limitations of proprietary networks and protocols.

PAC Project Software Suite

Opto 22's PAC Project Software Suite provides full-featured, cost-effective control programming, HMI (human machine interface) development and runtime, OPC server, and database connectivity software for your SNAP PAC System.

Control programming includes both easy-to-learn flowcharts and optional scripting. Commands are in plain English; variables and I/O point names are fully descriptive.

PAC Project Basic offers control and HMI tools and is free for download on our website, www.opto22.com. PAC Project Professional, available for separate purchase, adds

OptoOPCServer, OptoDataLink, options for controller redundancy or segmented networking, and support for legacy Opto 22 serial *mistic*™ I/O units.

SNAP PAC Brains

While SNAP PAC controllers provide central control and data distribution, SNAP PAC brains provide distributed intelligence for I/O processing and communications. Brains offer analog, digital, and serial functions, including thermocouple linearization; PID loop control; and optional high-speed digital counting (up to 20 kHz), quadrature counting, TPO, and pulse generation and measurement.

SNAP I/O

I/O provides the local connection to sensors and equipment. Opto 22 SNAP I/O offers 1 to 32 points of reliable I/O per module, depending on the type of module and your needs.

Analog, digital, and serial modules are all mixed on the same mounting rack and controlled by the same processor (SNAP PAC brain or rack-mounted controller).

Quality

Founded in 1974, Opto 22 has established a worldwide reputation for high-quality products. All are made in the U.S.A. at our manufacturing facility in Temecula, California. Because we do no statistical testing and each part is tested twice before leaving our factory, we can guarantee most solid-state relays and optically isolated I/O modules for life.

Free Product Support

Opto 22's California-based Product Support Group offers free, comprehensive technical support for Opto 22 products. Our staff of support engineers represents decades of training and experience. Support is available in English and Spanish by phone or email, Monday–Friday, 7 a.m. to 5 p.m. PST.

Additional support is always available on our website: how-to videos, OptoKnowledgeBase, self-training guide, troubleshooting and user's guides, and OptoForums.

In addition, hands-on training is available for free at our Temecula, California headquarters, and you can [register online](#).

Purchasing Opto 22 Products

Opto 22 products are sold directly and through a worldwide network of distributors, partners, and system integrators. For more information, contact Opto 22 headquarters at 800-321-6786 or 951-695-3000, or visit our website at www.opto22.com.

www.opto22.com