

56 mm sq. (2.20 inch sq.)

1.8° /step RoHS

Unipolar winding, Lead wire type
Bipolar winding, Lead wire type ▶ p. 70

Customizing

- Hollow Shaft modification
- Decelerator Encoder

Varies depending on the model number and quantity. Contact us for details.

Unipolar winding, Lead wire type

Model number		Holding torque at 2-phase energization	Rated current	Wiring resistance	Winding inductance	Rotor inertia	Mass (Weight)	Motor length (L)
Single shaft	Dual shaft	[N·m (oz·in) min.]	A/phase	Ω /phase	mH/phase	[× 10 ⁻⁴ kg·m ² (oz·in ²)]	[kg (lbs)]	mm (in)
103H7121-0140	103H7121-0110	0.39 (55.2)	1	4.8	8	0.1 (0.55)	0.47 (1.04)	41.8 (1.65)
103H7121-0440	103H7121-0410	0.39 (55.2)	2	1.25	1.9	0.1 (0.55)	0.47 (1.04)	41.8 (1.65)
103H7121-0740	103H7121-0710	0.39 (55.2)	3	0.6	0.8	0.1 (0.55)	0.47 (1.04)	41.8 (1.65)
103H7123-0140	103H7123-0110	0.83 (117.5)	1	6.7	15	0.21 (1.15)	0.65 (1.43)	53.8 (2.12)
103H7123-0440	103H7123-0410	0.83 (117.5)	2	1.6	3.8	0.21 (1.15)	0.65 (1.43)	53.8 (2.12)
103H7123-0740	103H7123-0710	0.78 (110.5)	3	0.77	1.58	0.21 (1.15)	0.65 (1.43)	53.8 (2.12)
103H7124-0140	103H7124-0110	0.98 (138.8)	1	7	14.5	0.245 (1.34)	0.8 (1.76)	63.8 (2.51)
103H7124-0440	103H7124-0410	0.98 (138.8)	2	1.7	3.1	0.245 (1.34)	0.8 (1.76)	63.8 (2.51)
103H7124-0740	103H7124-0710	0.98 (138.8)	3	0.74	1.4	0.245 (1.34)	0.8 (1.76)	63.8 (2.51)
103H7126-0140	103H7126-0110	1.27 (179.8)	1	8.6	19	0.36 (1.97)	0.98 (2.16)	75.8 (2.98)
103H7126-0440	103H7126-0410	1.27 (179.8)	2	2	4.5	0.36 (1.97)	0.98 (2.16)	75.8 (2.98)
103H7126-0740	103H7126-0710	1.27 (179.8)	3	0.9	2.2	0.36 (1.97)	0.98 (2.16)	75.8 (2.98)

Characteristics diagram

103H7121-0140 103H7121-0110

Constant current circuit
Source voltage: 24 VDC
Operating current:
1 A/phase, 2-phase
energization (full-step)
 $J_L=[0.94 \times 10^{-4} \text{kg}\cdot\text{m}^2$ (5.14
oz·in²) use the rubber
coupling]
fs: Maximum self-start
frequency when not
loaded

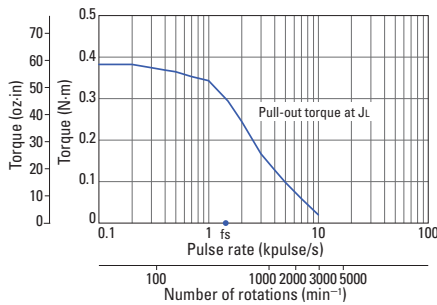

103H7121-0440 103H7121-0410

Constant current circuit
Source voltage: 24 VDC
Operating current:
2 A/phase, 2-phase
energization (full-step)
 $J_L=[0.94 \times 10^{-4} \text{kg}\cdot\text{m}^2$ (5.14
oz·in²) use the rubber
coupling]
fs: Maximum self-start
frequency when not
loaded

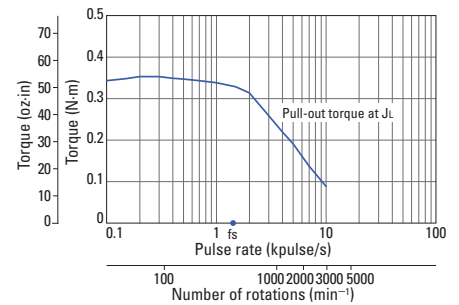

103H7121-0740 103H7121-0710

Constant current circuit
Source voltage: 24 VDC
Operating current:
3 A/phase, 2-phase
energization (full-step)
 $J_L=[0.94 \times 10^{-4} \text{kg}\cdot\text{m}^2$ (5.14
oz·in²) use the rubber
coupling]
fs: Maximum self-start
frequency when not
loaded

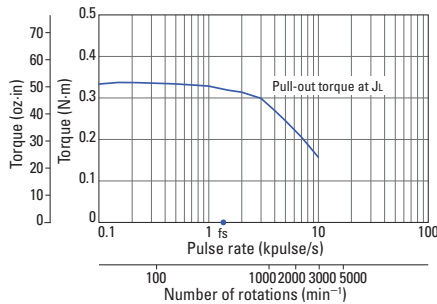

103H7123-0140 103H7123-0110

Constant current circuit
Source voltage: 24 VDC
Operating current:
1 A/phase, 2-phase
energization (full-step)
 $J_L=[0.94 \times 10^{-4} \text{kg}\cdot\text{m}^2$ (5.14
oz·in²) use the rubber
coupling]
fs: Maximum self-start
frequency when not
loaded

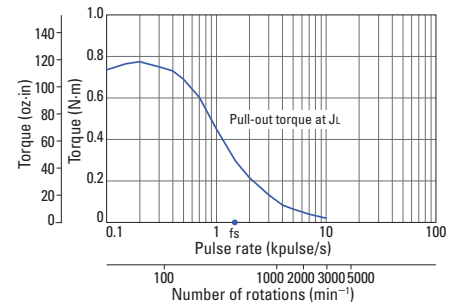

103H7123-0440 103H7123-0410

Constant current circuit
Source voltage: 24 VDC
Operating current:
2 A/phase, 2-phase
energization (full-step)
 $J_L=[0.94 \times 10^{-4} \text{kg}\cdot\text{m}^2$ (5.14
oz·in²) use the rubber
coupling]
fs: Maximum self-start
frequency when not
loaded

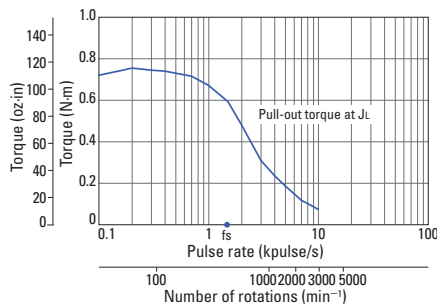

103H7123-0740 103H7123-0710

Constant current circuit
Source voltage: 24 VDC
Operating current:
3 A/phase, 2-phase
energization (full-step)
 $J_L=[0.94 \times 10^{-4} \text{kg}\cdot\text{m}^2$ (5.14
oz·in²) use the rubber
coupling]
fs: Maximum self-start
frequency when not
loaded

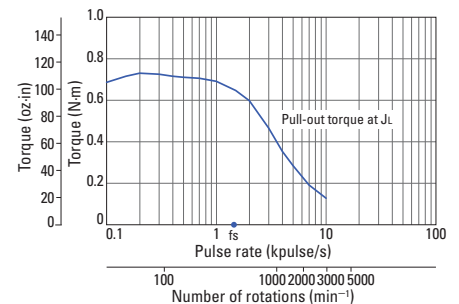

Characteristics diagram

103H7124-0140 103H7124-0110

Constant current circuit
Source voltage: 24 VDC
Operating current:
1 A/phase, 2-phase
energization (full-step)
 $J_L = [2.6 \times 10^{-4} \text{kg}\cdot\text{m}^2$ (14.22
oz-in²) use the rubber
coupling]
fs: Maximum self-start
frequency when not
loaded

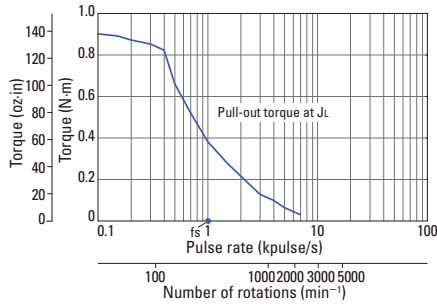

103H7124-0440 103H7124-0410

Constant current circuit
Source voltage: 24 VDC
Operating current:
2 A/phase, 2-phase
energization (full-step)
 $J_L = [2.6 \times 10^{-4} \text{kg}\cdot\text{m}^2$ (14.22
oz-in²) use the rubber
coupling]
fs: Maximum self-start
frequency when not
loaded

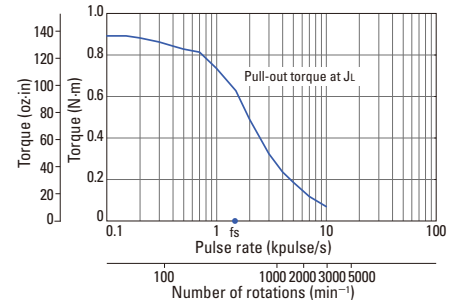

103H7124-0740 103H7124-0710

Constant current circuit
Source voltage: 24 VDC
Operating current:
3 A/phase, 2-phase
energization (full-step)
 $J_L = [2.6 \times 10^{-4} \text{kg}\cdot\text{m}^2$ (14.22
oz-in²) use the rubber
coupling]
fs: Maximum self-start
frequency when not
loaded

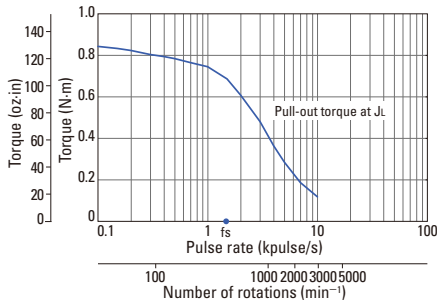

103H7126-0140 103H7126-0110

Constant current circuit
Source voltage: 24 VDC
Operating current:
1 A/phase, 2-phase
energization (full-step)
 $J_L = [2.6 \times 10^{-4} \text{kg}\cdot\text{m}^2$ (14.22
oz-in²) use the rubber
coupling]
fs: Maximum self-start
frequency when not
loaded

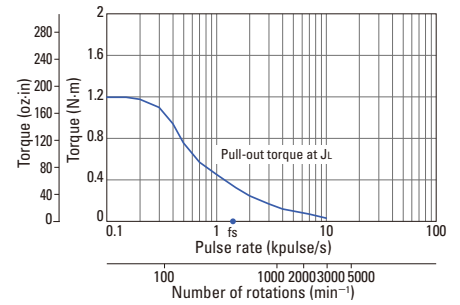

103H7126-0440 103H7126-0410

Constant current circuit
Source voltage: 24 VDC
Operating current:
2 A/phase, 2-phase
energization (full-step)
 $J_L = [2.6 \times 10^{-4} \text{kg}\cdot\text{m}^2$ (14.22
oz-in²) use the rubber
coupling]
fs: Maximum self-start
frequency when not
loaded

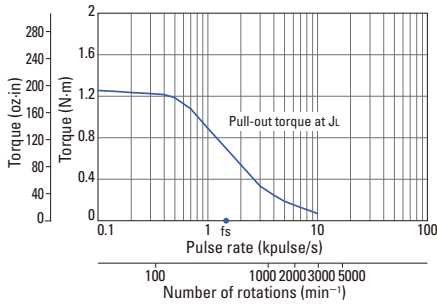

103H7126-0740 103H7126-0710

Constant current circuit
Source voltage: 24 VDC
Operating current:
3 A/phase, 2-phase
energization (full-step)
 $J_L = [2.6 \times 10^{-4} \text{kg}\cdot\text{m}^2$ (14.22
oz-in²) use the rubber
coupling]
fs: Maximum self-start
frequency when not
loaded

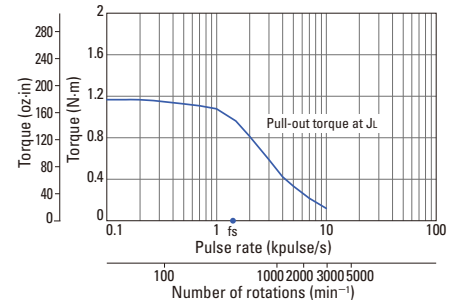

Dimensions [Unit: mm (inch)]

Lead wire: UL1430 (103H7121, 103H7124, 103H7126), AWG22
UL3266 (103H7123), AWG22

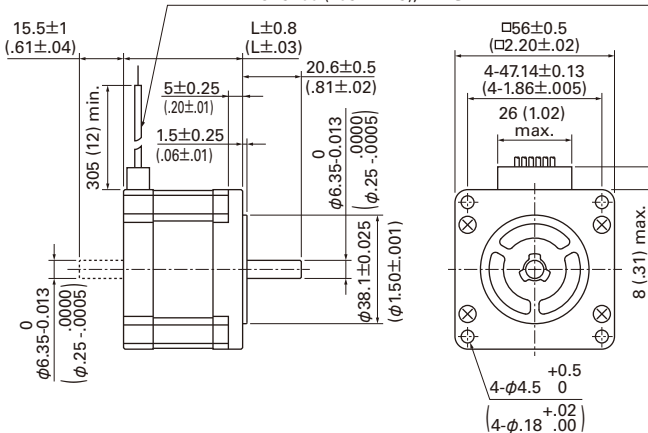

Internal wiring

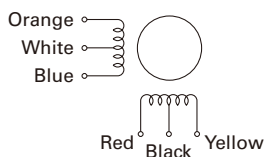

Compatible drivers

- For motor model number 103H712 □ -01 □ 0 (1 A/phase), 103H712 □ -07 □ 0 (3 A/phase)

Driver is not included.

If you require assistance finding a driver, contact us for details.

- For model number 103H712 □ -04 □ 0 (2 A/phase)

Model number: US1D200P10 (DC input)

Operating current select switch setting: 0

The characteristics diagram shown above is from our experimental circuit.

Allowable Radial/Thrust Load

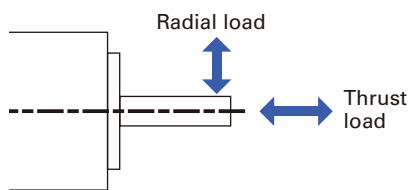

Flange size	Model number	Distance from end of shaft : mm (in)				Thrust load N (lbs)
		0	5	10	15	
Radial load : N (lbs)						
14 mm sq. (0.55 in sq.)	SH2141	10 (2.25)	11 (2.47)	13 (2.92)	-	0.7 (0.16)
28 mm sq. (1.10 in sq.)	SH228 □	42 (9)	48 (10)	56 (12)	66 (14)	3 (0.67)
35 mm sq. (1.38 in sq.)	SH353 □	40 (8)	50 (11)	67 (15)	98 (22)	10 (2.25)
42 mm sq. (1.65 in sq.)	103H52 □□ SH142 □	22 (4)	26 (5)	33 (7)	46 (10)	10 (2.25)
50 mm sq. (1.97 in sq.)	103H670 □	71 (15)	87 (19)	115 (25)	167 (37)	15 (3.37)
56 mm sq. (2.20 in sq.)	103H712 □	52 (11)	65 (14)	85 (19)	123 (27)	15 (3.37)
	103H7128	85 (19)	105 (23)	138 (31)	200 (44)	15 (3.37)
60 mm sq. (2.36 in sq.)	103H782 □	70 (15)	87 (19)	114 (25)	165 (37)	20 (4.50)
	SH160 □					15 (3.37)
86 mm sq. (3.39 in sq.)	SM286 □ SH286 □	167 (37)	193 (43)	229 (51)	280 (62)	60 (13.488)
	103H822 □					191 (43)
φ 106 mm (φ 4.17 in)	103H8922 □	321 (72)	356 (79)	401 (90)	457 (101)	100 (22.48)

Internal Wiring and Rotation Direction

Unipolar winding

Connector type Model number: 103H52 □□

Internal wire connection

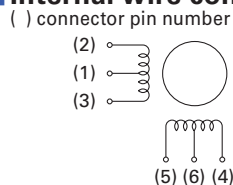

Direction of motor rotation

When excited by a direct current in the order shown below, the direction of rotation is clockwise as viewed from the output shaft side.

Exciting order	Connector pin number				
	(1.6)	(5)	(3)	(4)	(2)
1	+	-	-	-	-
2	+	-	-	-	-
3	+	-	-	-	-
4	+	-	-	-	-

Connector type Model number: 103H782 □□

Internal wire connection

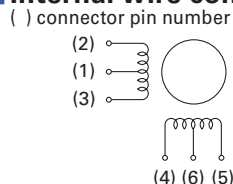

Direction of motor rotation

When excited by a direct current in the order shown below, the direction of rotation is clockwise as viewed from the output shaft side.

Exciting order	Connector pin number				
	(1.6)	(4)	(3)	(5)	(2)
1	+	-	-	-	-
2	+	-	-	-	-
3	+	-	-	-	-
4	+	-	-	-	-

Lead wire type

Internal wire connection

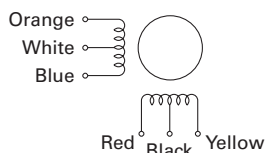

Direction of motor rotation

When excited by a direct current in the order shown below, the direction of rotation is clockwise as viewed from the output shaft side.

Exciting order	Lead wire color				
	White & black	Red	Blue	Yellow	Orange
1	+	-	-	-	-
2	+	-	-	-	-
3	+	-	-	-	-
4	+	-	-	-	-

Bipolar winding

Connector type

Internal wire connection

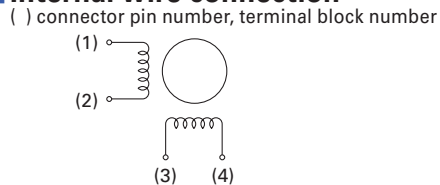

Direction of motor rotation

When excited by a direct current in the order shown below, the direction of rotation is clockwise as viewed from the output shaft side.

Exciting order	Connector pin number, terminal block number			
	(3)	(2)	(4)	(1)
1	-	-	+	+
2	+	-	-	+
3	+	+	-	-
4	-	+	+	-

Lead wire type

Internal wire connection

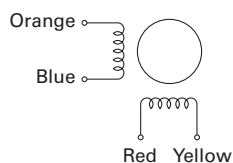

Direction of motor rotation

When excited by a direct current in the order shown below, the direction of rotation is clockwise as viewed from the output shaft side.

Exciting order	Lead wire color			
	Red	Blue	Yellow	Orange
1	-	-	+	+
2	+	-	-	+
3	+	+	-	-
4	-	+	+	-

General Specifications

Motor model number	SH2141	SH228 □	SH353 □	SS242 □	SH142 □	103H52 □□	SS250 □	103H67 □□	103H712 □
Type	-								
Operating ambient temperature	- 10°C to + 50°C								
Conversation temperature	- 20°C to + 65°C								
Operating ambient humidity	20 to 90% RH (no condensation)								
Conversation humidity	5 to 95% RH (no condensation)								
Operation altitude	1000 m (3281 feet) max. above sea level								
Vibration resistance	Vibration frequency 10 to 500 Hz, total amplitude 1.52 mm (10 to 70 Hz), vibration acceleration 150 m/s ² (70 to 500 Hz), sweep time 15 min/cycle, 12 sweeps in each X, Y and Z direction.								
Impact resistance	500 m/s ² of acceleration for 11 ms with half-sine wave applying three times for X, Y, and Z axes each, 18 times in total.								
Insulation class	Class B (+130°C)								
Withstandable voltage	At normal temperature and humidity, no failure with 500 VAC @50/60 Hz applied for one minute between motor winding and frame.						At normal temperature and humidity, no failure with 1000 VAC @50/60 Hz applied for one minute between motor winding and frame.		
Insulation resistance	At normal temperature and humidity, not less than 100 MΩ between winding and frame by 500 VDC megger.								
Protection grade	IP40								
Winding temperature rise	80 K max. (Based on Sanyo Denki standard)								
Static angle error	± 0.09°				± 0.054°		± 0.09°		
Thrust play *1	0.075 mm (0.003 in) max. (load: 0.35 N (0.08 lbs))	0.075 mm (0.003 in) max. (load: 1.5 N (0.34 lbs))	0.075 mm (0.003 in) max. (load: 5 N (1.12 lbs))	0.075 mm (0.003 in) max. (load: 4 N (0.9 lbs))	0.075 mm (0.003 in) max. (load: 5 N (1.12 lbs))	0.075 mm (0.003 in) max. (load: 5 N (1.12 lbs))	0.075 mm (0.003 in) max. (load: 4 N (0.9 lbs))	0.075 mm (0.003 in) max. (load: 10 N (2.25 lbs))	0.075 mm (0.003 in) max. (load: 10 N (2.25 lbs))
Radial play *2	0.025 mm (0.001 in) max. (load: 5 N (1.12 lbs))								
Shaft runout	0.025 mm (0.001 in)								
Concentricity of mounting pilot relative to shaft	φ 0.05 mm (φ 0.002 in)	φ 0.05 mm (φ 0.002 in)	φ 0.075 mm (φ 0.003 in)	φ 0.075 mm (φ 0.003 in)	φ 0.05 mm (φ 0.002 in)	φ 0.05 mm (φ 0.002 in)	φ 0.075 mm (φ 0.003 in)	φ 0.075 mm (φ 0.003 in)	φ 0.075 mm (φ 0.003 in)
Squareness of mounting surface relative to shaft	0.1 mm (0.004 in)	0.1 mm (0.004 in)	0.1 mm (0.004 in)	0.1 mm (0.004 in)	0.1 mm (0.004 in)	0.1 mm (0.004 in)	0.1 mm (0.004 in)	0.1 mm (0.004 in)	0.1 mm (0.004 in)
Direction of motor mounting	Can be freely mounted vertically or horizontally								

Motor model number	SH160 □	103H78 □□	SH286 □	103H8922 □	SM286 □	103H712 □ -6 □□ 0 CE Model	103H822 □ -6 □□ 0 CE Model	103H8922 □ -63 □ 1 CE Model	
Type	-				S1 (continuous operation)				
Operating ambient temperature	- 10°C to + 50°C				- 10°C to + 40°C				
Conversation temperature	- 20°C to + 65°C				- 20°C to + 60°C				
Operating ambient humidity	20 to 90% RH (no condensation)				95% max.: 40°C max., 57% max.: 50°C max., 35% max.: 60°C max. (no condensation)				
Conversation humidity	5 to 95% RH (no condensation)								
Operation altitude	1000 m (3280 feet) max. above sea level								
Vibration resistance	Vibration frequency 10 to 500 Hz, total amplitude 1.52 mm (10 to 70 Hz), vibration acceleration 150 m/s ² (70 to 500 Hz), sweep time 15 min/cycle, 12 sweeps in each X, Y and Z direction.								
Impact resistance	500 m/s ² of acceleration for 11 ms with half-sine wave applying three times for X, Y and Z axes each, 18 times in total.								
Insulation class	Class B (+130°C)				Class F (+155°C)		Class B (+130°C)		
Withstandable voltage	At normal temperature and humidity, no failure with 1000 VAC @50/60 Hz applied for one minute between motor winding and frame.				At normal temperature and humidity, no failure with 1500 VAC @50/60 Hz applied for one minute between motor winding and frame.				
Insulation resistance	At normal temperature and humidity, not less than 100 MΩ between winding and frame by 500 VDC megger.								
Protection grade	IP40				IP43				
Winding temperature rise	80 K max. (Based on Sanyo Denki standard)								
Static angle error	± 0.054°		± 0.09°						
Thrust play *1	0.075 mm (0.003 in) max. (load: 10 N (2.25 lbs))								
Radial play *2	0.025 mm (0.001 in) (load: 5 N (1.12 lbs))	0.025 mm (0.001 in) (load: 5 N (1.12 lbs))	0.025 mm (0.001 in) (load: 5 N (1.12 lbs))	0.025 mm (0.001 in) (load: 10 N (2.25 lbs))	0.025 mm (0.001 in) (load: 5 N (1.12 lbs))	0.025 mm (0.001 in) (load: 5 N (1.12 lbs))	0.025 mm (0.001 in) (load: 5 N (1.12 lbs))	0.025 mm (0.001 in) (load: 10 N (2.25 lbs))	
Shaft runout	0.025 mm (0.001 in)								
Concentricity of mounting pilot relative to shaft	φ 0.075 mm (φ 0.003 in)								
Squareness of mounting surface relative to shaft	0.1 mm (0.004 in)	0.075 mm (0.003 in)	0.15 mm (0.006 in)	0.1 mm (0.004 in)	0.15 mm (0.006 in)	0.075 mm (0.003 in)	0.1 mm (0.004 in)	0.1 mm (0.004 in)	
Direction of motor mounting	Can be freely mounted vertically or horizontally								

*1 Thrust play: Shaft displacement under axial load.

*2 Radial play: Shaft displacement under radial load applied 1/3rd of the length from the end of the shaft.

Safety standards

Model Number: **SM286** □ CE/UL marked models

CE (TÜV)	Standard category	Applicable standard	
	Low-voltage directives	EN60034-1, EN60034-5	
UL	Acquired standards	Applicable standard	File No.
	UL	UL1004-1, UL1004-6	E179832
	UL for Canada	CSA C22.2 No.100	

Model Number: **103H712** □ -6 □□ 0, **103H822** □ -6 □□ 0, **103H8922** □ -63 □ 1 CE marked model

CE (TÜV)	Standard category	Applicable standard	
	Low-voltage directives	EN60034-1, EN60034-5	

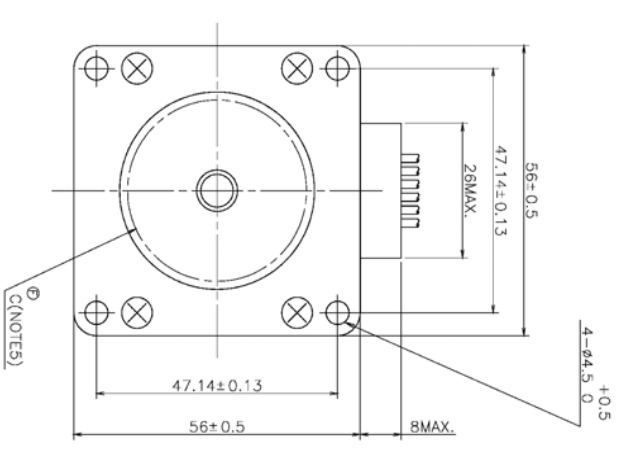
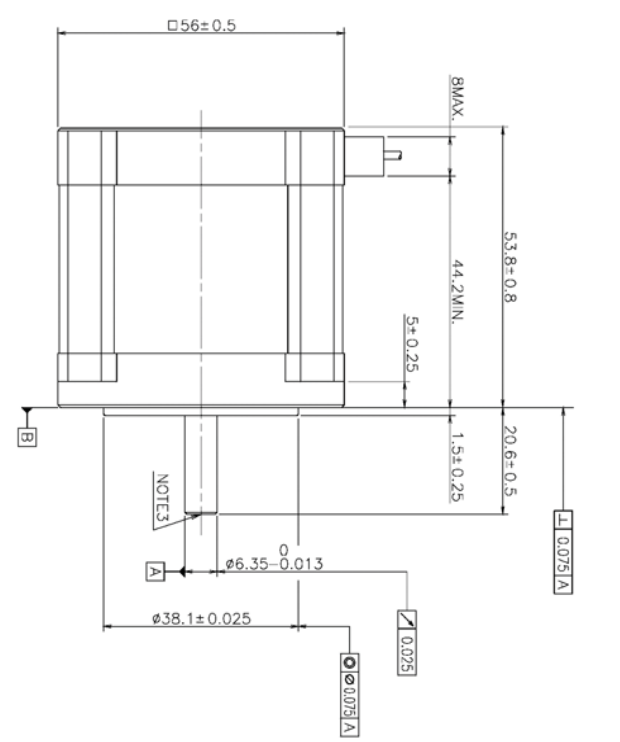
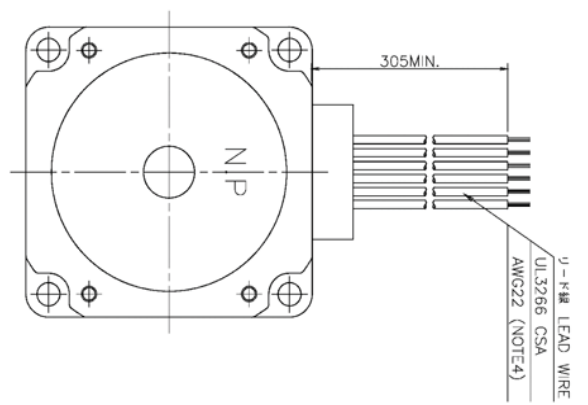

定格特性・RATED CHARACTERISTICS

相数	2
基本スロット角	1.8°
FUNDAMENTAL STEP ANGLE	1.8°
定格電圧	6.7 V(DC)
VOLTS	6.7 V(DC)
定格電流	1 A/PHASE
AMPS	1 A/PHASE
巻線抵抗	6.7 Ω±10% at 25℃
WINDING RESISTANCE	6.7 Ω±10% at 25℃
巻線インダクタンス	15 mH±20% at 1 kHz 1 V(rms)
WINDING INDUCTANCE	15 mH±20% at 1 kHz 1 V(rms)
ホールアウトトルク	0.83 N·m MIN. at 1 A/PHASE 2 PHASE EXCITATION
HOLDING TORQUE	0.83 N·m MIN. at 1 A/PHASE 2 PHASE EXCITATION
注1. 駆出トルク	0.57 N·m MIN. at 200 pulse/s
NOTE1. PULL OUT TORQUE	0.57 N·m MIN. at 200 pulse/s
	負荷イナーシャ
	INERTIAL LOAD 0.94x10 ⁻⁴ kg·m ²
	(ラバーカップリングを含む)
	(INERTIA OF RUBBER COUPLING IS INCLUDED.)
注1. 最大自起動脈流数	1100 pulse/s MIN. at NO LOAD
NOTE1. MAX. STARTING RATE	1100 pulse/s MIN. at NO LOAD
注1. 最大連続回転速度数	1550 pulse/s MIN. at NO LOAD
NOTE1. MAX. SLEWING RATE	1550 pulse/s MIN. at NO LOAD
静止角度精度	±0.054° (0.108° SPREAD MAX.) 2 PHASE EXCITATION
POSITIONAL ACCURACY	±0.054° (0.108° SPREAD MAX.) 2 PHASE EXCITATION
注2. 温度上昇値	80 K MAX.
NOTE2. COIL TEMPERATURE RISE	80 K MAX.
ローインertia	0.21x10 ⁻⁴ kg·m ² NOMINAL
ROTOR INERTIA	0.21x10 ⁻⁴ kg·m ² NOMINAL
絶縁等級	B
INSULATION CLASS	B
許容ラスタト重量	15 N
ALLOWABLE THRUST LOAD	15 N
許容ラスタル径	71 N
ALLOWABLE RADIAL LOAD	71 N
	軸先端部重量
	LOAD TO SHAFT END.

注1. 山洋機軸の相励磁駆動回路による。
 NOTE1. SANYO STANDARD 2 PHASE EXCITATION DRIVE CIRCUIT WAS USED.
 2. 160x160のラスタス部板に取付け、2相励磁=1 A/相を連続駆動し、逐次法にて測定した時の値。
 2. 160x160 of rasts board to be attached, 2 phase excitation = 1 A/phase continuously energized a coil at 2 phase excitation, = 1 A/phase. MEASURED BY THE CHANGE OF RESISTANCE METHOD.
 3. シフトセンター穴の有無及び形状は、製造上の都合により任意とする。
 3. SHIFT CENTER HOLE ON THE SHAFT END IS NOT ALWAYS MADE.
 4. ミニターミナル接続口部の配色は任意とする。
 4. A COLOR SCHEME OF LEAD WIRE OF MOTOR'S OUTLET IS DISCRETION.
 5. 部品の形状は、製造上の都合により任意とする。
 5. THE SHAPE OF INSIDE OF C IS DISCRETION BY THE REASON IN MANUFACTURE.

内部接続 CONNECTION

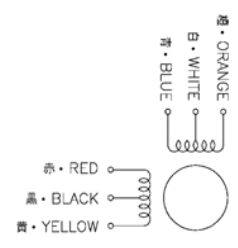

回転方向・DIRECTION OF ROTATION

下記の順に相励磁した場合、回転方向は断面図より見て時計方向回転のこと。
 WHEN A MOTOR IS SEQUENCED AS SHOWN IN THE TABLE BELOW, THE SHAFT ROTATION MUST BE CLOCKWISE WHEN YOU SEE FROM SURFACE "B" SIDE.

励磁順序	1	2	3	4
励磁順序	+	+	+	+
励磁順序	-	-	-	-
励磁順序	+	-	-	+
励磁順序	-	+	+	-

励磁順序	1	2	3	4
励磁順序	+	+	+	+
励磁順序	-	-	-	-
励磁順序	+	-	-	+
励磁順序	-	+	+	-

山洋電気株式会社
 SANYO DENKI CO., LTD.
 103H7123-0140
 18 00021245