

COVERING

Elastic rubber, hardness 70 Shore A

WHEEL CENTRE BODY

Pressure die-cast aluminium.

ROLLING ACTION

Hub with ball bearings. Ideal solution for heavy loads and continuous moving.

APPLICATIONS

Wear and tearing resistance. For selection parameters see Technical data (on page 1701).

RE.G2 wheels are also supplied with steel sheet bracket for medium-heavy loads RE.G2-H (see page 1688).

ENVIRONMENTAL CONDITIONS

Suitable for use in humid environments and in the presence of medium-aggressive chemical environments; use in environments with the presence of organic, chlorinated solvents, hydrocarbons and mineral oils is not recommended.

ROLLING RESISTANCE - FORCE / LOAD APPLIED

The diagram shows the force to be applied to a wheel to keep it moving at the constant speed of 4 km/h, according to the applied load. The intersection point with a 50N value is the maximum transportable load with a manually actuated 4-wheel trolley; in fact, 200N = 50N x 4 wheels is the maximum force that may be supported by the operator according to the regulations in force regarding work safety.

MECHANICAL MOVING WITH TOWING DEVICES

For mechanical towing, please see the technical specifications to determine the capacity variation.

TEMPERATURE

If operating temperatures in an application differ from the standard range of values, please see the technical specifications to determine the capacity variation.

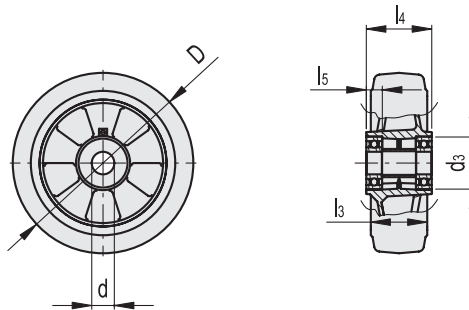
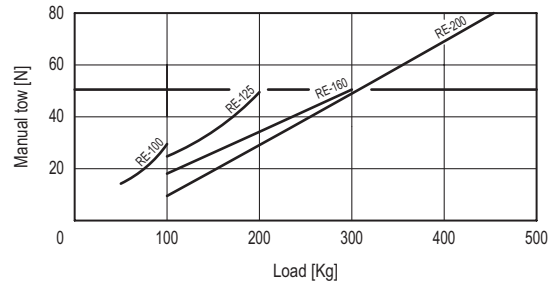

Code	Description	D	d	d3	l3	l4	l5	Static load# [N]	Rolling resistance# [N]	Dynamic carrying capacity# [N]	⚖️
452771	RE.G2-100-RSL	100	15	32	40	40	9	2500	1800	1800	440
452772	RE.G2-125-RSL	125	20	47	50	59	14	3200	2300	2300	840
452773	RE.G2-160-RSL	160	20	47	50	59	14	4200	3000	3000	1220
452774	RE.G2-200-RSL	200	20	52	50	60	17.5	10000	3000	5000	2000

For static load, rolling resistance and dynamic carrying capacity see Technical data (on page 1704).

