

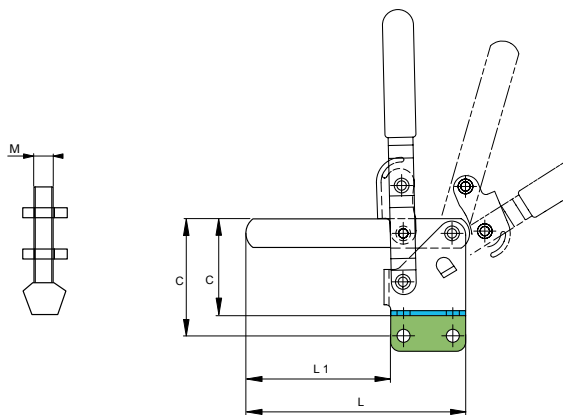

Series HV 550

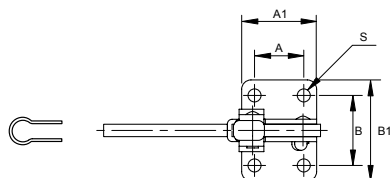
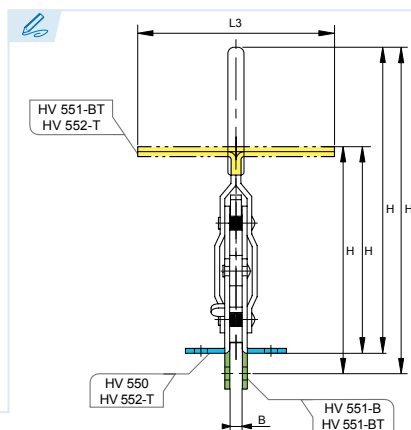

Brazo vertical, apriete vertical
Vertical handle, hold down action
Poignée verticale, action de retenue
Braço vertical, aperto vertical

Remaches en acero inoxidable
Stainless steel rivets
Rivets en acier inoxydable
Rebites em aço inoxidável

Empuñadura: termoplástico color rojo
Embossed red handle grip provided
Poignée rouge embossée fournie
Punho: termoplástico de cor vermelha

· Bridas con brazo de presión macizo (el cuerpo es idéntico a la serie HV 650). Suministradas con tornillo para ajuste de presión con contra de neopreno.

· Solid bar clamps (series HV550 and HV650 share identical bodies). Supplied with neoprene tipped hex-head spindle assemblies.

· Sauterelles à bras plein (les corps des series HV550 et HV650 sont identiques). Fourni avec un axe en nylon tête hexagonale.

· Garras com braço de pressão maciço (o corpo é idêntico à série HV 650). Fornecidas com parafuso para ajuste de pressão com ponteira de neoprene.

ES EN FR PT

Modelo
Model
Modèle
Modelo

F_{max}. Fuerza de sujeción
Holding capacity
Capacité de serrage
Força de fixação

A. E. Ángulo de empuñadura
Handle moves
Rotation de la poignée
Ângulo de punho

A. B. Ángulo de brazo
Bar moves
Rotation de la bride
Ângulo do braço

gr. Peso
Weight
Poids
Peso

| Ref. | Modelo | A | A1 | B | B1 | C | H | L | L1 | L3 | M | S | F _{max} | gr. | A. E. | A. B. | |
|------|------------|------------------|------|------|------|------|------|-----|-------|----|-----|------------|------------------|--------|-------|-------|------|
| JL | KKHV-550 | HV 550 | 31,8 | 48,4 | 45,2 | 65,2 | 42,9 | 199 | 139,4 | 91 | - | M10 (x1,5) | 8,4 | 340 Kg | 660 | 58° | 106° |
| II | KKHV-551B | HV 551-B | 31,8 | 48,4 | 8,0 | - | 55,6 | 212 | 139,4 | 91 | - | M10 (x1,5) | 8,4 | 340 Kg | 660 | 58° | 106° |
| II T | KKHV-551BT | HV 551-BT | 31,8 | 48,4 | 8,0 | - | 55,6 | 154 | 139,4 | 91 | 127 | M10 (x1,5) | 8,4 | 340 Kg | 660 | 58° | 106° |
| JL T | KKHV-552T | HV 552-T | 31,8 | 48,4 | 45,2 | 65,2 | 42,9 | 141 | 139,4 | 91 | 127 | M10 (x1,5) | 8,4 | 340 Kg | 660 | 58° | 106° |