

Adapter for MSC-D, 16 A

Part no. MSFAD-16
Catalog No. 191096
Eaton Catalog No. MSFD-16



Delivery program

Product range			Accessories
Accessories			Busbar adapters
			Approved to UL 508
Rated operational voltage	U_e	V	690
Rated operational current	I_e	A	16
Terminal capacity			AWG 14 (2.5 mm ²)
Adapter width		mm	45
Adapter length		mm	160
DIN rail		Quantity	1
For use with			MSC-D, 16 A

Technical data ETIM 6.0

Low-voltage industrial components (EG000017) / Busbar adapter (EC001531)			
Electric engineering, automation, process control engineering / Low-voltage switch technology / Busbar trunking system (LV circuitry) / Busbar adapter (low-voltage switching technology) (ecl@ss8.1-27-37-03-04 [ACN951008])			
Mounting rail armament			1 mounting rail
Type of electrical connection			Round conductor
Rated current I_n		A	16
Min. busbar thickness		mm	2
Max. busbar thickness		mm	2
Width of the adapter		mm	45
Rail width		mm	24
Busbar distance		mm	60

Dimensions

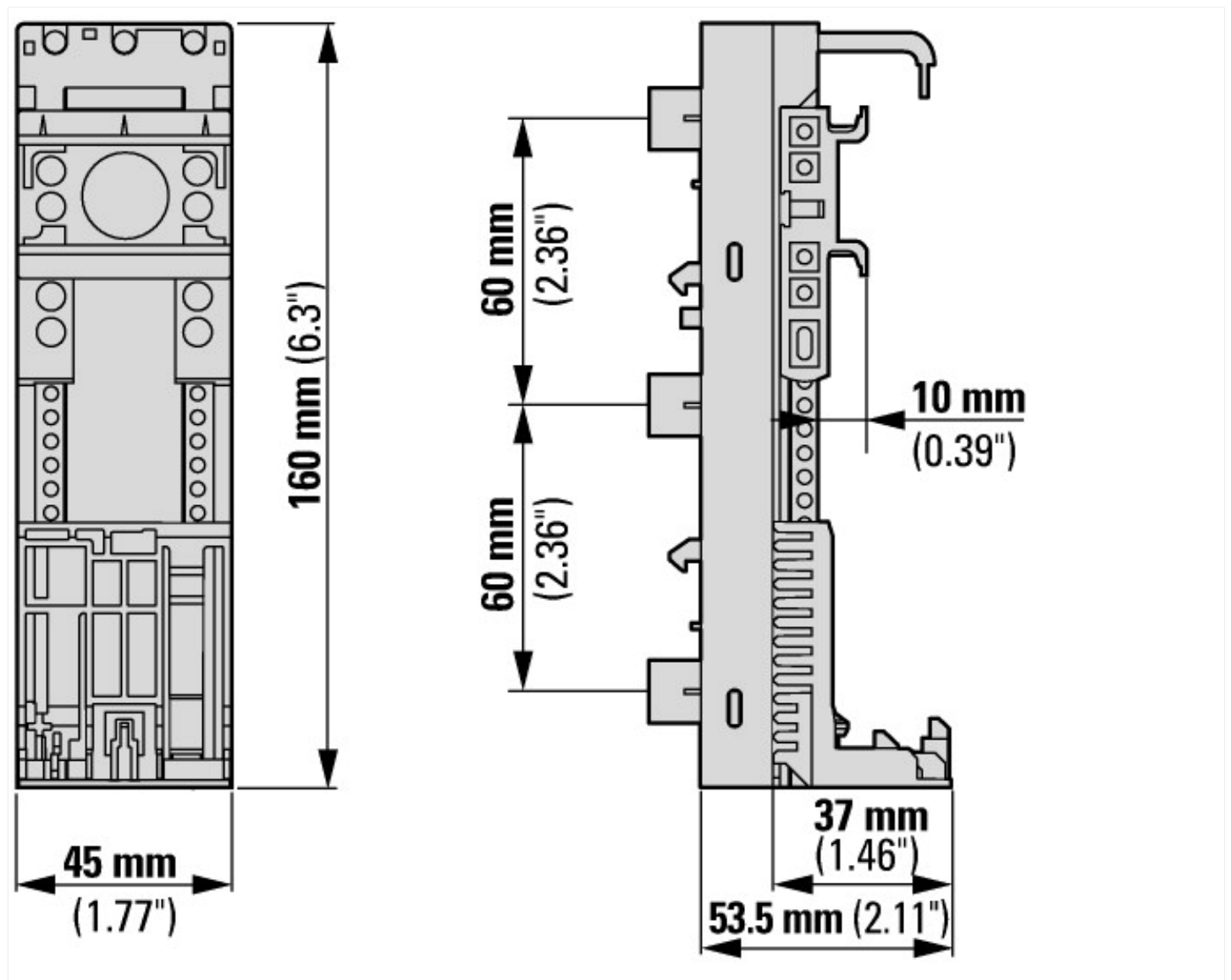

Additional product information (links)

IL015082ZU Adapter

IL015082ZU Adapter ftp://ftp.moeller.net/DOCUMENTATION/AWA_INSTRUCTIONS/IL015082ZU2017_05.pdf

Motor starters and "Special Purpose Ratings" for the North American market http://www.moeller.net/binary/ver_techpapers/ver953en.pdf

Busbar Component Adapters for modern Industrial control panels http://www.moeller.net/binary/ver_techpapers/ver960en.pdf