

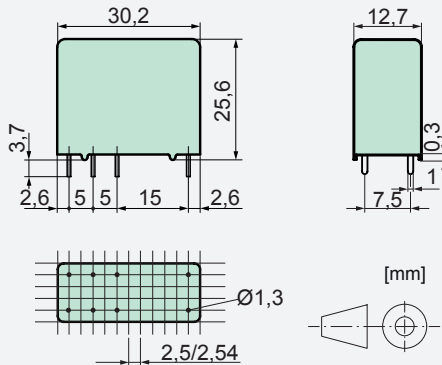

Relay Key Data

- PCB Relay with forcibly guided contacts
- Protective separation between coil and contacts (leakage and creepage distances >14 mm); protective separation diagonally between left and right contact side (leakage and creepage distances >5,5 mm)
- EN50205 type B
- 2 CO contacts with notched crown
- Nominal coil power 0,7 W
- Holding Power 0,21 W

Dimensions



Contact Data

Contact material	AgCuNi + 0,2 µm AU
Type of contact	notched crown
Rated switching capacity	250 VAC 8 A AC1 2000 VA
Electr. life AC 1(360 cycles / h)	approx. 100000
Inrush current max.	15 A for 20 ms
Switching voltage range	5 to 250 VDC / VAC
Switching current range*	4 mA to 8 A
Switching capacity range*	50 mW to 2000 W(VA)
Contact resistance (as delivered)	≤100 mΩ / 28 V / 100 mA

*Guided values

Standard coils for direct current

(other voltages on request)

Nominal voltage VDC	Min. pick-up voltage at 20 °C	Drop-out voltage at 20 °C	Nominal current in mA	Resistance in Ohm at 20 °C
5	3,75	≥0,5	140,0	35,7 ± 10%
6	4,5	≥0,6	116,0	51,4 ± 10%
12	9,0	≥1,2	58,5	205 ± 10%
18	13,5	≥1,8	38,9	462 ± 10%
24	18,0	≥2,4	29,1	822 ± 10%
48	36,0	≥4,8	14,5	3290 ± 10%
60	45,0	≥6,0	11,6	5140 ± 13%
110	82,5	≥11,0	6,3	17280 ± 15%

Circuit Diagram (view on relay upper side)

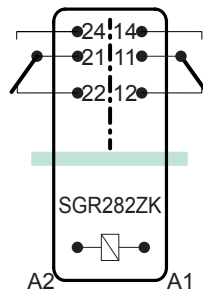

Insulation Data

- Double or reinforced insulation	at 250 VAC
- Air and creepage distance	>5,5 mm
- Test voltage	4000 V / 50 Hz / 1 min
- Double or reinforced insulation	at 250 VAC
- Air and creepage distance	>14 mm
- Test voltage	5000 V / 50 Hz / 1 min
Test voltage contact open	1500 V / 50 Hz / 1 min
Creepage resistance	CTI 550
Pollution degree	2
Overvoltage category	III
Insulation resistance at Up 500 VDC	>100 MΩ

Additional Data

Mechanical endurance	>10 x 10 ⁶ operations
Switching frequency, mechanical	15 Hz
Response time (all NO closed)	typically 12 ms
Drop-out time** (all NC closed)	typically 5 ms
Bounce time of NO contact	typically 4 ms
Bounce time of NC contact	typically 8 ms
Shock resistance 16 ms	NO > 10g NC > 2,5g
Vibration resistance (10-55 Hz)	NO > 10g NC > 1,5g
Resistance to short circuiting	
NO	1000 A SCPD 10 A gG / gL (pre-fuse)
NC	1000 A SCPD 6 A gG / gL (pre-fuse)
Ambient temperature	-40°C to +70°C
Thermal resistance	50 K / W
Temperature limit for coil	120°C
Weight	ca. 20 g
Mounting position	any
Type of protection	RT II
Solder bath temperature	270°C / 5 s

**without spark suppression

Tests, Regulations

Approvals



UL File E188953	Sec. 1
Insulation class IEC 60664-1	250 VAC
Fire protection requirements	UL 94 / V1

Options, Accessories

PCB socket, DIN rail socket
Various modules

Product Key

SGR282ZK 24VDC
Coil voltage
Type designation

Contact Lifetime for NO Contacts

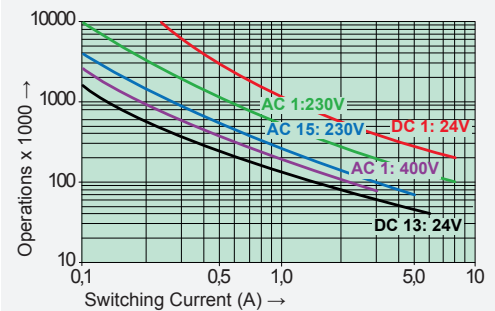

Maximal switching characteristics (DIN EN60947-5-1, Tab. C2)

AC 15:	230 V / 5 A
DC 13:	24 V / 6 A
UL 508:	C300

Maximal contact load at AC 1 with 230 V:
2 contacts with 8 A each

Load Limit Curve with Direct Current

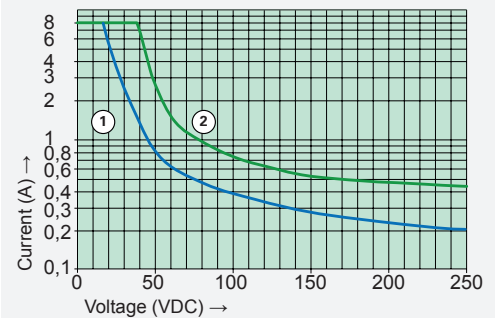

- 1) Inductive load L/R 40 ms
- 2) Resistive load

Excitation Voltage Range

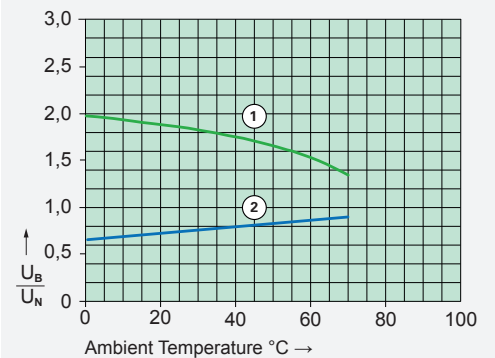

- 1) Max. excitation voltage with contact load: <4 A
- 2) Min. excitation voltage (guaranteed values) without previous operation

No heat accumulation due to intrinsic heating of other components. Continuous duty 100%.