



# DIN Signal female connector



### General information

Design	IEC 60603-2	types: B, 2B, 3B, C, 2C, 3C, M female		
No. of contacts	max. 96			
Contact spacing	2,54 mm			
Test voltage	1000V			
Contact resistance	max. 20mOhm			
Insulation resistance	min. 10 <sup>9</sup> Ohm			
Working current	2A at 20°C (see derating diagram)	40 A for type M		
Temperature range	-55°C ... +125°C			
	-40°C ... +105°C (for press-in connectors)			
Termination technology	press-in, solder pins			
Clearance & creepage distance	min. 1,2 mm each			
Insertion and withdrawal force	16-pole max. 15N	20-pole max. 20N	30-pole max. 30N	32-pole max. 30N
	48-pole max. 45N	64-pole max. 60N	96-pole max. 90N	
Mating cycles	acc. to performance level, see table below			
UL file	E102079			
RoHS - compliant	Yes			
Leadfree	Yes			
Hot plugging	No			

### Insulator material

Material	PBT (thermoplastics, glass fiber reinforcement 30%)			
Color	RAL 7032 (grey)			
UL classification	UL 94-V0			
Material group acc. IEC 60664-1	IIIa (175 < CTI < 400)			
NFF classification	I3, F4			

### Contact material

Contact material	Copper alloy			
Plating termination zone	Sn over Ni for solder, Ni for press-in			
Plating contact zone I	acc. to performance level, see table below			
Plating contact zone II (termination side)	acc. to performance level, see table below			

performance level	mating cycles		plating contact zone	
	acc. to IEC 60603-2	complementary acc. to IEC 60603-2	plating contact zone I	plating contact zone II (termination side)
1	500		<i>Au over PdNi over Ni</i>	
2	400		<i>Au over PdNi over Ni</i>	
3	50		<i>Au over Ni</i>	
NM30 (S4)		500	min. 0,76µm (30pinch) noble metal (alloy) over Ni	
Au1	500		Au over Ni	
Au2	400		Au over Ni	
Au30		500	min. 0,76µm (30pinch) Au over Ni	
Au50		500	min. 1,27µm (50pinch) Au over Ni	
Au70		500	min. 1,60µm (70pinch) Au over Ni	
Au90		500	min. 2,00µm (90pinch) Au over Ni	

Standard plating options highlighted in *italic*, other plating options are available on request.

### Recommended configuration of plated through holes for press-in termination

In addition to the hot-air-level (HAL), other PCB surfaces are getting more important. Due to their different properties - such as mechanical strength and coefficient of friction - we recommend the following configuration of PCB through holes.

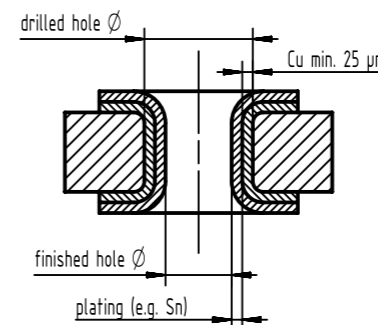

Tin plated PCB (HAL) acc. to EN 60352-5	Drilled hole Ø	1,15±0,025 mm
	Sn plated hole Ø	max. 15 µm
Chemical tin plated PCB	Drilled hole Ø	1,15±0,025 mm
	Sn plated hole Ø	min. 0,8µm
Gold /Nickel plated PCB	Drilled hole Ø	1,15±0,025 mm
	Ni plated hole Ø	3 - 7 µm
Silver plated PCB	Drilled hole Ø	1,15±0,025 mm
	Ag plated hole Ø	0,05 - 0,12 µm
Copper plated PCB (OSP)	Drilled hole Ø	1,15±0,025 mm
	plated hole Ø	1,00 - 1,10 mm

### Assembly instructions

It is highly recommended to use HARTING press-in tools to ensure a reliable press-in process. Please refer to the catalogue for tools, machines and further information about the press-in process.

### Soldering instructions

The connectors should be protected when being soldered in a dip, flow or film soldering baths. Otherwise, they might become contaminated as a result of soldering operations or deformed as a result of overheating.

(1) For prototypes and short runs protect the connectors with an industrial adhesive tape, e.g. Tesaband 4331 (www.tesa.de). Cover the underside of the connector moulding and the adjacent parts of the pcb as well as the open sides of the connector. This will prevent heat and gases of the soldering apparatus from damaging the connector. About 140 + 5 mm of the tape should suffice.

(2) For large series a jig is recommended. Its protective cover with a fast action mechanical locking device shields the connectors from gas and heat generated by the soldering apparatus. As an additional protection a foil can be used for covering the parts that should not be soldered.

### Cross section of solder terminations

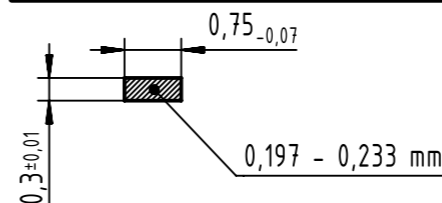

### Derating diagram acc. to IEC 60512-5 (Current carrying capacity)

The current carrying capacity is limited by maximum temperature of materials for inserts and contacts including terminals.

The current capacity curve is valid for continuous, non interrupted current loaded contacts of connectors when simultaneous power on all contacts is given, without exceeding the maximum temperature.

Control and test procedures according to DIN IEC 60512-5

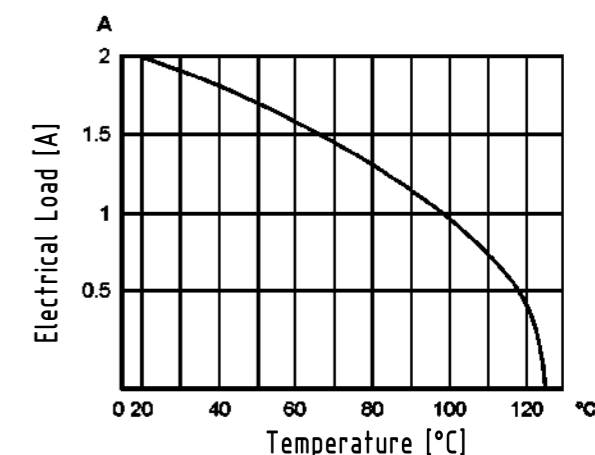

	All Dimensions in mm Original Size DIN A3	Scale 1:1	Free size tol.	Ref. Sub.
	All rights reserved Department EC PD - DE	Created by STORCK	Inspected by LEHNERT	Standardisation HOFFMANN
HARTING Electronics GmbH D-32339 Espelkamp	Title DIN Signale female connector		Date 2018-07-13	State Final Release
Type DS			Number 09032100001	Doc-Key / ECM-Nr. 100572187/UGD/001/C 500000137603
				Rev. C Page 1/1