

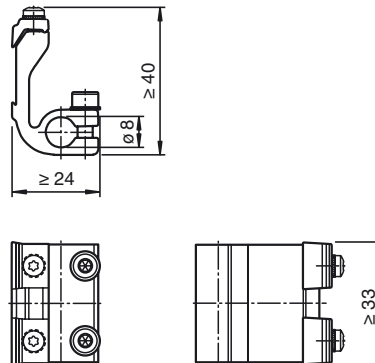

Dimensions



Model Number

OMH-SLCT-06

Swivel Bracket

Features

- Mounting bracket
- Sturdy construction
- Simple and fast mounting
- Pipe mounting
- Slewable without additional mounting aid

Technical data

Mechanical specifications

Material	Aluminum
Mass	approx. 28 g

General information

Scope of delivery	Mounting bracket ; Screw kit
-------------------	------------------------------

Suitable series

Safety Series	SLCT SLCS
---------------	--------------