



Filtration Hood and Spray Booth

Capture, contain and filter for a cleaner, healthier working environment within art, graphics, design technology areas, crafts and modelling.

Applications include filtration of:

Aerosol adhesives (glue booth for Spray Mount), aerosol lacquers and fixatives and airbrush sprays applied to artwork up to A1 size. A2 or A1 drawing boards can be placed into the hoods at an angle for efficient overspray capture.

The workstation hood also accommodates prototypes, models, ceramic parts, PCB's etc, placed onto the hood base to be sprayed, soldered, cleaned, glued, moulded, sanded etc.

A200H and A100H Air Filtration Cabinets



Demonstrating adequate control of the risks to the health of employees, students and the general public, from dusts, powders, mists, fumes and vapours is the fundamental requirement of the Control of Substances Hazardous to Health (COSHH) regulations 2002 and 2004.



GraphicAir Filtration Cabinets Model No's A200H and A100H

NOTE: These units are recirculatory; i.e. filtered air is exhausted back into the workplace.

Description

Steel construction finished in dove grey – fan/filter unit mounted onto hood enclosure - particulate filter – carbon impregnated fibre filter – axial fan(s), external rotor motor type brushless, UL, VDE and CSA approved (A100H has two fans) - sealed electrical wiring and switch, downstream of filters.

Operation

All WS filtration and extraction systems carry a lifetime warranty, are quiet in operation and can be assembled in seconds. Place onto a desk, bench or trolley and then simply plug in and switch on.

For artwork applications, standard A2 (A200H) or A1 (A100H) drawing boards can be placed within the hood enclosure. The boards fit at an angle for efficient overspray capture.

3D items, models, printed circuit boards etc. may be placed onto the hood base for spraying, cleaning, sanding etc.

'A' Dimensions = A200H (Weight 20kgs)

'B' Dimensions = A100H (Weight 35kgs)

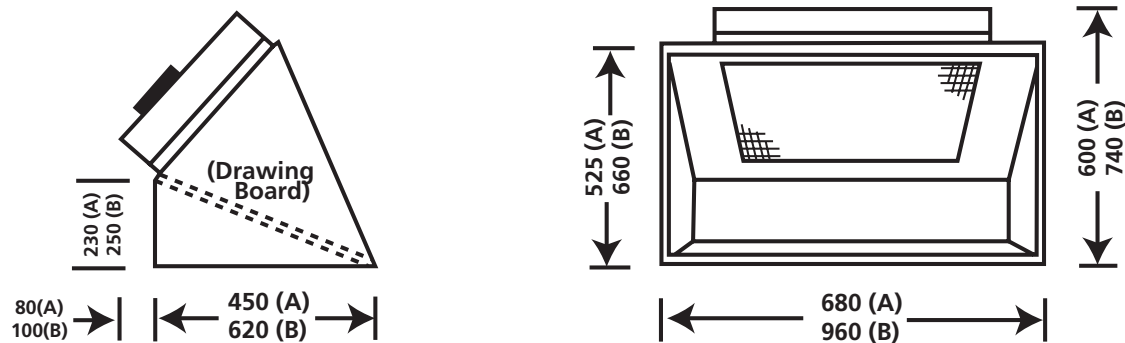

Filtration

The particulate (intake) filter is a three stage graduated fibre filter with a high 'dust' holding capacity for long life. Filtration to 5 micron particles. NB: Spray particulate sizes vary from 10 to 20 microns.

The carbon impregnated fibre filter (behind intake) assists in the reduction of solvent odours.

Through the process of filtration, adsorption and dilution, operator exposure to concentrations of potentially hazardous substances is vastly reduced.

Specification

Model Number	Fan Motor* Spec	Air Volume At Free Air	Ave. Air Velocity At Filter Face	Ave. Air Velocity At Hood Face	Noise Level LAeq dB(A)
A200H	230V 50Hz 40W	325 m3/hr	0.5 m/sec	0.25 m/sec	59
A100H	230V 50Hz 80W	650 m3/hr	0.5 m/sec	0.25 m/sec	61

* 110 Volts 50 or 60Hz available if required.

These units are designed predominantly for studio / classroom / workshop cleanliness and for immediate operator protection from concentrations of airborne contaminants. They are not recommended for continual usage, i.e. production applications, particularly in confined and/or badly ventilated areas.

See GraphicAir extraction cabinets A200H-D and A100H-D for total solvent odour and gas extraction, or TechFlo filtration cabinets for higher specification filtration

Please contact WS for advice on the choice of machine for any given situation.

WS Ltd, Unit 1 Levens Hall Park, Lund Lane, Harrogate, HG3 2BG, UK

T: +44 (0) 1423 522836 F: +44 (0) 1423 525656

E: enquiries@widespreadsolutions.co.uk Web: www.widespreadsolutions.co.uk