

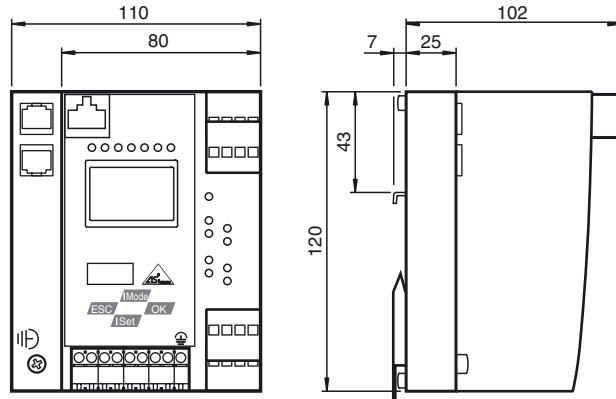

Dimensions

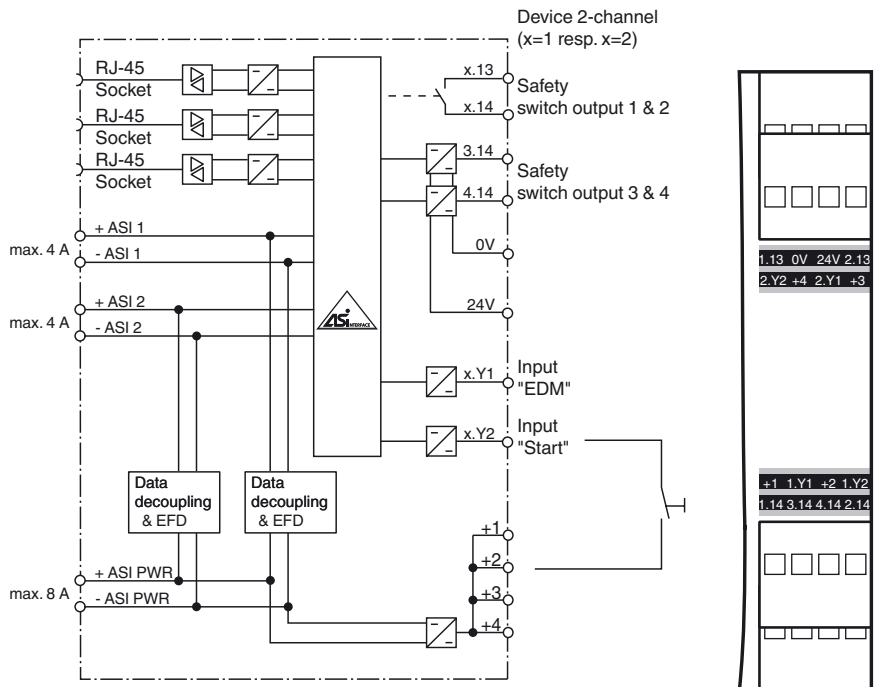

Electrical connection



Indicating / Operating means

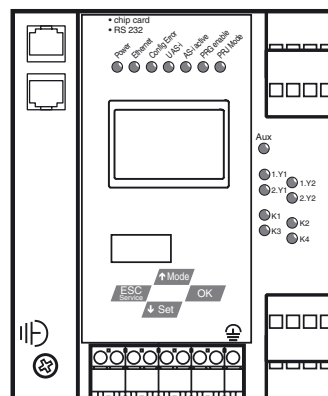

Model number

VBG-ENX-K30-DMD-S16-EV

EtherNet/IP + Modbus TCP Gateway with integrated safety monitor, double master for 2 AS-Interface networks, power supply input with data decoupling

Features

- Gateway and safety monitor in one housing
- Connection to Ethernet Modbus TCP/IP
- Integrated data decoupling
- Integrated webserver
- Certified up to SIL 3 according to IEC 61508 and EN 62061 and up to PL_e according to EN 13849
- Memory card for configuration data
- 2 AS-Interface networks
- 2 safe output relays and 2 safe electronic outputs
- Integrated switch allows line topology
- DLR technology supports ring topology

Release date: 2014-03-18 17:27 Date of issue: 2014-03-18 254539_eng.xml

Technical data**General specifications**

AS-Interface specification	V3.0
PLC-Functionality	activateable
Duplicate address detection	from AS-Interface slaves
Earth fault detection	EFD integrated
EMC monitoring	integrated
Diagnostics function	Extended function via display
Switch-on delay	< 10 s
Response delay	< 40 ms
UL File Number	E223772

Functional safety related parameters

Safety Integrity Level (SIL)	SIL 3
Performance level (PL)	PL e
MTTF _d	200 a
B _{10d}	2 E+7

Indicators/operating means

Display	Illuminated graphical LC display for addressing and error messages
LED ETHERNET	ethernet active; LED green
LED AS-i ACTIVE	AS-Interface operation normal; LED green
LED CONFIG ERR	configuration error; LED red
LED PRG ENABLE	autom. programming; LED green
LED POWER	voltage ON; LED green
LED PRJ MODE	projecting mode active; LED yellow
LED U AS-i	AS-Interface voltage; LED green
LED AUX	ext. auxiliary voltage U _{AUX} ; LED green
LED EDM/Start	External device monitoring circuit inputs closed, 4x yellow LEDs
LED output circuit	Output circuit closed; 4 x green LEDs
Button	4
Switch SET	Selection and setting of a slave address
OK button	Mode selection traditional-graphical/confirmation
Button MODE	Mode selection PRJ-operation/save configuration/cursor
ESC button	Mode selection traditional-graphical/cancel

Electrical specifications

Insulation voltage	U _i	≥ 500 V
Rated operating voltage	U _e	26.5 ... 31.6 V from AS-Interface; Output K3 and K4 24 V _{DC}
Rated operating current	I _e	≤ 300 mA from AS-Interface

Interface 1

Interface type	2 x RJ-45
Protocol	EtherNet/IP + MODBUS TCP/IP according to IEEE 802.3 supports device level ring protocol DLR
Transfer rate	10 MBit/s / 100 MBit/s, Automatic baud rate detection

Interface 2

Interface type	Ethernet: RJ-45 Diagnostic Interface
Transfer rate	10 MBit/s

Interface 3

Interface type	Chip card slot
----------------	----------------

Input

Number/Type	4 EDM/Start inputs: EDM: Inputs for the external device monitoring circuits Start: start inputs: Static switching current 4 mA at 24 V, dynamic 30 mA at 24 V (T=100 μs)
-------------	---

Output

Safety output	Output circuits 1 and 2: 2 potential-free contacts, max. contact load: 3 A _{DC-13} at 30 V _{DC} , 3 A _{AC-15} at 30 V _{AC} Output circuits 3 and 4: 2 PNP transistor outputs max. contact load: 0.5 A _{DC-13} at 30 V _{DC}
---------------	--

Connection

Ethernet	RJ-45
AS-Interface	spring terminals, removable

Ambient conditions

Ambient temperature	0 ... 55 °C (32 ... 131 °F)
Storage temperature	-25 ... 85 °C (-13 ... 185 °F)

Mechanical specifications

Degree of protection	IP20
Material	
Housing	Stainless steel
Mass	800 g
Construction type	Low profile housing, Stainless steel

Compliance with standards and directives**Function**

The VBG-ENX-K30-DMD-S16-EV is an Ethernet/IP+Modbus TCP gateway with an integrated safety monitor and a double master according to AS-Interface specification 3.0 with a degree of protection IP20.

The gateway has built-in decoupling coils. This allows two AS-Interface circuits to be operated by a single AS-Interface power supply.

The device is a gateway with full functionality combined with a safety monitor. The gateway connects an AS-Interface system to a higher-level Ethernet or Modbus protocol. It acts as a master for the AS-Interface segment and as a slave for Ethernet / Modbus. During cyclic data exchange, the digital data of an AS-Interface segment is transferred. Analog values as well as the complete command set of the new AS-Interface specification are transferred via Ethernet / Modbus using a command interface.

The gateway has four inputs and four outputs. The four inputs are used either for extended EDM device monitoring or as start inputs. Two sets of two outputs act as relay outputs and switch output circuits 1 and 2 and, as semiconductor outputs, output circuits 3 and 4. The K30 model is particularly suitable for installation in a control cabinet.

Configuration of the device can be performed using switches. Seven LED located on the front panel indicate the current status of the AS-Interface segment. One LED shows the power supply via AUX. A further eight LEDs indicate the status of the inputs and outputs.

With the graphical display, the commissioning of the AS-Interface circuits and testing of the connected peripherals can take place completely separately from the commissioning of the higher-level network and the programming. With the 4 switches, all functions can be controlled and visualized on the display.

The device has a card slot for a memory card for the storage of configuration data.

An integrated Switch and 2 RJ-45 sockets allow the design of a line topology without the use of an external Switch.

The device level ring protocol DLR increases the reliability of a ring topology at the device level, thus optimizing the machine running times.

An integrated webserver allows to administrate the device and The AS-interface network without additional hard and/or software via a browser interface.

Accessories**VAZ-SW-SIMON+**

Software for configuration of K30 Master Monitors/K31 and KE4 Safety Monitors

Directive conformity	
Machinery Directive 2006/42/EC	EN 61508-1:2010 EN ISO 13849-1:2008 EN 62061:2005
EMC Directive 2004/108/EC	EN 61000-6-2:2005, EN 61000-6-4:2007
Standard conformity	
Electromagnetic compatibility	EN 61000-6-2:2005, EN 61000-6-4:2007
AS-Interface	EN 50295:1999
Degree of protection	EN 60529:2000
Shock and impact resistance	EN 61131-2:2004
Standards	EN 61000-6-2:2005, EN 61000-6-4:2007 EN 61326-3-1:2008 IEC 61508:2010 and EN 62061:2005 (up to SIL3) EN 13849:2008 (PL e)

Notes

In an AS-Interface network only one device can be operated earth fault detection. If there are many devices in an AS-Interface network, this can lead to the earth fault monitoring response threshold becoming less sensitive.