

RoHS
Compliant

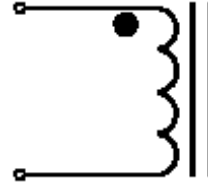

Schematic Diagram



- Note:**
1. Wire UEFN/U (155°C) Ø0.6mm
 2. 17TS (Reference) C.W

Configurations and Dimensions

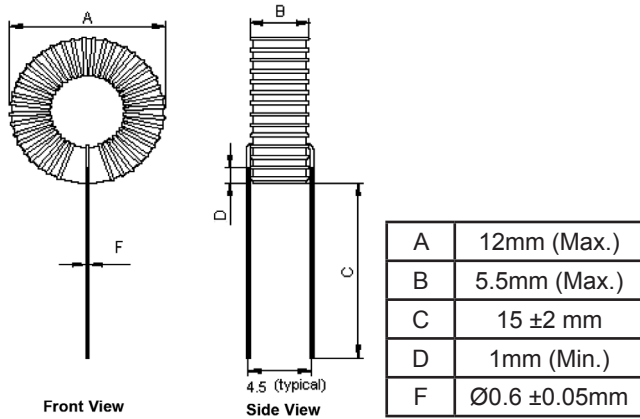

Test Data for Mechanical

Test Item	A mm	B mm	C mm	D mm	F mm
Specification	12 (Max.)	5.5 (Max.)	15 ±2	1 (Min.)	Ø0.6 ±0.5
1	11.11	4.68	15.34	1.98	0.59
2	11.12	4.72	14.9	1.97	0.6
3	11.15	4.68	15.2	1.96	0.59
4	11.13	4.69	15.24	1.95	0.6
5	11.14	4.71	15.31	1.99	
Average	11.13	4.7	15.2	1.97	0.6

Electrical Characteristics

Test Condition		
10kHz / 5V	L	8.2µH ±20%
T _A = 25°C	DCR	20mΩ (Max.)
10kHz / 5mA I _{rms} = 2A	ΔT	Temperature rise 40°C (Max.)

Operating temperature : -55°C to +130°C

Material List

No.	Item	Material Description
1	Core	T37-75-TAF200 (Red / White)
2	Wire	Ø0.6mm UEFN/U (155°C)
3	Solder (Lead-free)	Sn99.3% / Cu0.7%

Reliability Test

Test Item	Specifications	Test Method and Remarks
Operating temperature range	-55°C to +130°C	Including temperature rise due to self-generated heat.
Storage condition	Ambient temperature : 0°C to 40°C Humidity : Below 70% RH	To maintain the solderability of terminal electrodes, care must be taken to control temperature and humidity in the storage area.
Moisture sensitivity	Appearance : No abnormality No damage DCR change : Within ±5% Inductance change : Within ±5%	According to J-STD-020B level 3 Test condition : 60°C 60% RH Test duration : 40 hrs Recovery : 1 to 2 hours of recovery under the standard condition after the removal from the test chamber.
Solderability	All termination shall exhibit a continuous solder coating free from defects for a minimum of 95% of the surface area of any individual lead.	According to J-STD-002B Steam aging category : 97°C 98% RH Steam aging duration : 8 hrs Solder : Lead-free solder Solder temperature : 260 ±5°C Dip time : 5 +0 / -0.5s

Test Data for Electrical

Test Item	L μH	DCR mΩ	ΔT
Condition	10kHz / 5mA	T _A = 25°C	10kHz / 5mA I _{rms} = 2A
Specification	8.2 ±20%	20 (Max.)	Temperature rise 40°C (Max.)
1	8.16	15.09	OK
2	8.26	15.11	
3	8.38	15.09	
4	8.58	14.96	
5	8.42	15.56	
Average	8.36	15.16	OK

Part Number Table

Description	Part Number
Inductor, 8.2μH, 20%, 2 Pins	MCAP103722016A-8R2MU

Important Notice : This data sheet and its contents (the "Information") belong to the members of the AVNET group of companies (the "Group") or are licensed to it. No licence is granted for the use of it other than for information purposes in connection with the products to which it relates. No licence of any intellectual property rights is granted. The Information is subject to change without notice and replaces all data sheets previously supplied. The Information supplied is believed to be accurate but the Group assumes no responsibility for its accuracy or completeness, any error in or omission from it or for any use made of it. Users of this data sheet should check for themselves the Information and the suitability of the products for their purpose and not make any assumptions based on information included or omitted. Liability for loss or damage resulting from any reliance on the Information or use of it (including liability resulting from negligence or where the Group was aware of the possibility of such loss or damage arising) is excluded. This will not operate to limit or restrict the Group's liability for death or personal injury resulting from its negligence. Multicomp Pro is the registered trademark of Premier Farnell Limited 2019.