

TEE501

Digital Temperature Sensor

The TEE501 digital temperature sensing element meets highest requirements in terms of accuracy and reliability. Its diverse applications range from industrial and building automation to medical devices or white goods. A footprint of only 2.5 x 2.5 mm and integrated pull-up resistors facilitate the design-in of the TEE501.

The DFN 8-pin package allows up to 8 devices on one I2C interface. Furthermore, the TEE501 convinces with an operating range from -40 to 135°C and an accuracy of up to ± 0.2 °C, which makes it an ideal solution for demanding measuring tasks.



Key Features

- Accuracy up to ± 0.2 °C
- Supply voltage 2.35 - 3.60 V
- 8-pin DFN package
- I²C interface with pin-selectable addresses
- Integrated I²C pull-up resistors
- I²C glitch suppression
- I²C interface with direct 16 bit integer output
- Excellent repeatability

Typical Applications

- Building automation
- Consumer electronics
- Home appliances
- Industrial automation
- Medical devices
- Smart home
- Wearable devices
- White goods

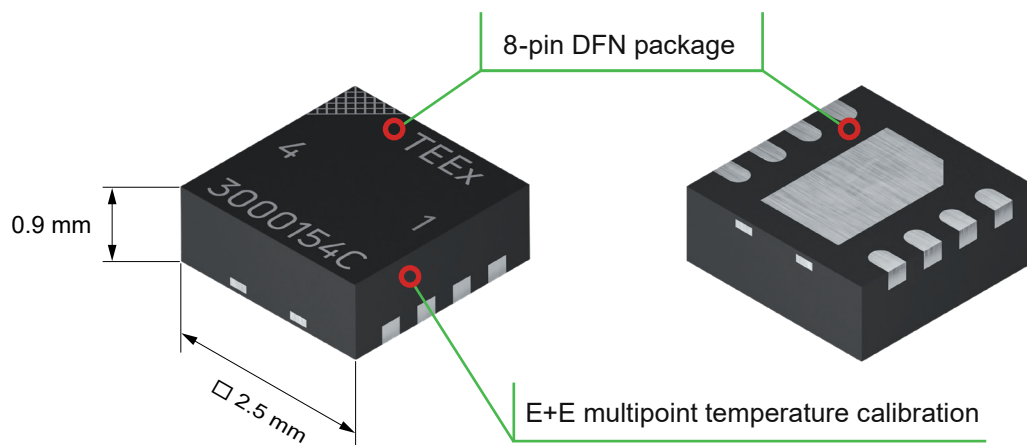

CONTENTS

Introduction to the E+E Digital Temperature Sensor	1
1 Pin Configuration	5
2 Typical Application.....	5
3 Specifications	6
3.1 Temperature Sensor.....	6
3.2 Recommended Operating Conditions	6
4 Electrical Characteristics	7
4.1 Absolute Maximum Ratings.....	7
4.2 Electrical Specification	7
5 Interface	9
5.1 Supply Pins (V _{DD} , GND).....	9
5.2 I ² C Communication	10
5.3 I ² C Address Pins	10
5.4 I ² C Pin.....	11
6 Sensor Communication	11
6.1 Command Overview.....	11
6.2 Measured Data Format	11
6.3 Measurement Modes.....	11
6.4 Single Shot Measurement (0x2C1B, 0x241D)	12
6.5 Periodic Measurement (0x201E).....	13
6.6 Fetch Periodic T Measurement Results (0xE000).....	14
6.7 Break Command (0x3093)	14
6.8 Reset Commands (0x30A2, 0x06)	14
6.9 Status Register (0xF32D, 0xF352, 0x3041).....	15
6.10 Read Identification (0x7029)	17
6.11 Change Sensor Settings (0x72A7).....	18
6.12 CRC Calculation.....	19
6.13 Package / Dimensions.....	19
6.14 Tape and Reel Packaging	20
6.15 Traceability	20
6.16 Ordering Information	21
6.17 Recommended Layout	21
7 Quality	21
8 Additional Documentation.....	21
9 Revision History.....	21

LIST OF FIGURES

Figure 1: DFN8 pin configuration.....	5
Figure 2: Typical application schematic.....	5
Figure 3: Temperature sensor accuracy	6
Figure 4: Measurement duration	9
Figure 5: Sensor behaviour at power-up	10
Figure 6: Single shot measurement.....	11
Figure 7: Periodic measurement	12
Figure 8: Start single-shot measurement readout	12
Figure 9: Clock stretching during measurement.....	12
Figure 10: Poll for measuring values until ACK.....	13
Figure 11: Measured value readout.....	13
Figure 12: Periodic measurement commands.....	13
Figure 13: Fetch command.....	14
Figure 14: Break command	14
Figure 15: Soft reset.....	15
Figure 16: Reset through general call	15
Figure 17: Read out status register	15
Figure 18: Clear status register 1	16
Figure 19: Read identification.....	17
Figure 20: Memory access	18
Figure 21: CRC8 properties.....	19
Figure 22: Package layout.....	19
Figure 23: Tape layout	20
Figure 24: Orientation on the tape.....	20
Figure 25: TEEEx laser marking	20
Figure 26: Recommended land pattern and stencil aperture	21

LIST OF TABLES

Table 1: List of TEEEx specific acronyms	4
Table 2: TEE501 pin assignment.....	5
Table 3: Temperature sensor parameters.....	6
Table 4: TEE501 absolute maximum ratings	7
Table 5: General operation	7
Table 6: I ² C communication pins SCL & SDA.....	8
Table 7: I/O pins.....	8
Table 8: General timing.....	8
Table 9: Measurement resolution	9
Table 10: TEE501 commands	11
Table 11: Status Register 1.....	16
Table 12: Status Register 2	17
Table 13: Sensor settings registers	18
Table 14: Package dimensions.....	19
Table 15: Applicable documentation.....	21
Table 16: Revision history.....	21

ACRONYM	MEANING
A	Ambient
B	Bus
CDM	Charged Device Model
ESD	Electrostatic Discharge
HBM	Human Body Model
HI	Measurement Invalid
MEAS	Measurement, Measuring
PORI	Power On Reset, Idle Mode
PORP	Power On Reset, Periodic Mode
POR	Power On Reset
PU	Pull-up
PUPE	Pull-up external
PUPI	Pull-up internal
PWRU	Power Up
T	Temperature

Table 1: List of TEEEx specific acronyms

1 Pin Configuration

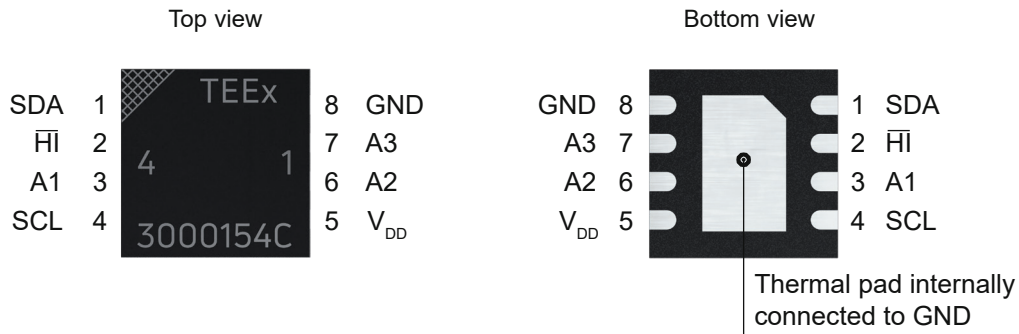

Figure 1: DFN8 pin configuration

PIN #	NAME	PIN TYPE	DESCRIPTION
1	SDA	I/O with pull-up	Serial data line for I ² C communication
2	HI	Output open drain	Indicates invalid measurement
3	A1	Input high-Z	I ² C device address pin, bit 1 of the 7 bit address; do not leave floating
4	SCL	I/O with pull-up	Serial clock line for I ² C communication
5	V _{DD}	Power	Positive supply pin
6	A2	Input high-Z	I ² C device address pin, bit 2 of the 7 bit address; do not leave floating
7	A3	Input high-Z	I ² C device address pin, bit 3 of the 7 bit address; do not leave floating
8	GND	Power	Ground (internally connected to thermal pad)

Table 2: TEE501 pin assignment

2 Typical Application

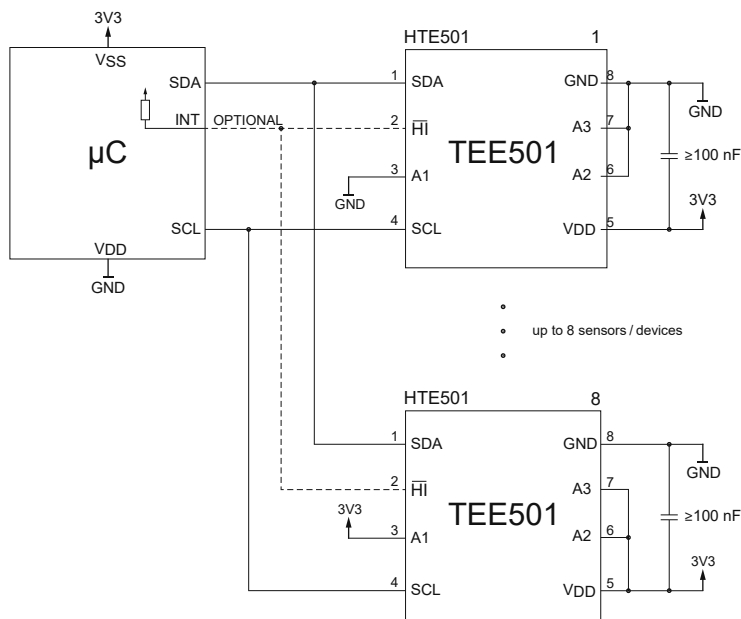

Figure 2: Typical application schematic

3 Specifications

3.1 Temperature Sensor

PARAMETER	CONDITION	MIN	TYP	MAX	UNIT
Operating Range		-40		135	°C
Accuracy			0.2	See Figure 3	°C
Resolution ¹⁾	13 bit		0.01		°C
Repeatability ²⁾	13 bit		0.03		°C
Response time ³⁾	τ_{63}	2			s
Long Term Drift			<0.03		°C/yr

Table 3: Temperature sensor parameters

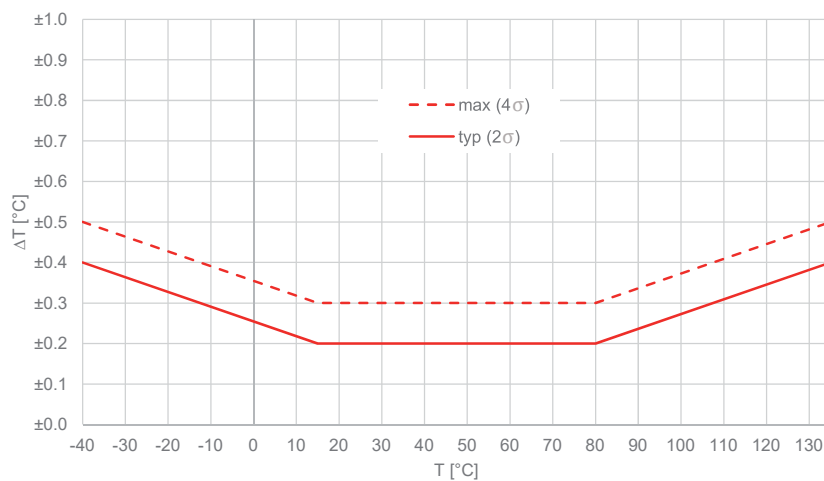

Figure 3: Temperature sensor accuracy

3.2 Recommended Operating Conditions

The TEE501 sensor can be used in the temperature range -40°C...+135°C.

- 1) Default resolution is 13 bit temperature. Resolution is changeable with register value.
- 2) The stated "Noise / Repeatability" is 3 times the standard deviation (3σ) of multiple consecutive measurement values at constant environmental conditions.
- 3) Time for achieving 63 % of a step function, valid at 25°C and 1m/s airflow.
 The actual response time in application strongly depends on the surrounding of the sensor in the final application (heat conductivity of sensor substrate, dead volume, ...).

4 Electrical Characteristics

4.1 Absolute Maximum Ratings

The absolute maximum ratings as given in Table 4 are stress ratings only and give additional information. Functional operation of the device at these conditions is not implied. Exposure to absolute maximum rating conditions for extended periods may affect the device reliability (e.g. hot carrier degradation, oxide breakdown).

PARAMETER	SYMBOL	MIN	MAX	UNIT
Power Supply	V_{DD}	-0.3	3.6	V
Digital I/O pins	V_{LOGIC}	-0.3	5.0	V
Input Current on any pin	I_{IN}	-50	50	mA
Storage Temperature	T_{STG}	-55	150	°C
ESD HBM ¹⁾	ESD_{HBM}	-	4	kV
ESD CDM ²⁾	ESD_{CDM}	-	750	V

1) Human Body Model according to AEC-Q100-002

2) Charged Device Model according to AEC-Q100-011

Table 4: TEE501 absolute maximum ratings

4.2 Electrical Specification

Typical values correspond to $V_{DD} = 3.3$ V and $T_A = 25$ °C.

Min. and max. values are valid in the full temperature range -40 °C ... 135 °C and at declared V_{DD} levels, unless otherwise noted.

PARAMETER	SYMBOL	CONDITION / COMMENT	MIN	TYP	MAX	UNIT
Supply Voltage	V_{DD}		2.35	3.3	3.6	V
POR voltage periodic mode	V_{PORP}	Static power supply	2.10	2.20	2.35	V
POR voltage idle mode	V_{PORI}	Static power supply		1.8		V
Supply current	I_{DD}	Single mode (idle) ¹⁾		6		μA
		Periodic mode ¹⁾		80		μA
		Measuring T, Calculation		900		μA
Thermal resistance	R_{TH}	Dependent on PCB layout and enviromental conditions		150		K/W

1) Without I²C communication and when not measuring

Table 5: General operation

PARAMETER	SYMBOL	CONDITION / COMMENT	MIN	TYP	MAX	UNIT
Input voltage	V _{IL}	Low level			0.3*V _{DD}	V
	V _{IH}	High level	0.7*V _{DD}		V _{DD}	V
Output voltage	V _{OL}	Current into pin: I _{OL} = 4.0 mA	0	0.25	0.40	V
	V _{OH}	High level → open drain				
Internal pull-up resistor	R _{PUP1}	V _{DD} =3.60 V & pin voltage = 0.7*V _{DD}		25		kΩ
		V _{DD} =3.30 V & pin voltage = 0.7*V _{DD}		27		kΩ
		V _{DD} =3.00 V & pin voltage = 0.7*V _{DD}		30		kΩ
		V _{DD} =2.35 V & pin voltage = 0.7*V _{DD}		34		kΩ
External pull-up resistor	R _{PUPE}	At I ² C lines, pull-up current ≤4.0 mA @ 3.3 V	0.725	4.7		kΩ
Capacitive bus load	C _B	Standard			400	pF
		Fast mode			400	pF
		Fast mode plus			177	pF

1) Characterized but not tested.

Table 6: I²C communication pins SCL & SDA

PARAMETER	SYMBOL	CONDITION / COMMENT	MIN	TYP	MAX	UNIT
Input voltage	V _{IL}	Low level			0.3*V _{DD}	V
	V _{IH}	High level, 5V tolerant input	0.7*V _{DD}	V _{DD}	5.0	V
Input leakage current	I _{VDD}	Voltage @pin = 0...V _{DD}	-10	0	+10	μA
	I _{ISV}	Voltage @pin = V _{DD} ...5 V		TBD		μA
Output resistance	R _{OH}	Voltage @pin = V _{DD} -0.4 V		116		Ω
	R _{OL}	Voltage @pin = 0.4 V		100		Ω

Table 7: I/O pins

PARAMETER	SYMBOL	CONDITION / COMMENT	TYP	UNIT
Power-up time	t _{PWRU}	After V _{DD} > V _{PORP} , exclude measurement at power-up	1.1	ms
Reset time	t _{RESET}	Any reset except power-up	0.9	ms
T-Measurement	t _T	8 bit resolution	0.4	ms
		9 bit resolution	0.7	ms
		10 bit resolution	1.3	ms
		11 bit resolution	2.4	ms
		12 bit resolution	4.6	ms
		13 bit resolution	9.0	ms
14 bit resolution	17.9	ms		
Measurement calculation	t _{CALC}	After every measurement	1.2	ms
SCL SDA input filter	t _{spike}	Short voltage spikes are ignored	25	ns

Table 8: General timing

Subsequently, the typical time from V_{DD} > V_{PORP} to measurement ready in the standard configuration is:
t_{RDY} = t_{PWRU} + t_{MEAS} = t_{PWRU} + t_T + t_{CALC} = 11.3 ms

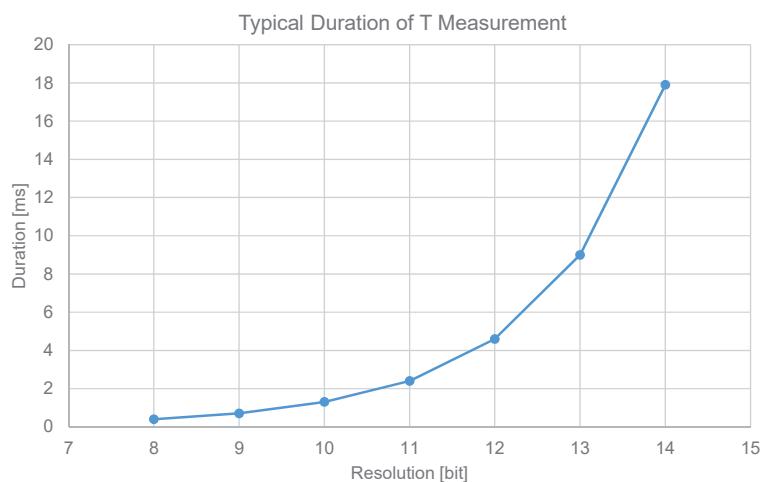

Figure 4: Measurement duration

TEMPERATURE	
bit	Resolution [°C]
14	0.01
13	0.01
12	0.02
11	0.06
10	0.11
9	0.21
8	0.42

Table 9: Measurement resolution

5 Interface

5.1 Supply Pins (V_{DD} , GND)

The supply pins must be equipped with a bypass ceramic capacitor of at least 100 nF.

Sensor Power-up

As soon as V_{DD} exceeds the POR voltage V_{PORP} , the device gets initialized. After t_{PWRU} , the initialization procedure is completed and a single shot measurement is carried out automatically. After the measurement time ($t_T + t_{CALC}$) the measured values are available at the I²C interface. The \overline{FI} pin indicates the availability of a valid temperature measurement after power-up (see chapter 1 Pin Configuration).

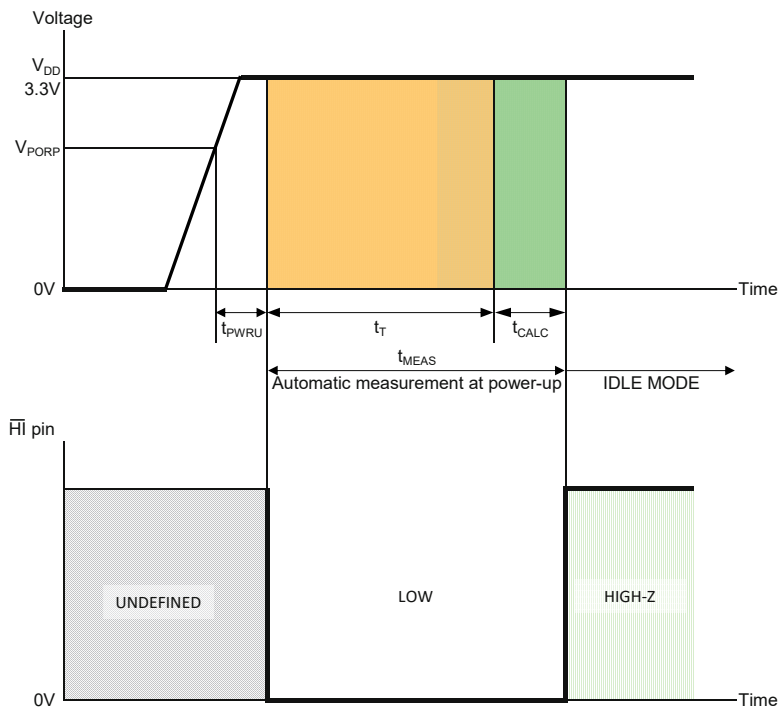

Figure 5: Sensor behaviour at power-up

5.2 I²C Communication

The I²C communication is based on the NXP UM10204 I²C bus specification and user manual¹⁾. The TEE501 supports the modes “standard” (100 kHz), “fast mode” (400 kHz) and “fast mode plus” (1 000 kHz).

The sensor works as SLAVE and needs to be queried by a MASTER.

Please consider self-heating due to a low R_{PU} when the sensor has to sink the pull-up current. In this case, the residual voltage on the SCL or SDA pin briefly generates a power loss in the sensor.

Example: 4mA * 0.4V = 1.6mW

5.3 I²C Address Pins

The sensor’s I²C base address is 0x48 (without R/W bit). Pins A1...A3 define the I²C base address.

				PIN 7	PIN 6	PIN 3					
				A3	A2	A1	R/W	SLAVE Address (unshifted)	SLAVE Address (with W)	SLAVE Address (with R)	
bit #	7	6	5	4	3	2	1	0			
	1	0	0	1	0	0	0	0/1	0x48	0x90	0x91
	1	0	0	1	0	0	1	0/1	0x49	0x92	0x93
	1	0	0	1	0	1	0	0/1	0x4A	0x94	0x95
	1	0	0	1	0	1	1	0/1	0x4B	0x96	0x97
	1	0	0	1	1	0	0	0/1	0x4C	0x98	0x99
	1	0	0	1	1	0	1	0/1	0x4D	0x9A	0x9B
	1	0	0	1	1	1	0	0/1	0x4E	0x9C	0x9D
	1	0	0	1	1	1	1	0/1	0x4F	0x9E	0x9F

1) Revision 6, 4 April 2014, download from <https://www.nxp.com/docs/en/user-guide/UM10204.pdf>.

5.4 $\overline{\text{HI}}$ Pin

The $\overline{\text{HI}}$ pin indicates that recent T measurement was invalid:

- a. Recent measurement was:
 - i. valid \rightarrow pin = high-Z
 - ii. invalid \rightarrow pin = LOW

The status of each measurement (valid/invalid) can be read out from the status register 2.
- b. During power up until the start-up measurement and calculation is finished (please refer to Figure 5 in chapter 5.1.)

6 Sensor Communication

6.1 Command Overview

COMMAND	DESCRIPTION
0x2C1B	Measurement, single shot, I ² C clock stretching enabled; Use current resolution
0x241D	Measurement, single shot, I ² C clock stretching disabled; Use current resolution
0x201E	Measurement, periodic; Use current resolution and interval
0xE000	Fetch periodic measurement data
0x30A2	Soft Reset
0x3093	Break (end periodic measurement)
0x3041	Clear Status Register 1
0xF32D	Readout of Status Register 1
0xF352	Readout of Status Register 2
0x7029	Read Identification
0x72A7	Read / Write Sensor Settings (RAM)
0x06	I ² C Reset at general call address 0x0

Table 10: TEE501 commands

6.2 Measured Data Format

$$\text{Temperature [}^{\circ}\text{C]} = (\text{Temperature MSB} \times 256 + \text{Temperature LSB}) / 100$$

6.3 Measurement Modes

There are two different operation modes to communicate with the sensor:

1. Single Shot Measurement

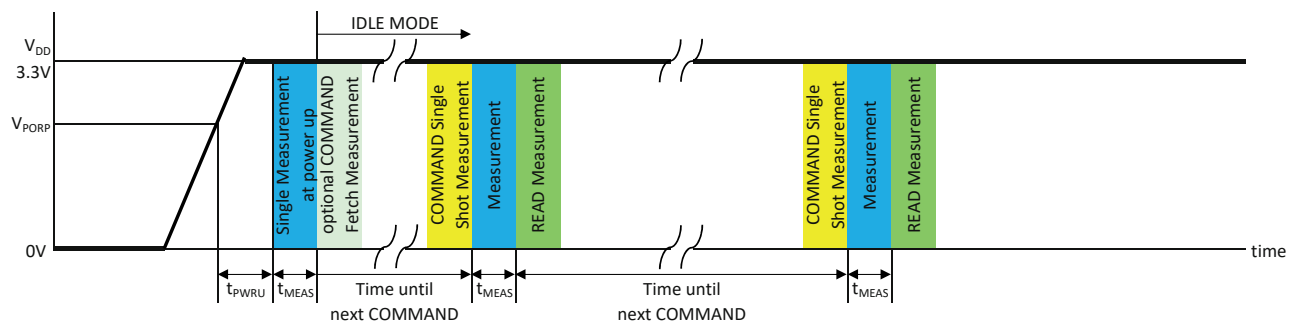

Figure 6: Single shot measurement

2. Periodic Measurement

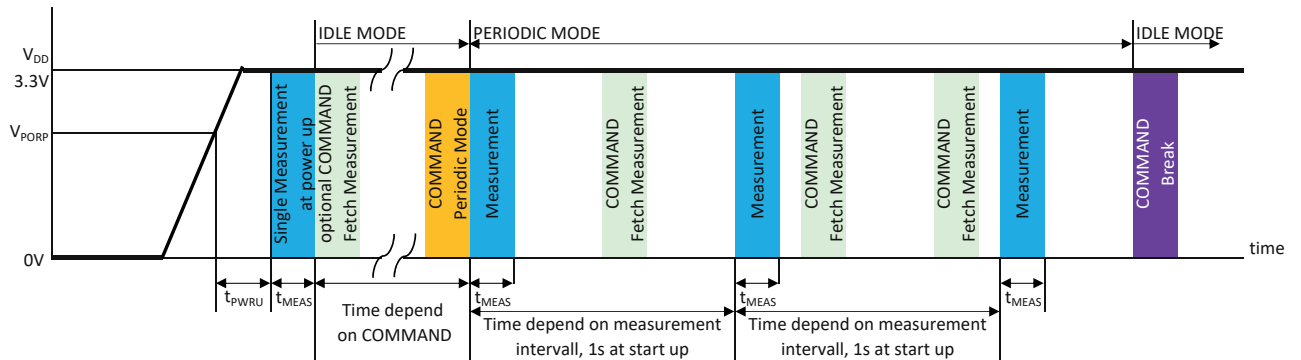

Figure 7: Periodic measurement

6.4 Single Shot Measurement (0x2C1B, 0x241D)

The command initiates a single measurement, the measured data is available for query after t_{MEAS} .
 I²C clock stretching enabled: waiting for the end of the measurement during command execution.

Condition	CMD Hex Code	
	MSB	LSB
I ² C clock stretching Enabled	0x2C	0x1B
I ² C clock stretching Disabled	0x24	0x1D

A single-shot measurement is started after the command has been received successfully. The readout of the calculated T value is started by sending the I²C address again in read mode:

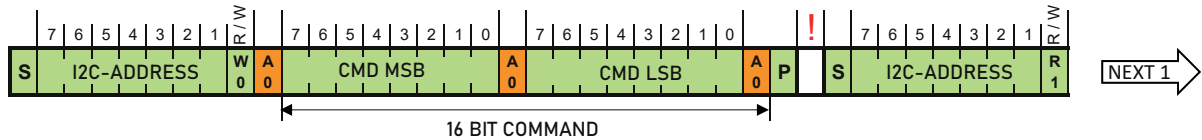

Figure 8: Start single-shot measurement readout

In case a command with clock stretching enabled has been issued, the slave holds SCL low until the calculation has been finished:

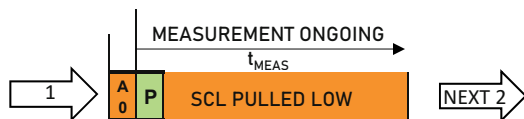

Figure 9: Clock stretching during measurement

Data Bit From Master to Slave
 Data Bit From Slave to Master
! = Note the deviation!
S = Start condition **R** = Read Bit
P = Stop condition **W** = Write Bit
A = Acknowledge (SDA low)
N = Not Acknowledge (SDA high)

In case a command without clock stretching has been issued, the slave does not acknowledge (NACK) a read header as long as the calculation has not been finished:

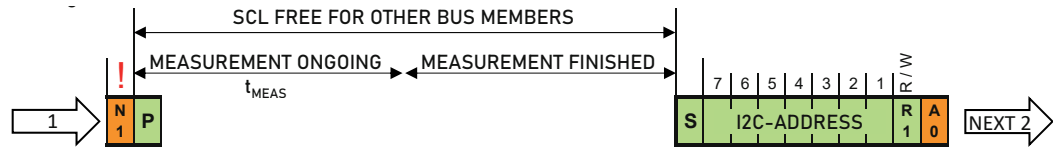

Figure 10: Poll for measuring values until ACK

After the calculation is finished, the slave responds to a read header with a pair of data words, each of them is followed by an 8 bit checksum (CRC8). The first data word contains the temperature value while the second word contains the relative humidity value. The master has to acknowledge each single data byte by an acknowledge (ACK), otherwise the slave will stop sending any further data and wait for a stop condition (P):

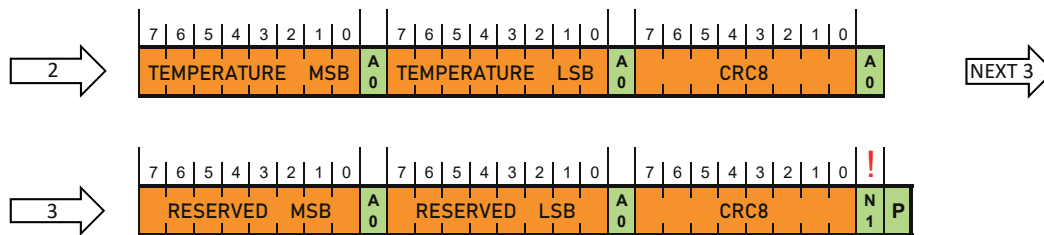

Figure 11: Measured value readout

6.5 Periodic Measurement (0x201E)

Once issued, measurements and calculations are started automatically with a given measuring interval and resolution.

The standard measurement interval is 1 s and the T resolution is 13 bit. If necessary the measurement frequency and the measurement resolution can be changed (see chapter 6.11).

This mode does not support clock stretching.

Command	CMD Hex Code
Periodic measurement	201E

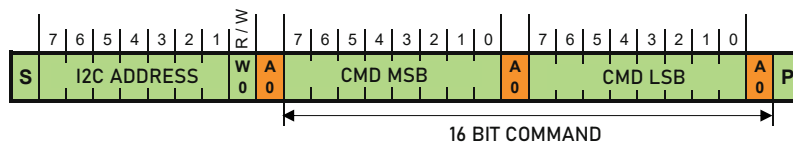

Figure 12: Periodic measurement commands

A periodic measurement command with a different measurement interval / resolution can be issued at any time, but the calculated value will be updated according the new settings earliest after a measurement with the new settings has been performed. Please refer to Chapter 6.11.

6.6 Fetch Periodic T Measurement Results (0xE000)

Readout of calculation results in periodic measurement mode can be performed using the fetch command. This is similar to the readout of measurement results in single-shot mode, except that clock stretching is always disabled. The slave will answer with NACK if no measurement results are available.

Command	CMD Hex Code
Fetch data	0xE000

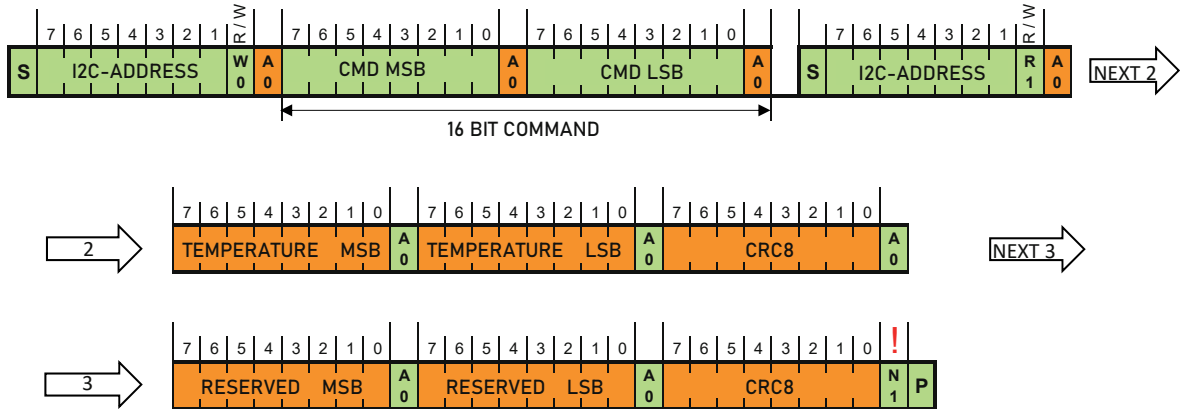

Figure 13: Fetch command

This command is also suitable to retrieve the measured data generated by the power-up procedure.

6.7 Break Command (0x3093)

The periodic measurement mode can be stopped using the break command. After finishing an ongoing measurement, the sensor will enter the idle mode. An ongoing measurement can delay the transition into the idle mode.

Command	CMD Hex Code
Break	0x3093

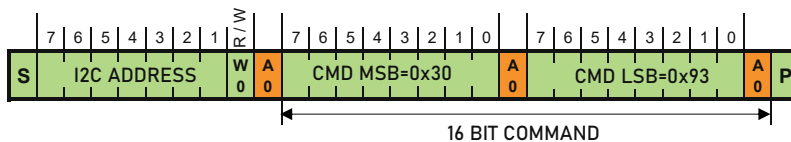

Figure 14: Break command

A single measurement (command) or a reset (command or power-up) both stop the periodic measurement, too.

6.8 Reset Commands (0x30A2, 0x06)

The slave supports multiple commands to reset the device. Once a reset command is received, the device is completely reset, like a reset during power-up. During the reset time, the device will not respond to any request on the I²C interface.

In order to execute the reset on a specific device, the command “Soft Reset” can be used. This forces the system to execute the startup procedure without the need to remove the power supply. The protection will be re-established with the “Soft Reset”.

Command	CMD Hex Code
Soft reset	0x30A2

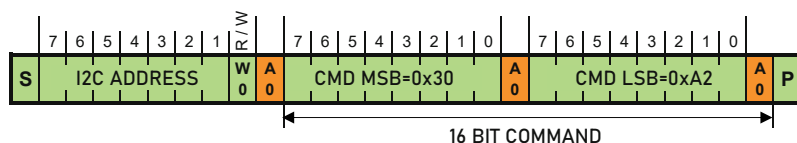

Figure 15: Soft reset

In order to reset all devices on the bus, the master can use the “General call” mode. This generates a reset (system startup) in all devices on the bus which support this function. The effect is the same as for the “Soft Reset” command.

Command	Hex Code
Address byte	0x00
Second byte	0x06

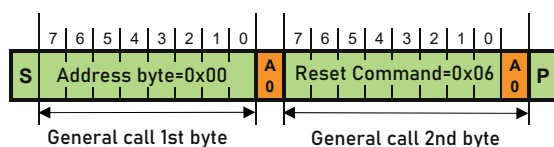

Figure 16: Reset through general call

In order to reset the I²C interface only, keep SDA high while toggling SCL nine times or more. This must be followed by a start condition preceding the next command. This sequence does not affect any configuration, status register or system status.

6.9 Status Register (0xF32D, 0xF352, 0x3041)

The sensor implements two 16 bit status registers. Their contents can be read using the following commands:

Command	CMD Hex Code	
	MSB	LSB
Read out Status Register 1	0xF3	0x2D
Read out Status Register 2		0x52

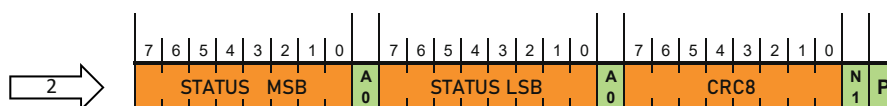
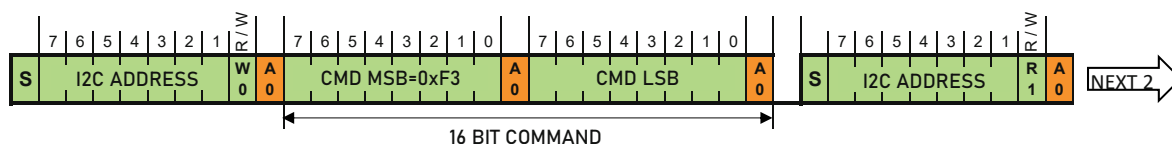

Figure 17: Read out status register

Upon receipt of the following clear command, bits 15, 4 and 3 are cleared in status register 1. All other bits remain unaffected:

Command	CMD Hex Code
Clear Status Register	0x3041

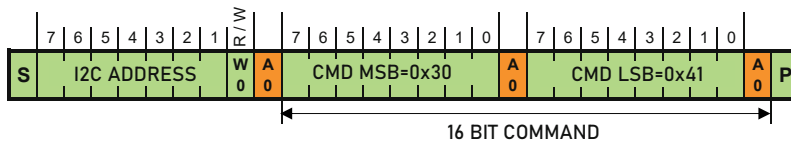

Figure 18: Clear status register 1

The Status Register 2 is read only!

BIT	NAME	DESCRIPTION
15	OVERALL_ERROR	0: none of bits [11:0] set 1: at least one of bits [11:0] set This bit is cleared upon the Clear Status Register 1 command
14	Reserved	-
13	Reserved	-
12	Reserved	-
11	Reserved	-
10	Reserved	-
9	Reserved	-
8	Reserved	-
7	Reserved	-
6	Reserved	-
5	Reserved	-
4	System Reset	0: no reset since status 1 clear 1: POR or I ² C reset This bit is cleared upon the Clear Status Register 1 command
3	POR	0: no POR since status 1 clear 1: POR occurred This bit is cleared upon the Clear Status Register 1 command
2	Reserved	-
1	Reserved	-
0	CRC	1: checksum of the latest write transfer failed

Table 11: Status Register 1

BIT	NAME	DESCRIPTION
15	NEW_MEAS	New T measurement since last readout available
14	NEW_T_MEAS	New T value since last readout available Cleared upon start of T readout
13	Reserved	-
12	Reserved	-
11	Reserved	-
10	PERIODIC_MODE	Status of cyclic measurement 0: only measurements on demand 1: periodic mode active
9	Reserved	-
8	Reserved	-
7	Reserved	-
6	Reserved	-
5	Reserved	-
4	Reserved	-
3	Reserved	-
2	Reserved	-
1	Reserved	-
0	T_VALID	0: T measurement faulty 1: T measurement OK

Table 12: Status Register 2

6.10 Read Identification (0x7029)

Each sensor device has a specific 8-byte identification.

This Identification allows a factory backtracking of each device.

As soon as the following command is issued, the I²C slave sends all 8 bytes consecutively, followed by a CRC8 checksum (see chapter 6.12).

Command	CMD Hex Code
Read Identification	0x7029

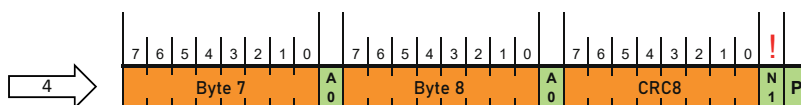
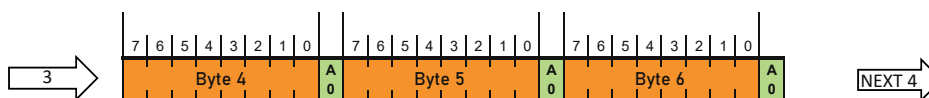
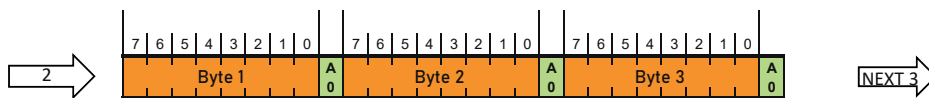
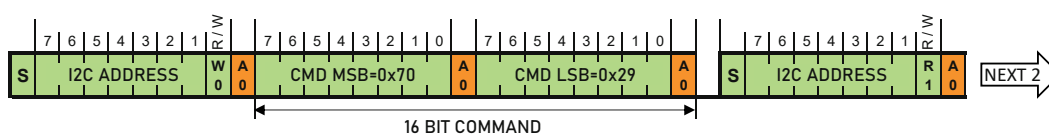

Figure 19: Read identification

Example:
"1C4606026156553C" (Hexadecimal)

6.11 Change Sensor Settings (0x72A7)

This command allows to change the sensor's settings. They stay in place until any reset. Sensor settings can only be changed in idle mode.

Command	CMD Hex Code
Change Sensor Settings	0x72A7

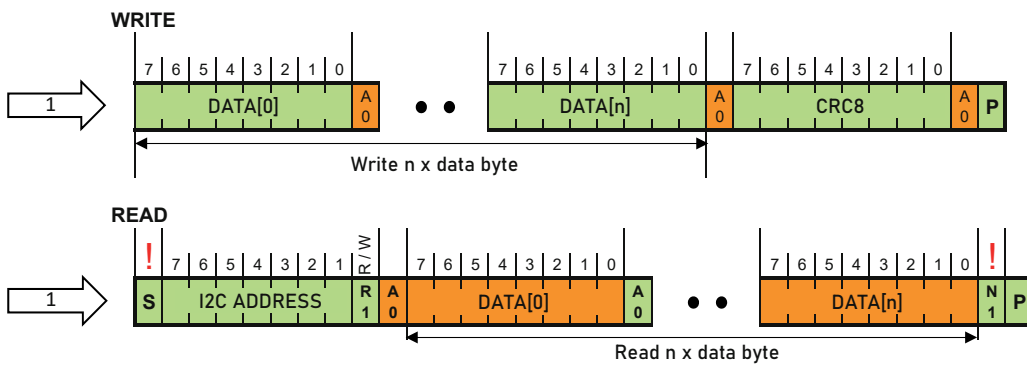
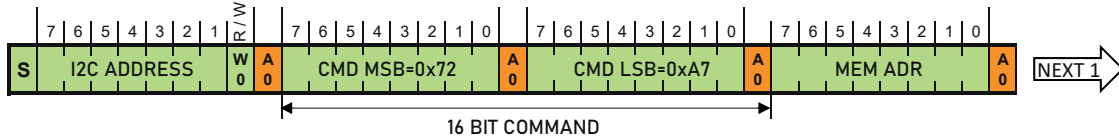

Figure 20: Memory access

ADDRESS	FUNCTION	DEFAULT VALUE	DESCRIPTION			
			BIT	NAME	R/W	DESCRIPTION
0x0F	Measurement resolution	0x2D (0010 1101) T = 13 bit	7:0	T_RES	R/W	0x00: 8 bit 0x01: 9 bit 0x02: 10 bit 0x03: 11 bit 0x04: 12 bit 0x05: 13 bit 0x06, 0x07: 14 bit Others: reserved
			15:0	RM_CYCLE	R/W	Measurement cycle in run- mode. Unit of an LSB is 1/20 s (50 ms), RM_CYCLE ranges from 0 (start immediately after calculation is done) to 0xffff * 0.05 s = 54 m 36.75 s

Table 13: Sensor settings registers



Please note:

A short measurement interval can influence the power consumption and therefore the self-heating of the sensor.

6.12 CRC Calculation

Response data words/memory write data are protected by a CRC8 checksum:

Property	Value
Name	CRC8
Width	8 bit
Polynomial	0x31 (x8 + x5 + x4 + x1)
XOR input	0xFF
Reflect input	False
Reflect output	False
XOR output	0x00

Figure 21: CRC8 properties

6.13 Package / Dimensions

The TEE501 sensor is provided as a DFN (= Dual Flat No Leads) package.

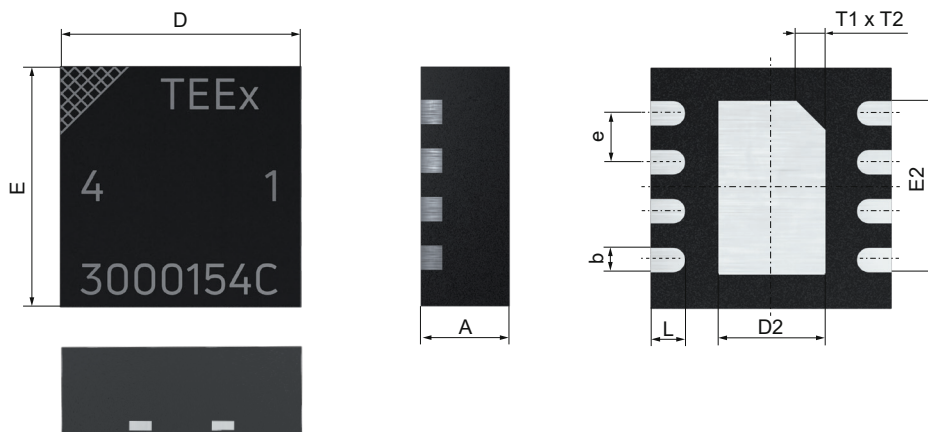

Figure 22: Package layout

PARAMETER	SYMBOL	MIN.	NOM.	MAX.	UNIT	COMMENT
Package width	D	2.40	2.50	2.60	mm	
Package length	E	2.40	2.50	2.60	mm	
Package height	A	0.80	0.90	1.00	mm	
Leadframe height	A3		0.20		mm	Not shown in the drawing
Pad pitch	e		0.50		mm	
Pad width	b	0.20	0.25	0.30	mm	
Pad length	L	0.30	0.35	0.40	mm	
Thermal pad length	D2	1.00	1.10	1.20	mm	
Thermal pad width	E2	1.70	1.80	1.90	mm	
Thermal pad marking	T1xT2		0.30 x 0.30		mm	Indicates pin 1

Table 14: Package dimensions

6.14 Tape and Reel Packaging

The TEE501 has a Moisture Sensitivity Level (MSL) of 1, according to IPC/JEDEC J-STD-020E. It is recommended to further process the TEE501 sensors within 1 year after date of delivery.

Dimensions T&R in mm:

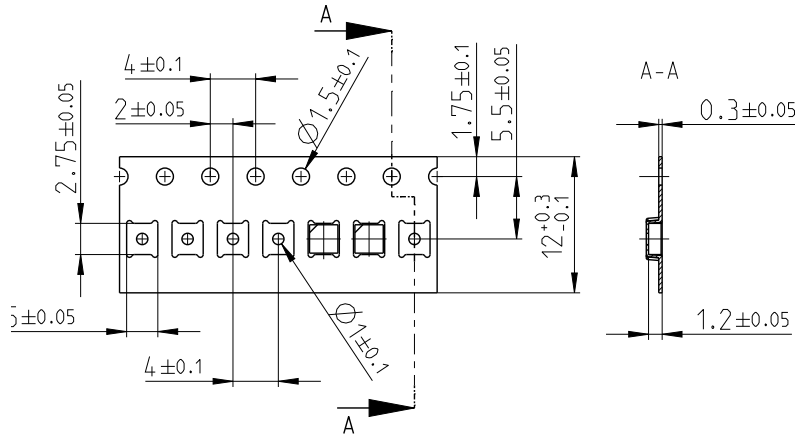

Figure 23: Tape layout

Orientation on the tape:

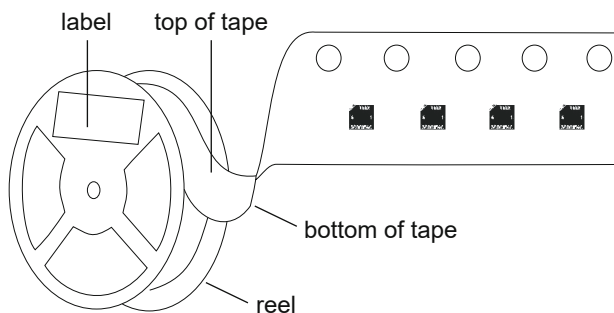

Figure 24: Orientation on the tape

6.15 Traceability

There are two possibilities for identification / traceability:

1. Read identification command (0x7029):
 serial number of each individual sensor (see description of command 0x7029)
2. Laser marking:



A triangular mark at the top left indicates pin 1.

The upper line represents the designation of the component and consists of up to 6 characters. The "x" is a placeholder for the exact type, e.g. 501.

The remaining characters are a tracking code and are used by the manufacturer for identification.

Figure 25: TEE_x laser marking

6.16 Ordering Information

TYPE	TAPE AND REEL PACKAGING		
TEE501	TEE501	2500 sensors	TR2,5
		Cut-tape	TRCT

Ordering example:

TEE501-TR2,5

Type: TEE501

Packaging: 2500 sensors

6.17 Recommended Layout

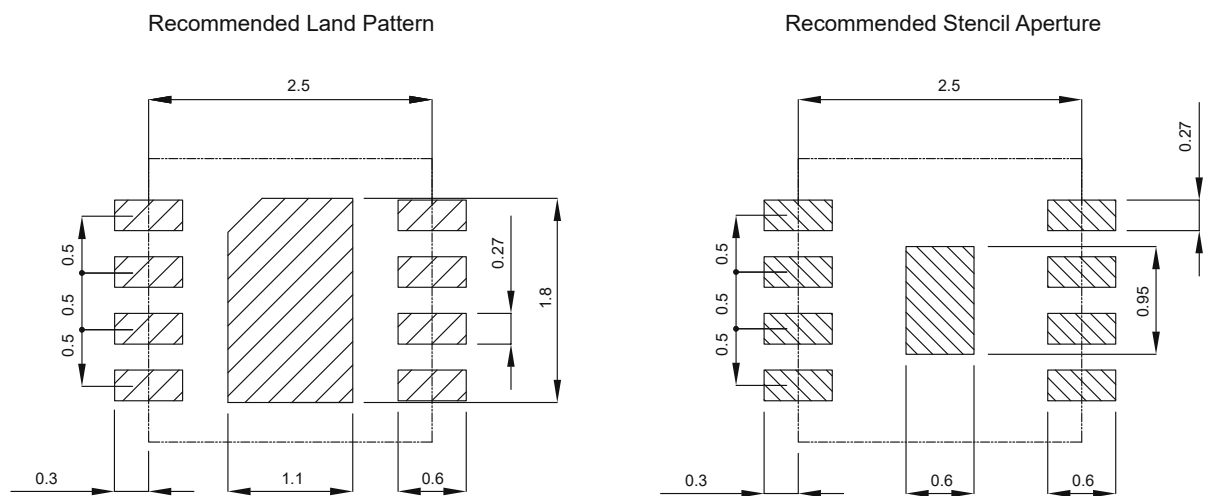

Figure 26: Recommended land pattern and stencil aperture

7 Quality

The TEEEx qualification is performed based on the JEDEC JESD47 qualification test method. The device is fully RoHs and WEEE compliant.

8 Additional Documentation

DOCUMENT	DESCRIPTION	LINK
TEE501 Handling Instructions		www.epluse.com/tee501
TEE501 CRC8 Code Example	Code samples for Arduino and Raspberry PI	https://github.com/Epluse

Table 15: Applicable documentation

9 Revision History

DATE	VERSION	PAGE(S)	CHANGES
March 2022	1.0	1-21	Initial release

Table 16: Revision history