

2-way cartridge valves

Directional functions

Cartridge valves and control covers

RE 21010/03.05
Replaces: 02.03

1/68

Types LC and LFA

Sizes 16 to 160
Component series 2X; 6X; 7X
Maximum operating pressure 420 bar
Maximum flow 25000 L/min



H5591

Control cover type LFA 25 WEA-7X/...
with directional valve type 4WE 6
D6X/EG24N9K4 and cable socket



H5455

Cartridge valve type LC 25 A40E7X/...

Table of contents

Contents

see page 2

Features

- Valve poppet with or without damping nose
- 2 area ratios
- 4 different springs
- 4 stroke limiters
- Control cover with integrated poppet valve
- Control cover with integrated shuttle valve
- Control cover for mounting directional spool valves with or without integrated shuttle valve
- Control cover with or without limit switch monitoring
- Further information:

| Pilot control valves | Size 6 | Size 10 |
|-----------------------------------|----------|----------|
| Directional spool valve type WE | RE 23178 | RE 23327 |
| Directional poppet valve type SEW | RE 22058 | RE 22075 |
| Directional poppet valve type SED | RE 22049 | RE 22045 |

Table of contents

| Contents | Page | Contents | Page |
|---|------|--|------------|
| Features | 1 | Control cover type LFA | |
| Function, sections, symbol | 3 | General notes on the ordering code | 10, 11, 16 |
| Mounting cavity and connection dimensions | 4, 5 | Preferred types | 11 |
| Technical data | 6 | Basic symbols | 12, 13 |
| | | Characteristic curves for the selection of nozzles | 14 |
| | | Material numbers of nozzles and plug screws | 15 |
| Cartridge valve type LC | | Fixing screws | 16 |
| Ordering code | 7 | Symbols and unit dimensions: | |
| Preferred types | 7 | – Type ..D... | 17, 18 |
| Symbols | 7 | – Type ..H... | 19 to 21 |
| Technical data | 8 | – Type ..G... | 22, 23 |
| Characteristic curves | 9 | – Type ..R...; ..RF... | 24, 25 |
| | | – Type ..R...; ..R2... | 26, 27 |
| | | – Type ..WEA..., ..WEB... | 28 to 33 |
| | | – Type ..WEMA..., ..WEMB... | 34 to 37 |
| | | – Type ..WEA8..., ..WEB8... | 38, 39 |
| | | – Type ..WECA... | 40 to 42 |
| | | – Type ..WEA9... | 43 |
| | | – Type ..GWA..., ..GWB... | 44 to 49 |
| | | – Type ..KWA..., ..KWB... | 50 to 55 |
| | | – Type ..E... | 56, 57 |
| | | – Type ..EH2... | 58, 59 |
| | | – Type ..EWA..., ..EWB... | 60 to 65 |
| | | Inductive position switch type QM | 66 |
| | | Cable socket for inductive position switch type QM | 66 |

Function, sections, symbol

2-way cartridge valves are designed as elements for insertion into compact blocks. The power part with ports A and B is installed in a mounting cavity, which is standardised according to DIN ISO 7368, in the block and sealed by means of a cover. In most cases, the cover forms at the same time the connection between the control section of the power part and the pilot control valves. By controlling the power part with appropriate pilot control valves, it can perform pressure control, directional and throttling functions or a combination of these. Particularly economic solutions can be achieved by adapting the sizes to the different flows in the individual channels of an actuator. A very cost-efficient solution can be obtained, if several functions are assigned to the power part of an element.

Directional function

2-way cartridge valves mainly consist of a control cover (1) and a cartridge element (2). The control cover is provided with pilot bores and, depending on the required overall function, optionally a stroke limiter, a hydraulically controlled directional poppet valve or a shuttle valve. Moreover, electrically operated directional spool valves or directional poppet valves can be mounted onto the control cover. The cartridge consists of a bushing (3), a ring (4) (up to size 32 only), a valve poppet (5), optionally with damping nose (6) or without damping nose (7) and a closing spring (8).

Function

2-way cartridge valves operate in dependence upon pressure. Three pressurised areas are essential for the function: A1, A2, A3. The area of the valve seat is always taken as 100%. As a result of the stepping, the annulus area A2 is 7% or 50% of area A1, depending on the version. Consequently, the area ratio A1: A2 is either 14.3:1 or 2:1. Area A3 is equal to the sum of areas A1 + A2. Due to the different area ratios A1: A2 and the resulting different annulus areas (A2), area A3 is either 107% or 150% of area A1 on the seat that is assumed to be 100%.

The following is generally valid:

Areas A1 and A2 act in the direction of opening. Area A3 and the spring act in the direction of closing. The effective direction of the force resulting from the opening and closing forces determines the spool position of the 2-way cartridge valve.

The medium can flow through 2-way cartridge valves from A to B or from B to A. When area A3 is pressurised due to the pilot oil flow from channel B or external pilot oil supply, channel A is leak-free closed.

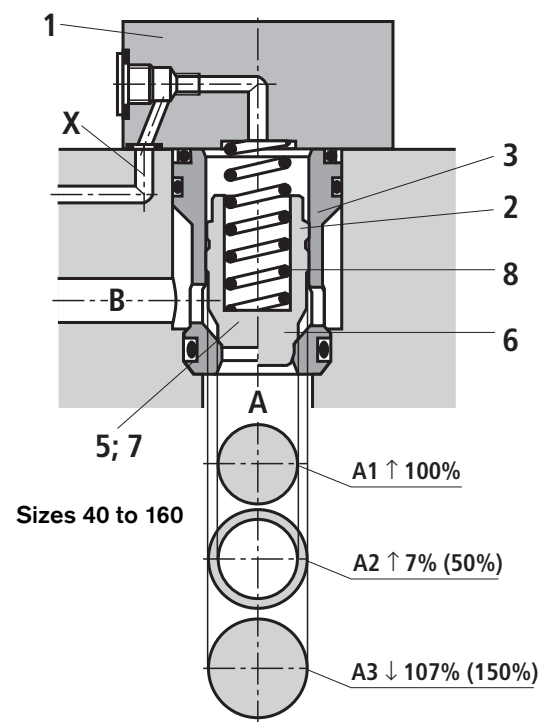
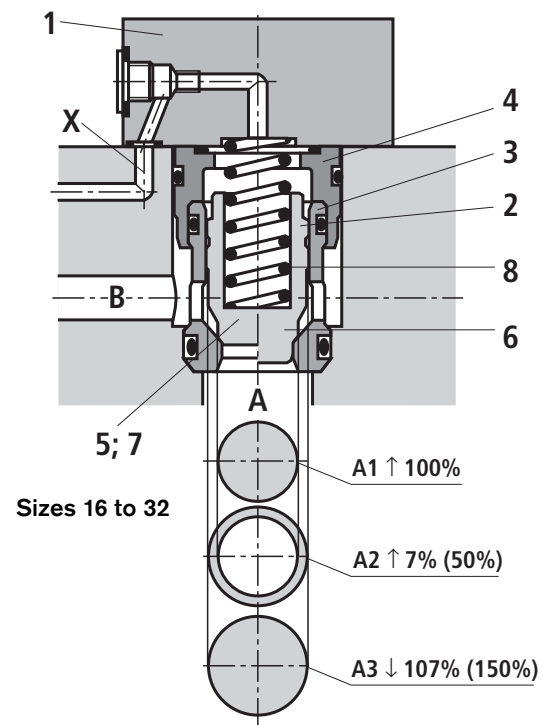
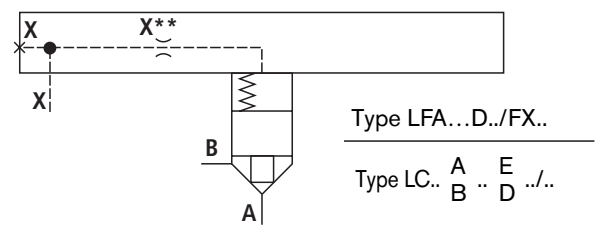

Mounting cavity and connection dimensions to DIN ISO 7368 (except for sizes 125 and 160)
(nominal dimensions in mm)

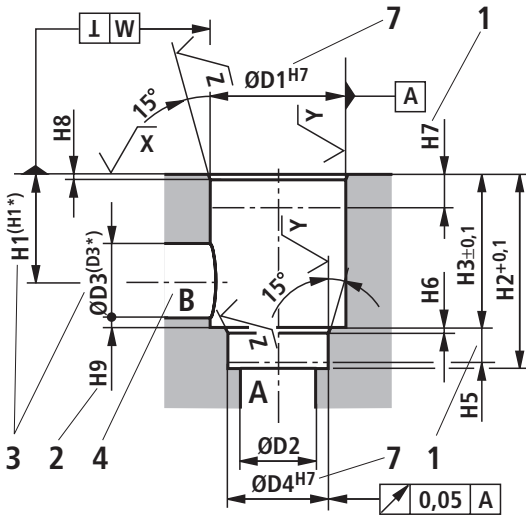

$$\sqrt{X} = \sqrt{Rz1_{max} 4}$$

$$\sqrt{Y} = \sqrt{Rz1_{max} 8}$$

$$\sqrt{Z} = \sqrt{Rz1_{max} 10}$$

For indication of dimensions and explanation of positions, see page 9!

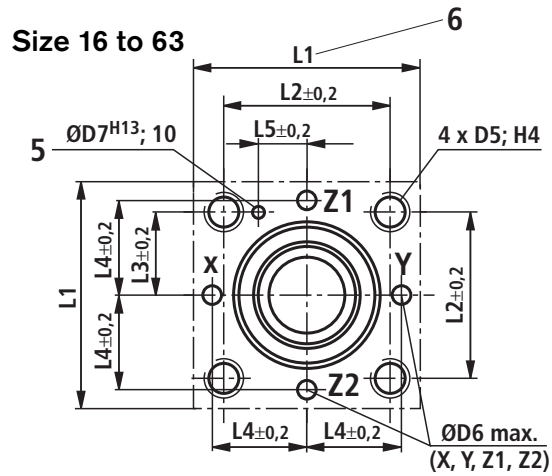

Sizes 80 and 100

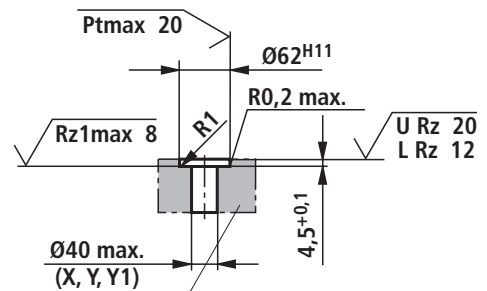
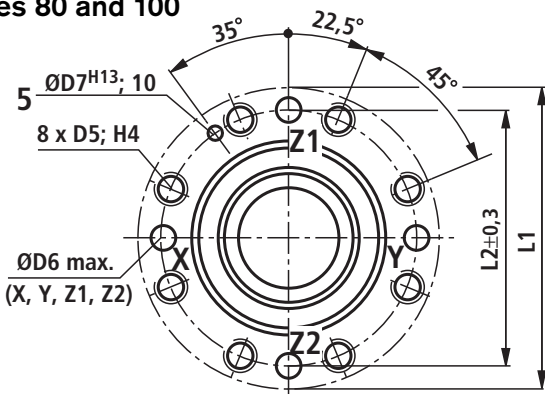

Size 125

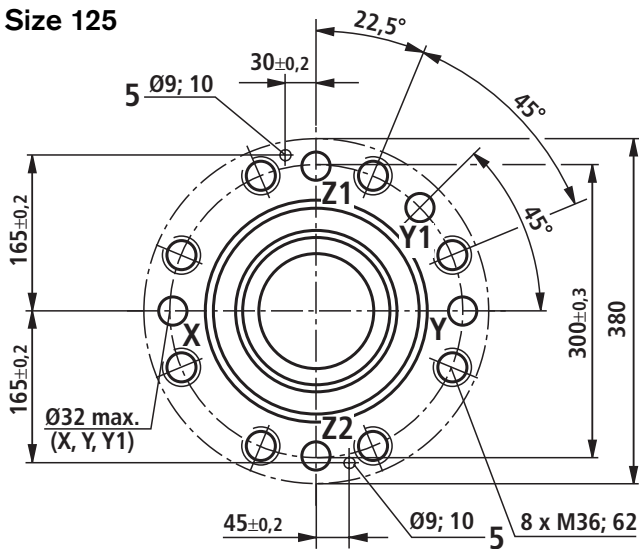

Size 160

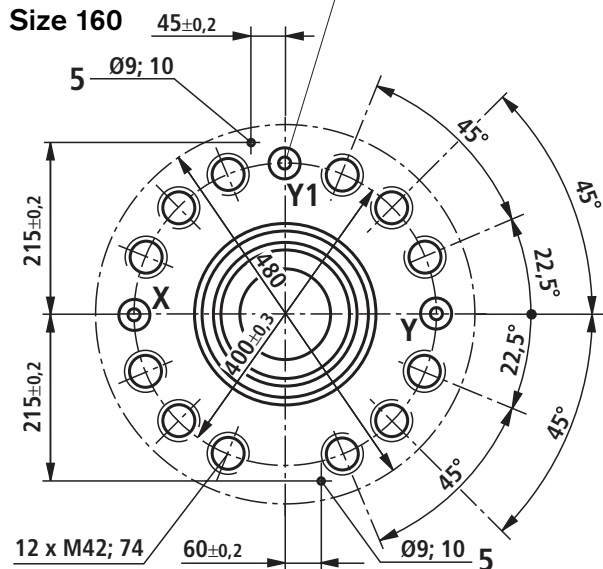

Mounting cavity and connection dimensions to DIN ISO 7368 (except for sizes 125 and 160) (nominal dimensions in mm)

| Size | 16 | 25 | 32 | 40 | 50 | 63 | 80 | 100 | 125 | 160 |
|-------------------|-------|------|-----|------|------|------|---------------------|---------------------|----------------------|----------------------|
| ØD1 | 32 | 45 | 60 | 75 | 90 | 120 | 145 | 180 | 225 | 300 |
| ØD2 | 16 | 25 | 32 | 40 | 50 | 63 | 80 | 100 | 150 ¹⁾ | 200 ¹⁾ |
| ØD3 | 16 | 25 | 32 | 40 | 50 | 63 | 80 | 100 | 125 | 200 |
| (ØD3*) | 25 | 32 | 40 | 50 | 63 | 80 | 100 | 125 | 150 | 250 ¹⁾ |
| ØD4 | 25 | 34 | 45 | 55 | 68 | 90 | 110 | 135 | 200 | 270 |
| ØD5 | M8 | M12 | M16 | M20 | M20 | M30 | M24 | M30 | – | – |
| ØD6 ¹⁾ | 4 | 6 | 8 | 10 | 10 | 12 | 16 | 20 | – | – |
| ØD7 | 4 | 6 | 6 | 6 | 8 | 8 | 10 | 10 | – | – |
| H1 | 34 | 44 | 52 | 64 | 72 | 95 | 130 | 155 | 192 | 268 |
| (H1*) | 29.5 | 40.5 | 48 | 59 | 65.5 | 86.5 | 120 | 142 | 180 | 243 |
| H2 | 56 | 72 | 85 | 105 | 122 | 155 | 205 | 245 | 300 ^{+0.15} | 425 ^{+0.15} |
| H3 | 43 | 58 | 70 | 87 | 100 | 130 | 175 ^{±0.2} | 210 ^{±0.2} | 257 ^{±0.5} | 370 ^{±0.5} |
| H4 | 20 | 25 | 35 | 45 | 45 | 65 | 50 | 63 | – | – |
| H5 | 11 | 12 | 13 | 15 | 17 | 20 | 25 | 29 | 31 | 45 |
| H6 | 2 | 2.5 | 2.5 | 3 | 3 | 4 | 5 | 5 | 7 ^{±0.5} | 8 ^{±0.5} |
| H7 | 20 | 30 | 30 | 30 | 35 | 40 | 40 | 50 | 40 | 50 |
| H8 | 2 | 2.5 | 2.5 | 3 | 4 | 4 | 5 | 5 | 5.5 ^{±0.2} | 5.5 ^{±0.2} |
| H9 | 0.5 | 1 | 1.5 | 2.5 | 2.5 | 3 | 4.5 | 4.5 | 2 | 2 |
| L1 | 65/80 | 85 | 102 | 125 | 140 | 180 | 250 | 300 | – | – |
| L2 | 46 | 58 | 70 | 85 | 100 | 125 | 200 | 245 | – | – |
| L3 | 23 | 29 | 35 | 42.5 | 50 | 62.5 | – | – | – | – |
| L4 | 25 | 33 | 41 | 50 | 58 | 75 | – | – | – | – |
| L5 | 10.5 | 16 | 17 | 23 | 30 | 38 | – | – | – | – |
| W | 0.05 | 0.05 | 0.1 | 0.1 | 0.1 | 0.2 | 0.2 | 0.2 | 0.2 | 0.2 |

¹⁾ Maximum dimension

- 1 Depth of fit
- 2 Reference dimension
- 3 For diameters other than ØD3 or (ØD3*) for port B, the distance from the cover support surface to the centre of the bore must be calculated.
- 4 Port B can be arranged around the central axis of port A. However, care must be taken to ensure that the mounting cavities and the pilot bores are not damaged.
- 5 Drilling for locating pin
- 6 Note on porting pattern for size 16: Length L1 (x–y axis of bores) for control cover with built-on directional valve is 80 mm.
- 7 For $\varnothing \leq 45$ mm → fit H8 permitted!

Technical data (for applications outside these parameters, please consult us!)

| | | |
|---|---------------------------------|--|
| Ambient temperature range | °C | - 20 to + 70 |
| Maximum operating pressure | - Without directional valve | bar 420 |
| | - Ports A, B, X, Z1, Z2 | bar 315; 350: 420 (according to the maximum operating pressure of built-on valves) |
| | - Port Y | bar corresponds to maximum tank pressure of built-on valves |
| | - With monitored spool position | bar 400 |
| Maximum flow | L/min | 25000 (size-dependent; see characteristic curves on page 9) |
| Hydraulic fluid | | Mineral oil (HL, HLP) to DIN 51524 ¹⁾ ; fast bio-degradable hydraulic fluids to VDMA 24568 (see also RE 90221); HETG (rape seed oil) ¹⁾ ; HEPG (polyglycols) ²⁾ ; HEES (synthetic esters) ²⁾ ; other hydraulic fluids on enquiry |
| Hydraulic fluid temperature range | °C | - 20 to + 80 |
| Viscosity range | mm ² /s | 2.8 to 500 |
| Max. permissible degree of contamination of the hydraulic fluid - cleanliness class to ISO 4406 (c) | | Class 20/18/15 ³⁾ |

¹⁾ Suitable for NBR and FKM seals

²⁾ Suitable for FKM seals only

³⁾ The cleanliness classes specified for components must be adhered to in hydraulic systems. Effective filtration prevents

malfunction and, at the same time, increases the service life of components.

For the selection of filters, see data sheets RE 50070, RE 50076, RE 50081, RE 50086 and RE 50088.

Ordering code: Cartridge valve (without control cover)

| LC | | | | | | | | | | | | | | | |
|--|-------|--|--|--|--|--|--|--|--|--|--|--|--|--|--|
| Size 16 (series 7X) | = 16 | | | | | | | | | | | | | | |
| Size 25 (series 7X) | = 25 | | | | | | | | | | | | | | |
| Size 32 (series 7X) | = 32 | | | | | | | | | | | | | | |
| Size 40 (series 7X) | = 40 | | | | | | | | | | | | | | |
| Size 50 (series 7X) | = 50 | | | | | | | | | | | | | | |
| Size 63 (series 7X) | = 63 | | | | | | | | | | | | | | |
| Size 80 (series 6X) | = 80 | | | | | | | | | | | | | | |
| Size 100 (series 6X) | = 100 | | | | | | | | | | | | | | |
| Size 125 (series 2X) | = 125 | | | | | | | | | | | | | | |
| Size 160 (series 2X) | = 160 | | | | | | | | | | | | | | |
| Area ratio 2:1 (annulus area = 50%) | = A | | | | | | | | | | | | | | |
| Area ratio 14x3:1 (annulus area = 7%) | = B | | | | | | | | | | | | | | |
| Cracking pressure approx. 0 bar (without spring) | = 00 | | | | | | | | | | | | | | |
| Cracking pressure approx. 0.5 bar | = 05 | | | | | | | | | | | | | | |
| Cracking pressure approx. 1.0 bar | = 10 | | | | | | | | | | | | | | |
| Cracking pressure approx. 2 bar | = 20 | | | | | | | | | | | | | | |
| Cracking pressure approx. 3 bar (size 125 only) | = 30 | | | | | | | | | | | | | | |
| Cracking pressure approx. 4 bar (not with sizes 125 and 160) | = 40 | | | | | | | | | | | | | | |
| For exact values, see page 8. | | | | | | | | | | | | | | | |

| | |
|-----------|--|
| No code = | NBR seals |
| V = | FKM seals |
| | (Other seals on enquiry) |
| | ⚠ Caution! |
| | Observe compatibility of seals with hydraulic fluid used! |
| 7X = | (Sizes 16 to 63) component series 70 to 79 (70 to 79: unchanged installation and connection dimensions) |
| 6X = | (Sizes 80 and 100) component series 60 to 69 (60 to 69: unchanged installation and connection dimensions) |
| 2X = | (Sizes 125 and 160) component series 20 to 29 (20 to 29: unchanged installation and connection dimensions) |
| E = | Valve poppet without damping nose |
| D = | Valve poppet with damping nose |

Preferred types

| Type LC (cartridge valve) | Material number |
|---------------------------|-----------------|
| LC 16 A20D7X/ | R900912572 |
| LC 16 A20E7X/ | R900910269 |
| LC 16 A40D7X/ | R900912573 |
| LC 16 A40E7X/ | R900912568 |
| LC 16 B20E7X/ | R900912595 |
| LC 25 A20D7X/ | R900912580 |
| LC 25 A20E7X/ | R900910270 |
| LC 25 A40D7X/ | R900912581 |
| LC 25 A40E7X/ | R900912574 |
| LC 25 B20E7X/ | R900912604 |
| LC 25 B40D7X/ | R900912609 |
| LC 25 B40E7X/ | R900912601 |
| LC 32 A20D7X/ | R900912589 |
| LC 32 A20E7X/ | R900906337 |
| LC 32 A40D7X/ | R900909665 |
| LC 32 A40E7X/ | R900909662 |
| LC 32 B20E7X/ | R900912613 |
| LC 32 B40D7X/ | R900912617 |
| LC 32 B40E7X/ | R900912610 |

| Type LC (cartridge valve) | Material number |
|---------------------------|-----------------|
| LC 40 A20D7X/ | R900937999 |
| LC 40 A20E7X/ | R900938000 |
| LC 40 A40D7X/ | R900935732 |
| LC 40 A40E7X/ | R900927973 |
| LC 40 B20E7X/ | R900938007 |
| LC 50 A20D7X/ | R900938026 |
| LC 50 A20E7X/ | R900920273 |
| LC 50 A40D7X/ | R900938027 |
| LC 50 A40E7X/ | R900929935 |
| LC 50 B20E7X/ | R900929665 |
| LC 63 A20D7X/ | R900938058 |
| LC 63 A20E7X/ | R900928826 |
| LC 63 A40D7X/ | R900938059 |
| LC 63 A40E7X/ | R900933230 |
| LC 63 B20E7X/ | R900938064 |

Further preferred types and standard components can be found in the EPS (standard price list).

Symbols: Cartridge valve (for versions, see ordering code)

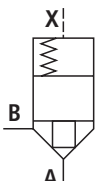
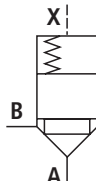
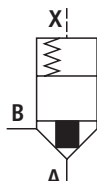
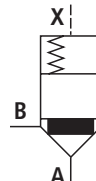
| Without damping nose | | With damping nose | |
|--|---|--|---|
|  <p>Area ratio A1 : A2 = 2 : 1</p> <p>Version ...A..E../...</p> |  <p>Area ratio A1 : A2 = 14.3 : 1</p> <p>Version ...B..E../...</p> |  <p>Area ratio A1 : A2 = 2 : 1</p> <p>Version ...A..D../...</p> |  <p>Area ratio A1 : A2 = 14.3 : 1</p> <p>Version ...B..D../...</p> |

Technical data (for applications outside these parameters, please consult us!)**2-way cartridge valves for directional function**

| | | Size | | | | | | | | | |
|---|-----------------|------|------|-------|-------|-------|-------|-------|------|-------|-------|
| | | 16 | 25 | 32 | 40 | 50 | 63 | 80 | 100 | 125 | 160 |
| Area A1 in cm ² | LC..A.. | 1.89 | 4.26 | 6.79 | 11.1 | 19.63 | 30.2 | 37.9 | 63.6 | 95 | 160.6 |
| | LC..B.. | 2.66 | 5.73 | 9.51 | 15.55 | 26.42 | 41.28 | 52.8 | 89.1 | 133.7 | 224.8 |
| Area A2 in cm ² | LC..A.. | 0.95 | 1.89 | 3.39 | 5.52 | 8.64 | 14.0 | 18.84 | 31.4 | 48 | 79.9 |
| | LC..B.. | 0.18 | 0.43 | 0.67 | 1.07 | 1.85 | 2.90 | 3.94 | 5.9 | 9.3 | 15.7 |
| Area A3 in cm ² | LC..A.. | 2.84 | 6.16 | 10.18 | 16.62 | 28.27 | 44.2 | 56.74 | 95 | 143 | 240.5 |
| | LC..B.. | 2.84 | 6.16 | 10.18 | 16.62 | 28.27 | 44.2 | 56.74 | 95 | 143 | 240.5 |
| Stroke in cm | LC..E.. | 0.9 | 1.17 | 1.4 | 1.7 | 2.1 | 2.3 | 2.4 | 3.0 | 3.8 | 5.0 |
| | LC..D.. | 0.9 | 1.17 | 1.4 | 1.9 | 2.3 | 2.8 | 3.0 | 3.8 | 4.8 | 6.5 |
| Pilot oil volume in cm ³ | LC..E.. | 2.56 | 7.21 | 14.3 | 28.3 | 59.4 | 102 | 136 | 285 | 544 | 1203 |
| | LC..D.. | 2.56 | 7.21 | 14.3 | 31.6 | 65.0 | 124 | 170 | 361 | 687 | 1563 |
| Theoretical pilot flow in L/min ¹⁾ | LC..E.. | 15.4 | 43.3 | 86 | 170 | 356 | 612 | 816 | 1710 | 3264 | 7218 |
| | LC..D.. | 15.4 | 43.3 | 86 | 190 | 390 | 744 | 1020 | 2166 | 4122 | 9378 |
| Weight in kg | Cartridge valve | 0.25 | 0.5 | 1.1 | 1.9 | 3.9 | 7.2 | 13.0 | 27.0 | 44.0 | 75.0 |
| | Control cover | 1.2 | 2.3 | 4.0 | 7.4 | 10.5 | 21.0 | 27.0 | 42.0 | 80.0 | 150.0 |

Cracking pressure in bar

| | | | | | | | | | | | |
|--------------------------------------|------------|-------|-------|-------|-------|-------|------|------|------|------|------|
| Direction of flow from A to B | LC..A 00.. | 0.02 | 0.025 | 0.05 | 0.05 | 0.05 | 0.07 | 0.07 | 0.1 | 0.15 | 0.15 |
| | LC..A 05.. | 0.35 | 0.35 | 0.36 | 0.35 | 0.37 | 0.31 | 0.44 | 0.43 | 0.43 | 0.45 |
| | LC..A 10.. | 0.70 | 0.68 | 0.72 | 0.71 | 0.67 | 0.64 | 0.88 | 0.88 | 0.88 | – |
| | LC..A 20.. | 2.03 | 2.18 | 2.12 | 2.02 | 2.01 | 2.0 | 1.75 | 1.75 | 1.76 | 1.94 |
| | LC..A 30.. | – | – | – | – | – | – | – | – | 2.05 | – |
| | LC..A 40.. | 3.50 | 3.90 | 3.80 | 4.0 | 4.11 | 3.8 | 3.13 | 3.04 | – | – |
| | LC..B 00.. | 0.014 | 0.02 | 0.035 | 0.035 | 0.035 | 0.05 | 0.05 | 0.07 | 0.1 | 0.1 |
| | LC..B 05.. | 0.25 | 0.26 | 0.26 | 0.25 | 0.28 | 0.23 | 0.31 | 0.31 | 0.31 | 0.32 |
| | LC..B 10.. | 0.49 | 0.50 | 0.51 | 0.51 | 0.48 | 0.47 | 0.63 | 0.63 | 0.62 | – |
| | LC..B 20.. | 1.44 | 1.62 | 1.52 | 1.44 | 1.5 | 1.5 | 1.26 | 1.25 | 1.25 | 1.4 |
| Direction of flow from B to A | LC..A 00.. | 0.04 | 0.05 | 0.1 | 0.1 | 0.1 | 0.14 | 0.14 | 0.2 | 0.30 | 0.33 |
| | LC..A 05.. | 0.69 | 0.78 | 0.72 | 0.7 | 0.84 | 0.68 | 0.88 | 0.88 | 0.86 | 0.91 |
| | LC..A 10.. | 1.38 | 1.53 | 1.42 | 1.43 | 1.47 | 1.37 | 1.77 | 1.78 | 1.73 | – |
| | LC..A 20.. | 4.05 | 4.91 | 4.25 | 4.06 | 4.57 | 4.33 | 3.53 | 3.54 | 3.50 | 3.9 |
| | LC..A 30.. | – | – | – | – | – | – | – | – | 4.0 | – |
| | LC..A 40.. | 6.96 | 8.74 | 7.6 | 8.05 | 9.34 | 8.15 | 6.3 | 6.2 | – | – |
| | LC..B 00.. | 0.24 | 0.25 | 0.5 | 0.5 | 0.5 | 0.8 | 0.7 | 1.0 | 1.5 | 1.5 |
| | LC..B 05.. | 3.69 | 3.40 | 3.64 | 3.64 | 3.95 | 3.27 | 4.2 | 4.6 | 4.4 | 4.6 |
| | LC..B 10.. | 7.43 | 6.69 | 7.24 | 7.37 | 6.88 | 6.62 | 8.4 | 9.4 | 8.9 | – |
| | LC..B 20.. | 21.3 | 21.5 | 21.6 | 20.9 | 21.4 | 20.9 | 16.9 | 18.7 | 17.9 | 20 |
| LC..B 30.. | – | – | – | – | – | – | – | – | 20.7 | – | |
| LC..B 40.. | 36.6 | 38.3 | 38.6 | 41.5 | 43.6 | 39.4 | 30.2 | 32.5 | – | – | |

¹⁾ with a switching time of 10 ms

Characteristic curves (measured with HLP46, $\vartheta_{oil} = 40 \text{ }^\circ\text{C} \pm 5 \text{ }^\circ\text{C}$)

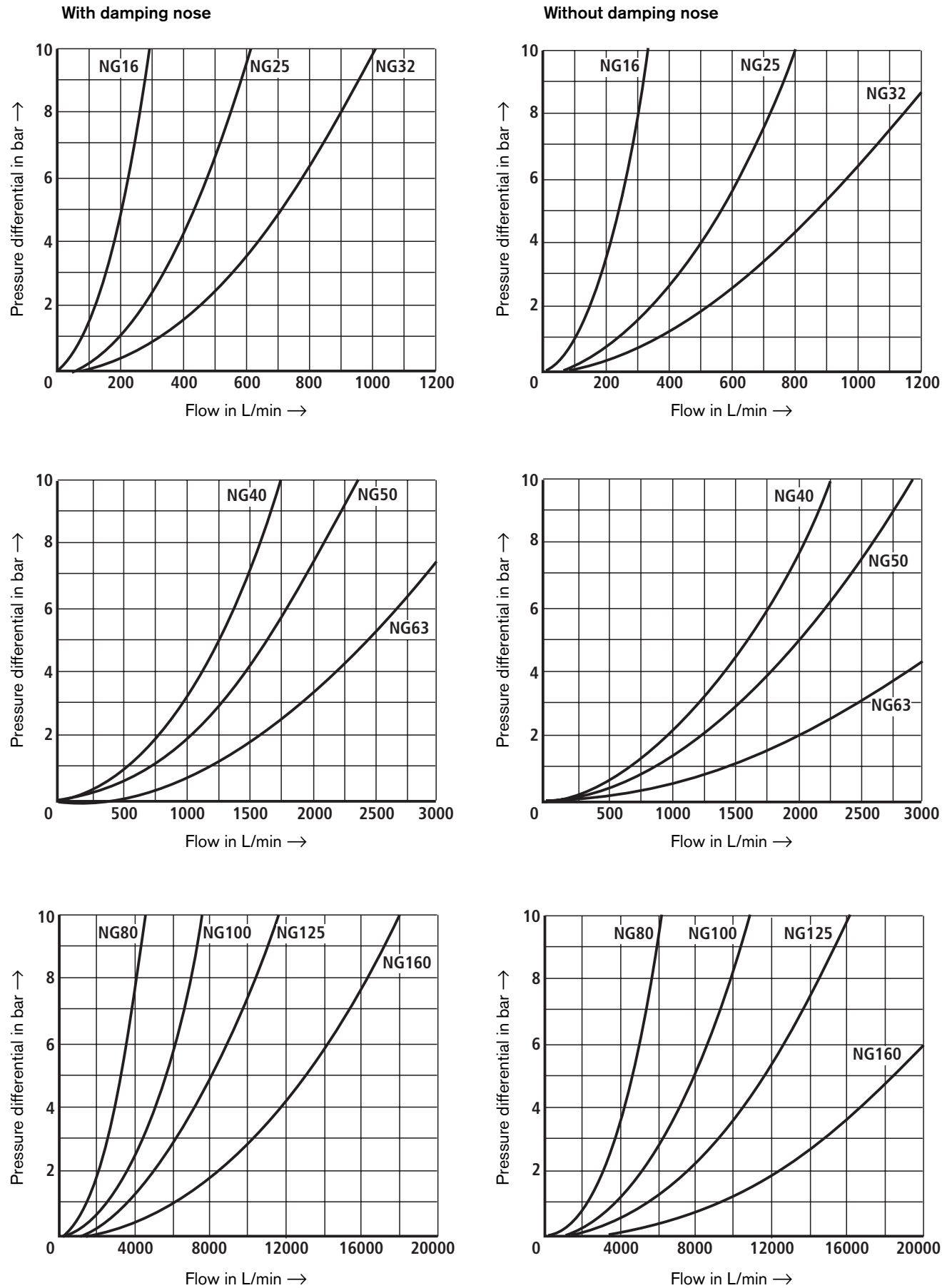

General notes on the ordering code for control covers

x = available
 • = on enquiry

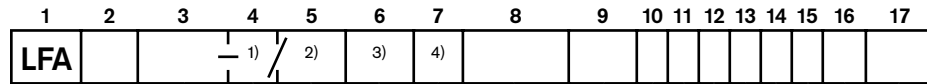



| Size | | | | | | | | | | Type | Component series | Area ratio | Cracking pressure | Damping | El. monitor for closed position | Remote control port | Nozzles in channel ⁵⁾ | | | | | | | Seal material | | | | |
|------|----|----|----|----|----|----|-----|-----|-----|-------------|------------------|------------|-------------------|---------|---------------------------------|---------------------|----------------------------------|---|---|---|---|---|----|---------------|--|--|---|--|
| 16 | 25 | 32 | 40 | 50 | 63 | 80 | 100 | 125 | 160 | | | | | | | | A | B | P | T | X | F | Z1 | | | | | |
| x | x | x | x | x | x | | | | | | 7X | | | | | | | | | | | | | | | | The ordering code can be found on the relevant pages of the individual control cover variants | |
| | | | | | | x | x | | | | 6X | | | | | | | | | | | | | | | | | |
| | | | | | | | | x | x | | 2X | | | | | | | | | | | | | | | | | |
| | | | | | | | | | | | | | | | | | | | | | | | | | | | | |
| x | x | x | x | x | x | x | x | x | x | D | | | | | | F | | | | | | x | | | | | | |
| x | x | x | x | | | | | | | H1 | | | | | | F | | | | | | x | | | | | | |
| x | x | x | x | x | x | x | x | x | x | H2 | | | | | | F | | | | | | x | | | | | | |
| x | x | x | x | | | | | | | H3 | | | | | | F | | | | | | x | | | | | | |
| x | x | x | x | x | x | x | x | | | H4 | | | | | | F | | | | | | x | | | | | | |
| x | x | x | x | x | x | x | x | | | G | | | | | | | | | | | | x | | x | | | | |
| | x | x | x | x | x | x | x | | | R | | | | | | | | | | | | | x | | | | | |
| | x | x | x | x | x | | | | | RF | | | | | | | | | | | | | x | | | | | |
| | | | | | | x | x | | | R2 | | | | | | | | | | | | | x | | | | | |
| x | x | x | x | x | x | x | x | • | • | WEA | | | | | | | x | | x | x | | | | | | | | |
| x | x | x | x | x | x | x | x | • | • | WEB | | | | | | | | x | x | x | | | | | | | | |
| x | x | x | x | x | x | | | | | WEMA | | | | | | | | | x | x | | | x | | | | | |
| | | | | | | x | x | | | WEA8 | | | | | | | | | x | x | | | x | | | | | |
| x | x | x | x | x | x | | | | | WEMB | | | | | | | | | x | x | | | x | | | | | |
| | | | | | | x | x | | | WEB8 | | | | | | | | | x | x | | | x | | | | | |
| x | x | x | x | x | x | | | | | WECA | | | | | | | x | x | x | x | | | | | | | | |
| | | | | | | x | x | | | WEA9 | | | | | | | x | x | x | x | | | | | | | | |
| x | x | x | x | x | x | x | x | | | GWA | | | | | | | x | | x | x | | | | | | | | |
| x | x | x | x | x | x | x | x | | | GWB | | | | | | | | x | x | x | | | | | | | | |
| x | x | x | x | x | x | x | x | | | KWA | | | | | | | x | | | | | | | | | | | |
| x | x | x | x | x | x | x | x | | | KWB | | | | | | | | x | | | | | | | | | | |
| x | x | x | x | x | x | • | • | • | • | E | | x | x | D | QMG24 | F | | | | | | | x | | | | | |
| x | x | x | x | x | x | • | • | | | EH2 | | x | x | D | QMG24 | F | | | | | | | x | | | | | |
| x | x | x | x | x | x | | | | | EWA | | x | x | D | QMG24 | | x | | x | x | | | | | | | | |
| x | x | x | x | x | x | | | | | EWB | | x | x | D | QMG24 | | | | x | x | x | | | | | | | |

1) **7X** = component series 70 to 79,
6X = component series 60 to 69 and
2X = component series 20 to 29: (unchanged installation and connection dimensions)
 2) **CA** = 2 : 1 (area ratio A1:A2)
CB = 14.3 : 1 (area ratio A1:A2)
CD = 0 %
 For the control cover with electrical monitor of the closed position (including position switch), the type designation includes the version of the control cover and the cartridge valve).





3) **10** = 1.0 bar cracking pressure
20 = 2.0 bar cracking pressure
40 = 4.0 bar cracking pressure
 4) **D** = valve poppet of the cartridge with damping nose
 5) Order of nozzles for the purchase order and representation in symbols and circuit diagrams.
 Further details can be found on the relevant pages of the individual control cover variants and on page 14 (nozzle characteristic curves).

Preferred types, see page 11, are available at short notice!

General notes on the ordering code for control covers

| Nozzle symbol | | Symbol in the ordering code | |
|--|---|-----------------------------|---|
| A** |  | A** |  |
| <p>This nozzle is designed as screw-in nozzle. If a nozzle is to be installed, the relevant code letter must be entered in the type designation together with the nozzle Ø in 1/10 mm. Example: A12 = nozzle with Ø1.2 mm in channel A.</p> | | | |

For pilot control valves, see page 16!

| Nozzle symbol | | Symbol in the ordering code | |
|--|---|-----------------------------|---|
| Ø1,2 |  | |  |
| <p>This nozzle is designed as a drilling; no entries are required in the type designation. (Nozzle Ø in mm)</p> | | | |
| Nozzle symbol | | Symbol in the ordering code | |
| Z12 |  | |  |
| <p>This nozzle is designed as threaded nozzle. It is a standard nozzle, for which no entries are required in the type designation. (Nozzle Ø in 1/10 mm)</p> | | | |

Preferred types

| Type LFA (control cover) | Material number |
|--------------------------|-----------------|
| LFA 16 D-7X/F | R900912625 |
| LFA 16 H2-7X/F | R900912655 |
| LFA 16 WEA-7X/ | R900910271 |
| LFA 16 GWA-7X/ | R900912636 |
| LFA 16 E-7X/CA40DQMG24F | R900912619 |
| LFA 25 D-7X/F | R900905302 |
| LFA 25 H2-7X/F | R900912694 |
| LFA 25 WEA-7X/ | R900910273 |
| LFA 25 GWA-7X/ | R900912675 |
| LFA 25 E-7X/CA40DQMG24F | R900912670 |
| LFA 32 D-7X/F | R900905303 |
| LFA 32 H2-7X/F | R900912728 |
| LFA 32 WEA-7X/ | R900912712 |
| LFA 32 GWA-7X/ | R900912708 |
| LFA 32 E-7X/CA40DQMG24F | R900912703 |

| Type LFA (control cover) | Material number |
|--------------------------|-----------------|
| LFA 40 D-7X/F | R900938073 |
| LFA 40 H2-7X/F | R900938122 |
| LFA 40 WEA-7X/ | R900931581 |
| LFA 40 GWA-7X/ | R900938114 |
| LFA 40 E-7X/CA40DQMG24F | R900938107 |
| LFA 50 D-7X/F | R900938150 |
| LFA 50 H2-7X/F | R900938205 |
| LFA 50 WEA-7X/ | R900938215 |
| LFA 50 GWA-7X/ | R900938200 |
| LFA 50 E-7X/CA40DQMG24F | R900938197 |
| LFA 63 D-7X/F | R900938225 |
| LFA 63 H2-7X/F | R900938250 |
| LFA 63 WEA-7X/ | R900938257 |
| LFA 63 GWA-7X/ | R900938245 |
| LFA 63 E-7X/CA40DQMG24F | R900938242 |

Further preferred types and standard components can be found in the EPS (standard price list).

Symbols (basic symbols)

The symbols used in the description of types below are binding!

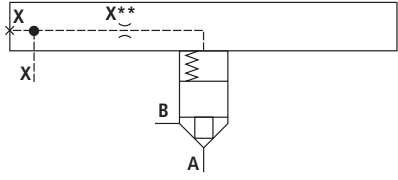
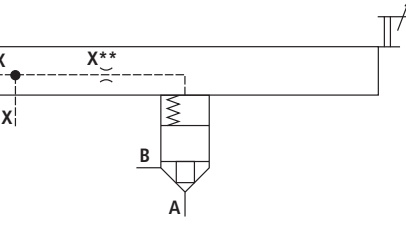
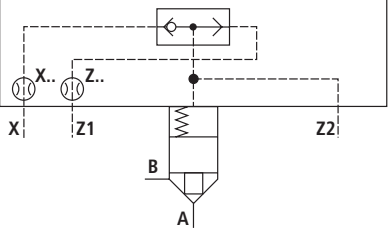
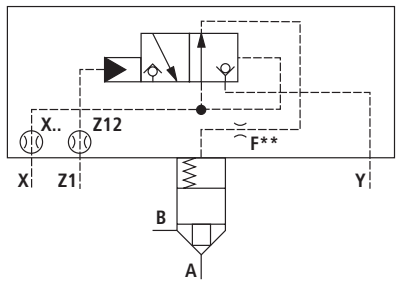
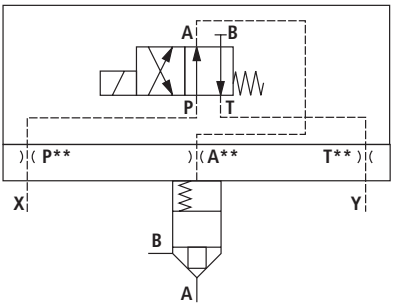
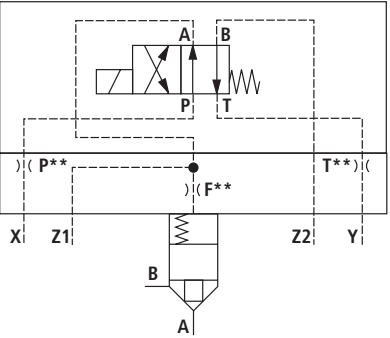
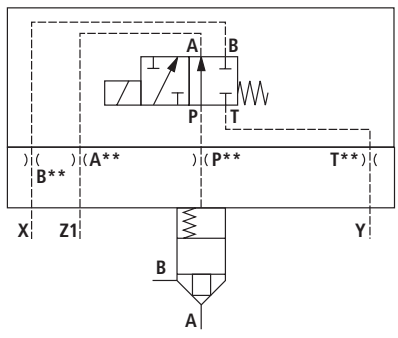
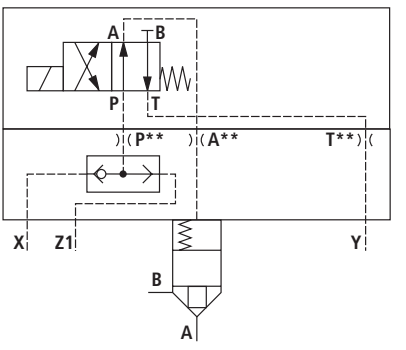
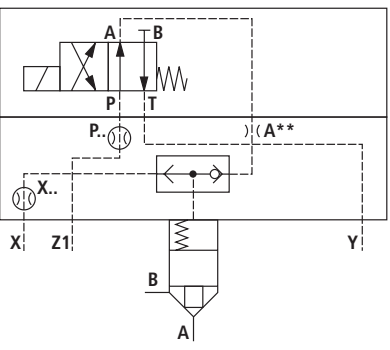
| | | |
|---|--|--|
| <p>LFA . D-../F... Control cover with remote control port Sizes 16 to 160 Pages 17 and 18</p>  | <p>LFA . H-../F... Control cover with stroke limiter, with remote control port Sizes 16 to 160 Pages 19 to 21</p>  | <p>LFA . G-../... Control cover with integrated shuttle valve Sizes 16 to 100 Pages 22 and 23</p>  |
| <p>LFA . R-../... Control cover with integrated pilot operated pilot control valve (directional poppet valve) Sizes 25 to 100 Pages 24 to 27</p>  | <p>LFA . WEA-../... Control cover for mounting a directional spool or poppet valve Sizes 16 to 160 Pages 28 to 33</p>  | <p>LFA . WEMA-../...; LFA . WEA8-../... Control cover for mounting a directional spool or poppet valve with pilot ports for operating a 2nd valve Sizes 16 to 100 Pages 34 to 39</p>  |
| <p>LFA . WECA-../...; LFA . WEA9-../... Control cover for mounting a directional spool valve as check valve circuit Sizes 16 to 100 Pages 40 to 43</p>  | <p>LFA . GWA-../... Control cover for mounting a directional spool or poppet valve, with integrated shuttle valve Sizes 16 to 100 Pages 44 to 49</p>  | <p>LFA . KWA-../... Control cover for mounting a directional spool or poppet valve, with integrated shuttle valve as check valve circuit Sizes 16 to 100 Pages 50 to 55</p>  |

Symbols (basic symbols)

The symbols used in the description of types below are binding!

LFA . E-../..DQMG24F...

Control cover with electrical monitor for the closed position, including cartridge insert

Sizes 16 to 160

Pages 56 and 57

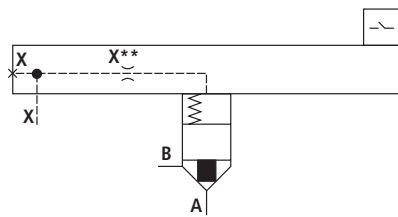

LFA . EH2-../..DQMG24F...

Control cover with electrical monitor for the closed position and stroke limiter, including cartridge insert

Sizes 16 to 100

Pages 58 and 59

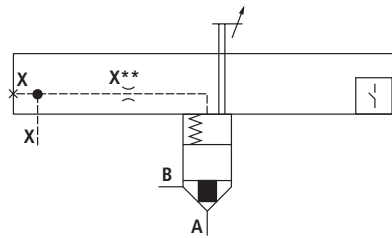

LFA . EWA-../..DQMG24...

Control cover with electrical monitor for the closed position, for mounting a directional spool or poppet valve, including cartridge insert

Sizes 16 to 63

Pages 60 to 65

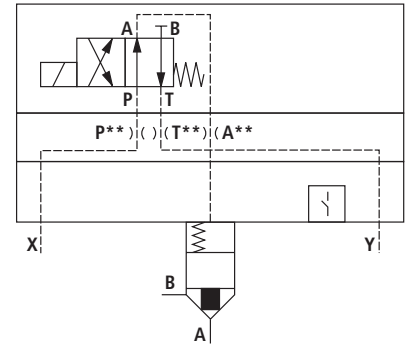

Characteristic curves for the selection of nozzles

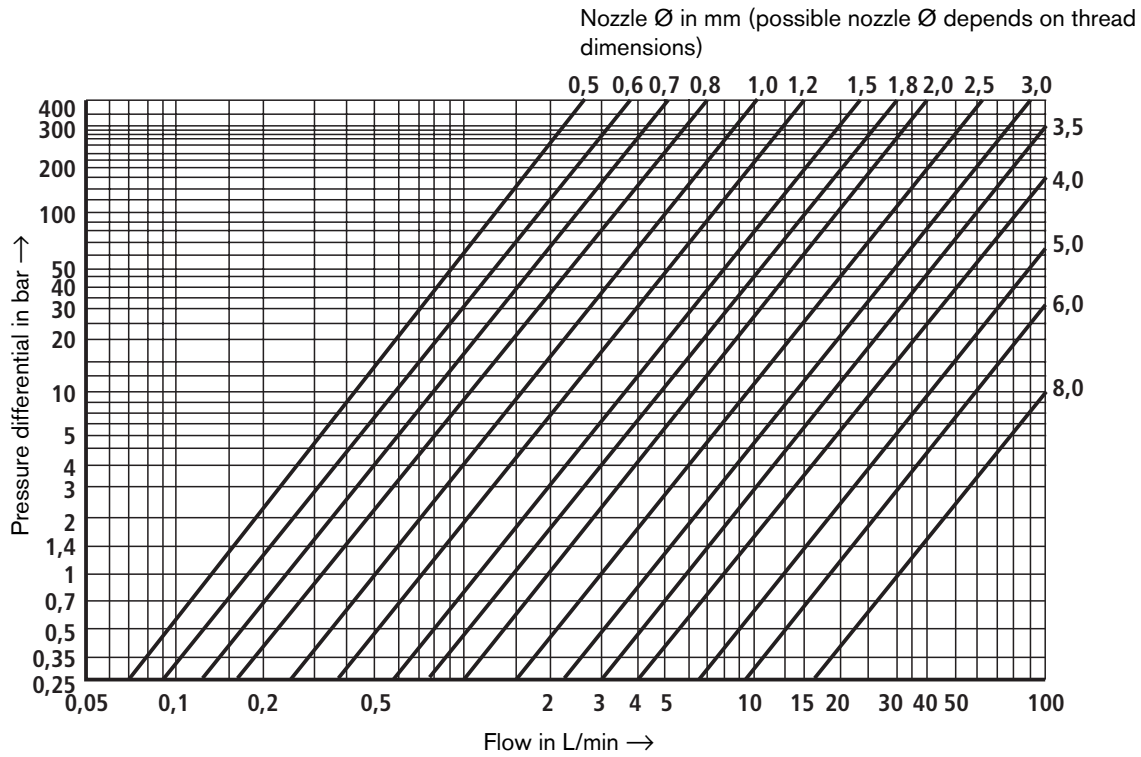

| Thread | Nozzle Ø in mm |
|-------------|----------------|
| M6 tap. | 0.5 to 3.0 |
| M8 x 1 tap. | 0.5 to 4.0 |
| G3/8 | 0.8 to 6.0 |
| G1/2 | 1.0 to 8.0 |

Material numbers of nozzles and plug screws

| Standard nozzle for size | Nozzle Ø in mm | Material number | | | |
|-----------------------------|-------------------|-----------------|-------------|------------|------------|
| | | M6 tap. | M8 x 1 tap. | G3/8 | G1/2 |
| | 0.5 | R900157933 | R900157930 | – | – |
| | 0.6 | R900157934 | R900149430 | – | – |
| | 0.7 | R900157931 | R900143957 | – | – |
| 16 | 0.8 | R900152276 | R900136843 | R900159043 | – |
| 25 | 1.0 | R900149335 | R900136842 | R900159033 | R900139115 |
| 32 | 1.2 | R900152286 | R900139101 | R900159032 | R900150714 |
| 40 | 1.5 | R900148823 | R900133712 | R900159031 | R900139117 |
| 50 | 1.8 | R900157932 | R900150953 | R900159030 | R900159026 |
| 63 and 80 | 2.0 | R900156650 | R900137299 | R900159029 | R900148352 |
| 100 | 2.5 | R900157929 | R900137445 | R900146259 | R900148353 |
| | 3.0 | R900181894 | R900144761 | R900149044 | R900148361 |
| | 3.5 | – | R900136079 | R900146258 | R900159027 |
| | 4.0 | – | R900802480 | R900149052 | R900149939 |
| | 5.0 | – | – | R900152287 | R900143775 |
| | 6.0 | – | – | R900135774 | R900147875 |
| | 8.0 | – | – | – | R900159028 |
| Plug screw | | R900023986 | R900003443 | R900006325 | R900006445 |

General notes on the ordering code for control covers (pilot control valves)

| Pilot control valve | Size | Data sheet no. | Control cover type | Size (control cover) | |
|-----------------------------------|--|----------------|--------------------|--|-----------|
| Type | | | | | |
| Directional spool valve (wet pin) | 4WE 6 D...6X/E | 6 | 23178 | WEA, WEB, GWA, GWB, KWA, KWB, EWA, EWB, WEMA, WEMB | 16 to 50 |
| | 3WE 6 A...6X/E | 6 | 23178 | WECA | 16 to 50 |
| | 4WE 10 D...3X/E | 10 | 23327 | WEA, WEB, GWA, KWA, KWB, EWA, EWB | 63 to 100 |
| | 4WE 10 A...3X/E | 10 | 23327 | WEA 9, WECA | 63 to 100 |
| Directional poppet valve | M-3SED 6 UK../350 M-3SED 6 CK../350 | 6 | 22049 | WEMA, WEA, GWA, KWA | 16 to 50 |
| | M-3SEW 6 U../420 M-3SEW 6 C../420 | 6 | 22058 | WEA, GWA, KWA, EWA, WEMA | 16 to 50 |
| | M-3SED 10 UK../350 M-3SED 10 CK../350 | 10 | 22045 | WEA, GWA, KWA | 63 to 100 |
| | M-3SEW 10 U../420 M-3SEW 10 C../420 | 10 | 22075 | WEA, GWA, KWA, EWA | 63 to 100 |

Pilot control valves must be ordered separately.
For more details, see data sheet.

Valve fixing screws are included in the scope of supply of the control cover.

Note!

By combining a 2-way cartridge valve with a pilot control valve, various valve functions can be realised. In particular, the following components with porting pattern to ISO 4401-03-02-0-94 (up to size 50) and ISO 4401-05-04-0-94 (sizes 63 to 100) are suitable for this purpose.

Fixing screws ¹⁾ (included in the scope of supply)

| Size | Control cover type | Qty | Dimensions | Tightening torque M_T in Nm ³⁾ |
|------|--------------------|-----|------------|---|
| 16 | WE., GW. | 4 | M8 x 45 | 32 |
| | WEM. | | M8 x 70 | |
| | E | | M8 x 60 | |
| | EH2 | | M8 x 80 | |
| | EW. | | M8 x 85 | |
| | ²⁾ | | M8 x 40 | |
| 25 | E | 4 | M12 x 60 | 110 |
| | EH2, EW. | | M12 x 90 | |
| | ²⁾ | | M12 x 50 | |
| 32 | H1, H2, E | 4 | M16 x 80 | 270 |
| | H3, H4 | | M16 x 70 | |
| | EH2, EW. | | M16 x 110 | |
| | ²⁾ | | M16 x 60 | |
| 40 | E, EW. | 4 | M20 x 120 | 520 |
| | EH2 | | M20 x 200 | |
| | H1, H2 | | M20 x 110 | |
| | ²⁾ | | M20 x 70 | |

| Size | Control cover type | Qty | Dimensions | Tightening torque M_T in Nm ³⁾ |
|------|------------------------------|-----|------------|---|
| 50 | H2, H4 | 4 | M20 x 120 | 520 |
| | E, EW. | | M20 x 130 | |
| | EH2 | | M20 x 210 | |
| | ²⁾ | | M20 x 80 | |
| 63 | H2, H4 | 4 | M30 x 150 | 1800 |
| | E, EW. | | M30 x 180 | |
| | EH2 | | M30 x 250 | |
| | ²⁾ | | M30 x 100 | |
| 80 | H2, H4 | 8 | M24 x 120 | 900 |
| | ²⁾ | | M24 x 100 | |
| 100 | D, WE. | 8 | M30 x 120 | 1800 |
| | ²⁾ | | M30 x 140 | |
| 125 | All control covers available | 8 | M36 x 160 | 3100 |
| 160 | All control covers available | 12 | M42 x 220 | 5000 |

¹⁾ Hexagon socket head cap screws to ISO 4762 - 10.9

²⁾ Other available standard control covers

³⁾ Calculated with a total coefficient of friction $\mu = 0.14$; must be adjusted for other surfaces

Control cover with or without remote control port: Type ..D... (nominal dimensions in mm)

Sizes 16 to 63

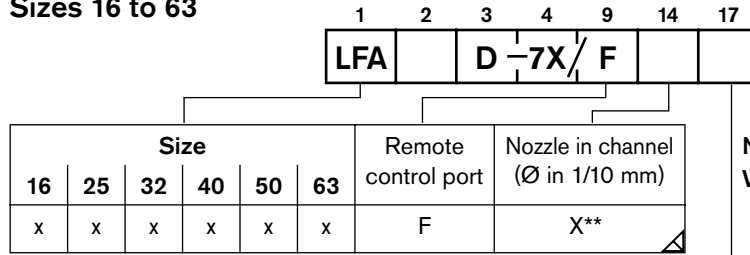

△ Nozzle possible; indicate, if required

No code =
V =

NBR seals
FKM seals
(other seals on enquiry)

⚠ Caution!

Observe compatibility of seals with the hydraulic fluid used!

Type LFA . D.../F

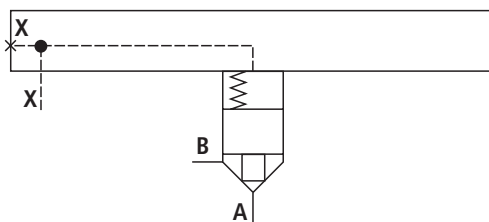

Type LFA . D.../FX**

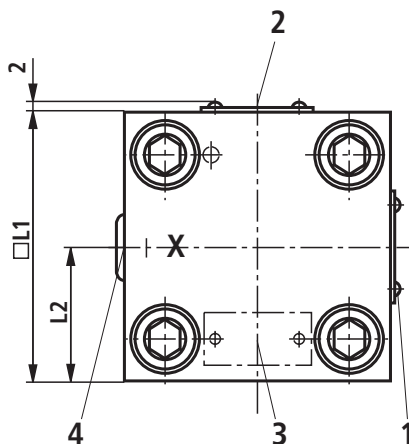
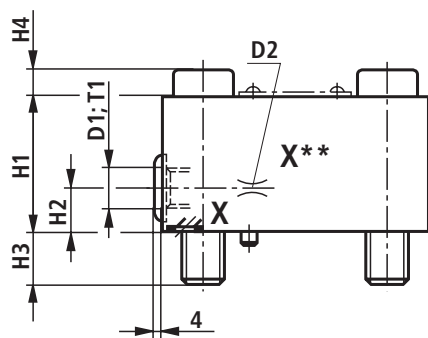
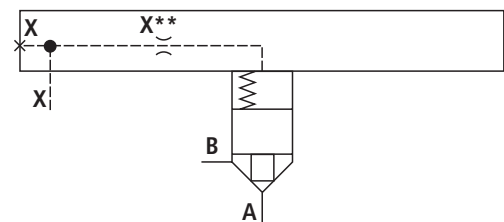

| Size | 16 | 25 | 32 | 40 | 50 | 63 |
|------------------|------|------|------|--------|--------|------|
| D1 | G1/8 | G1/4 | G1/4 | G1/2 | G1/2 | G3/4 |
| D2 ¹⁾ | M6 | M6 | M6 | M8 x 1 | M8 x 1 | G3/8 |
| H1 | 27 | 30 | 35 | 60 | 68 | 82 |
| H2 | 12 | 16 | 16 | 30 | 32 | 40 |
| H3 | 15 | 24 | 28 | 32 | 34 | 50 |
| H4 | 8 | 12 | 16 | - | - | - |
| □ L1 | 65 | 85 | 100 | 125 | 140 | 180 |
| L2 | 32,5 | 42,5 | 50 | 72 | 80 | 90 |
| T1 | 8 | 12 | 12 | 14 | 14 | 16 |

¹⁾ For ordering codes for nozzles, see pages 14 and 15.

- 1 Nameplate for sizes 16, 25
- 2 Nameplate for size 32
- 3 Nameplate for sizes 40, 50, 63
- 4 Port X optionally as threaded connection

Control cover with or without remote control port: Type ..D... (nominal dimensions in mm)

Sizes 80 to 160

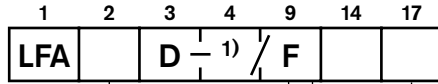

| Size | | | | Remote control port | Nozzle in channel (Ø in 1/10 mm) |
|------|-----|-----|-----|---------------------|----------------------------------|
| 80 | 100 | 125 | 160 | | |
| x | x | x | x | F | X** |

△ Nozzle possible; indicate, if required

- 1) 6X = series 6X (sizes 80, 100)
- 2X = series 2X (sizes 125, 160)

No code =
V =

NBR seals
FKM seals
(Other seals on enquiry)

⚠ Caution!

Observe compatibility of seals with hydraulic fluid used!

Type LFA . D.../F

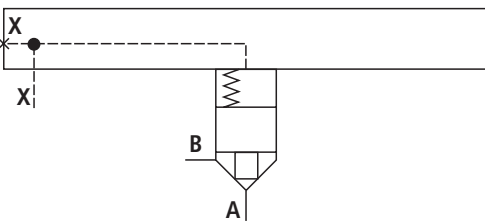

Type LFA . D.../FX**

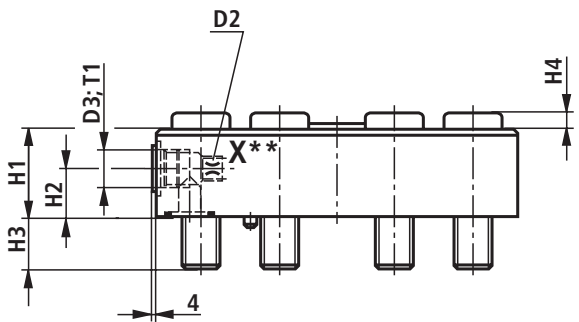
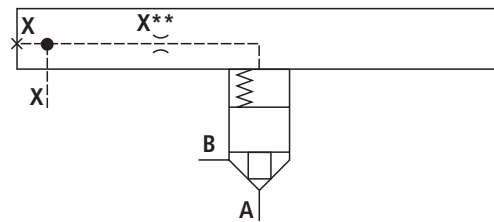

| Size | 80 | 100 | 125 | 160 |
|------------------|------|------|--------|--------|
| D1 | 250 | 300 | 380 | 480 |
| D2 | G3/8 | G1/2 | G1 | G1 |
| D3 ²⁾ | G3/4 | G1 | G1 1/4 | G1 1/4 |
| H1 | 70 | 75 | 105 | 147 |
| H2 | 35 | 40 | 50 | 70 |
| H3 | 45 | 52,5 | 61 | 74 |
| H4 | - | 24 | 31 | 42 |
| T1 | 16 | 18 | 20 | 20 |

²⁾ For ordering codes for nozzles, see page 14 and 15.

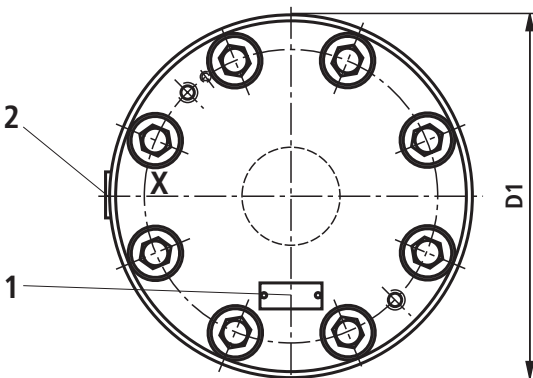

- 1 Nameplate
- 2 Port X optionally as threaded connection

Control cover with stroke limiter and remote control port: Type ..H... (nominal dimensions in mm)

Size 16 to 40

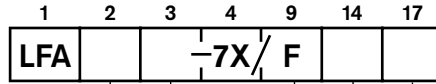

| Size | | | | Control | Remote control port | Nozzle in channel (Ø in 1/10 mm) |
|------|----|----|----|---------|---------------------|----------------------------------|
| 16 | 25 | 32 | 40 | | | |
| x | x | x | x | H1 | F | X** |
| x | x | x | x | H2 | F | X** |
| x | x | x | x | H3 | F | X** |
| x | x | x | x | H4 | F | X** |

No code = V =

NBR seals
FKM seals
(Other seals on enquiry)

⚠ Caution!

Observe compatibility of seals with hydraulic fluid used!

⚠ Nozzle possible; indicate, if required

Type LFA . H.../F

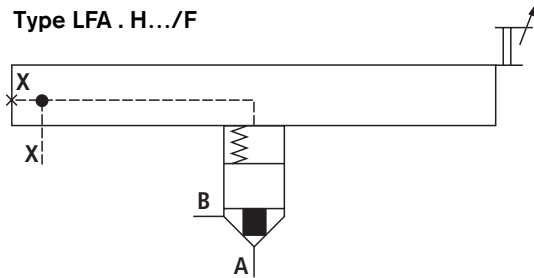

Type LFA . H.../FX**

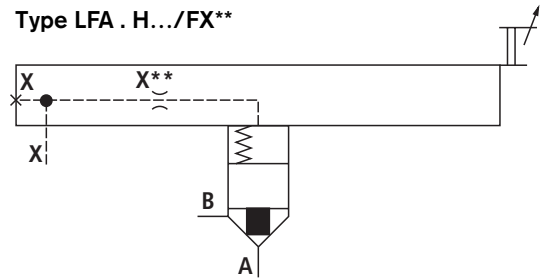

Control "H1"

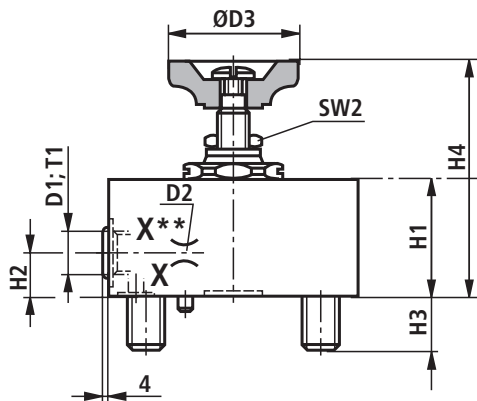

Control "H2"

Sizes 16 and 25 Sizes 32 and 40

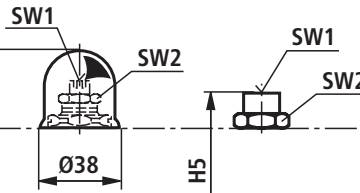

Control "H3"

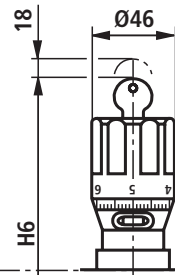

Control "H4"

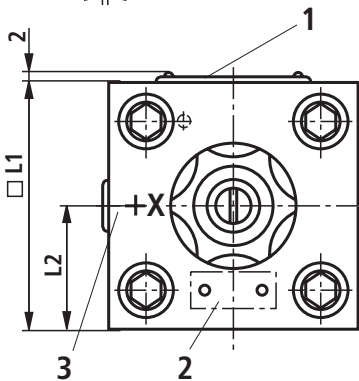
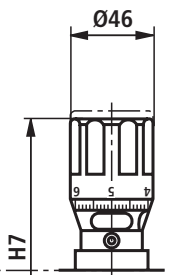

1) For ordering codes for nozzles, see page 14 and 15.

2) Dimensions () valid only for controls "H3" and "H4"

3) Hexagon socket

- 1 Nameplate for sizes 16, 25, 32
- 2 Nameplate for size 40
- 3 Port X optionally as threaded connection

| Size | 16 | 25 | 32 | 40 |
|--------------------|------|------|------------------------|-------------------------|
| D1 | G1/8 | G1/4 | G1/4 | G1/2 |
| D2 ¹⁾ | M6 | M6 | M6 | M8 x 1 |
| ØD3 | 52 | 80 | 80 | 100 |
| H1 | 35 | 40 | 75 (60 ²⁾) | 95 (100 ²⁾) |
| H2 | 12 | 16 | 16 | 30 |
| H3 | 15 | 24 | 28 | 32 |
| H4 max | 90 | 95 | 120 | 160 |
| H5 max | 76 | 80 | 100 | 146 |
| H6 max | 155 | 160 | 180 | 234 |
| H7 max | 130 | 135 | 155 | 209 |
| □ L1 | 65 | 85 | 100 | 125 |
| L2 | 32.5 | 42.5 | 50 | 72 |
| T1 | 8 | 12 | 12 | 14 |
| A/F1 ³⁾ | 6 | 6 | 10 | 14 |
| A/F2 | 21 | 22 | 27 | 46 |

Control cover with stroke limiter and remote control port: Type ..H... (nominal dimensions in mm)

Sizes 50 and 63

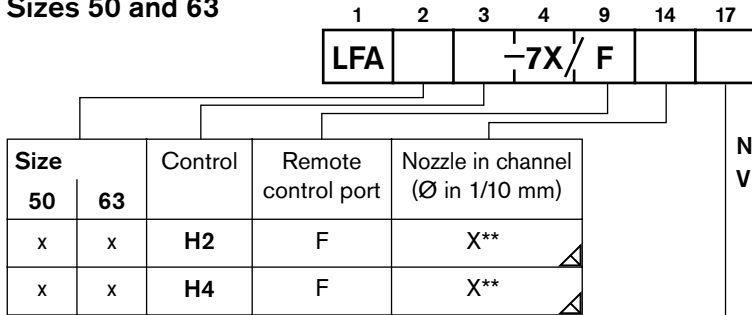

No code =
V =

NBR seals
FKM seals
(Other seals on enquiry)

⚠ Caution!

Observe compatibility of seals with hydraulic fluid used!

⚠ Nozzle possible; indicate, if required

Type LFA . H.../F

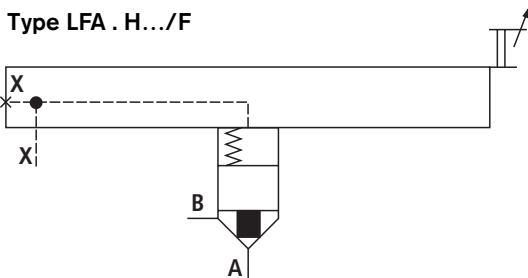

Type LFA . H.../FX**

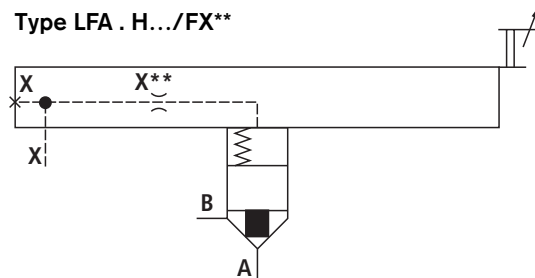

Control "H4"

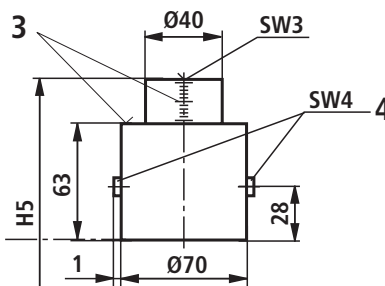

Control "H2"

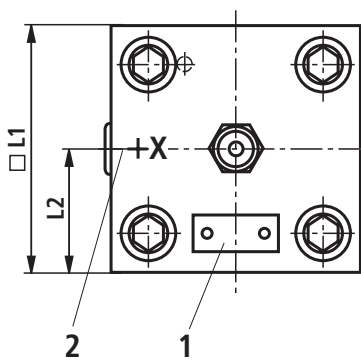
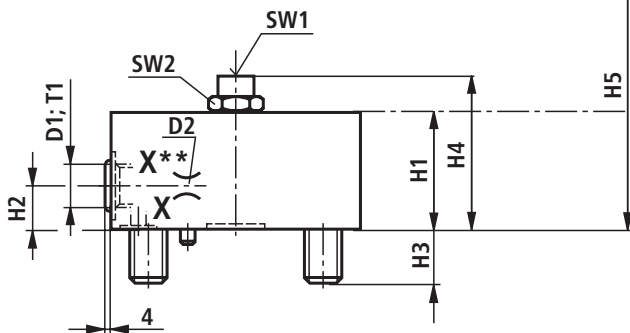

- 1 Nameplate
- 2 Port X optional as threaded connection
- 3 Scale
- 4 Secured by means of locknut

¹⁾ For ordering codes for nozzles, see page 14 and 15.

²⁾ Hexagonal socket

| Size | 50 | 63 |
|--------------------|--------|------|
| D1 | G1/2 | G3/4 |
| D2 ¹⁾ | M8 x 1 | G3/8 |
| H1 | 110 | 125 |
| H2 | 32 | 40 |
| H3 | 34 | 50 |
| H4 max | 156 | 175 |
| H5 max | 200 | 220 |
| □ L1 | 140 | 180 |
| L2 | 80 | 90 |
| T1 | 14 | 16 |
| A/F1 ²⁾ | 17 | 24 |
| A/F2 | 55 | 65 |
| A/F3 ²⁾ | 19 | 19 |
| A/F4 | 5 | 5 |

Control cover with stroke limiter and remote control port: Type ..H... (nominal dimensions in mm)

Sizes 80 to 160

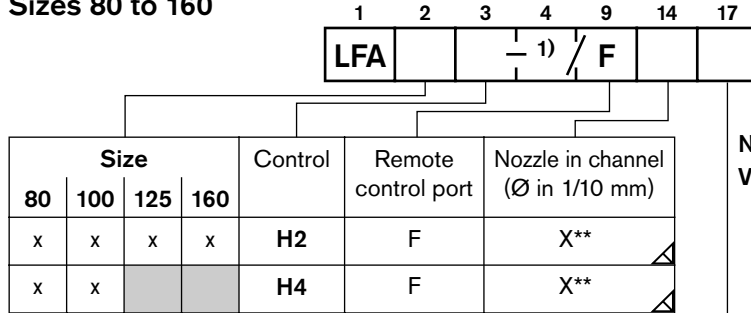

No code =
V =

NBR seals
FKM seals
(Other seals on enquiry)

⚠ Caution!
Observe compatibility of seals with hydraulic fluid used!

△ Nozzle possible; indicate, if required

1) 6X = series 6X (sizes 80, 100)
2X = series 2X (sizes 125, 160)

Type LFA . H.../F

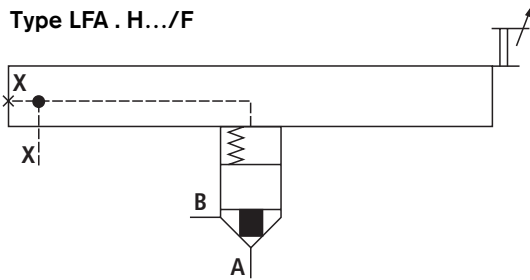

Control "H2" - sizes 80 to 125

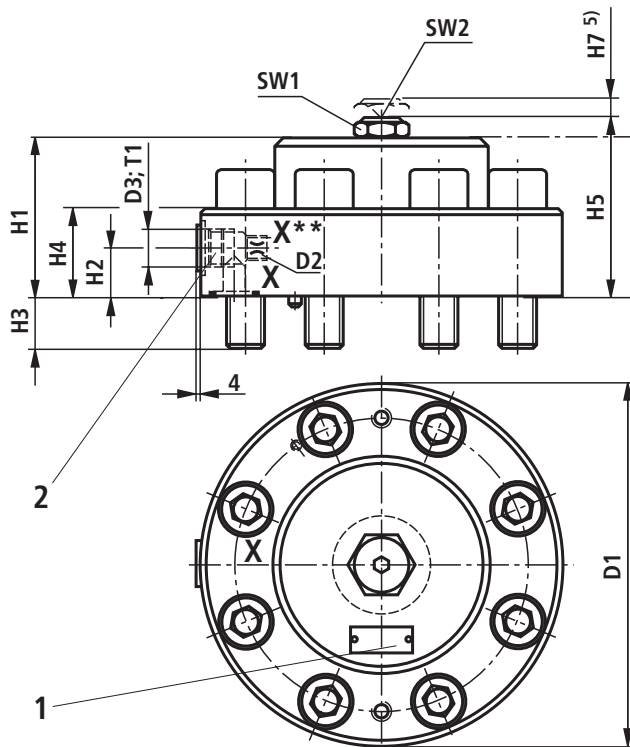

Type LFA . H.../FX**

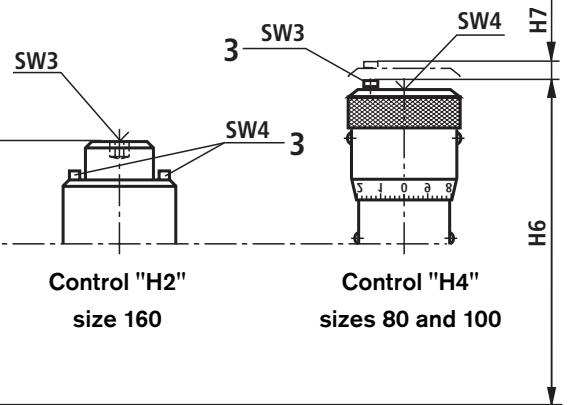
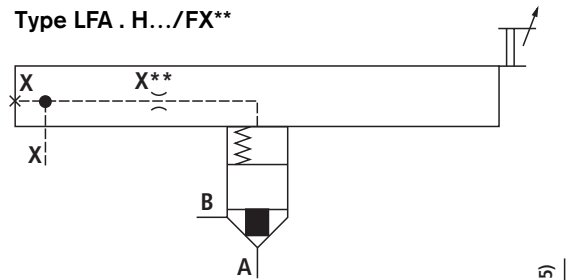

- 1 Nameplate
- 2 Port X optionally as threaded connection
- 3 Secured by means of locknut

- 2) For ordering codes for nozzles, see page 14 and 15.
- 3) Dimension () valid only for control "H4"
- 4) Hexagon socket
- 5) Maximum dimension

| Size | 80 | 100 | 125 | 160 |
|--------------------|------------------------|------|--------|--------|
| D1 | 250 | 300 | 380 | 480 |
| D2 | G3/8 | G1/2 | G1 | G1 |
| D3 ²⁾ | G3/4 | G1 | G1 1/4 | G1 1/4 |
| H1 | 114 | 132 | 170 | 225 |
| H2 | 35 (24 ³⁾) | 35 | 50 | 70 |
| H3 | 45 | 52.5 | 61 | 74 |
| H4 | 76 | 88.5 | 100 | 147 |
| H5 | 137 | 157 | 195 | 340 |
| H6 | 229 | 247 | - | - |
| H7 | 30 | 38 | 48 | - |
| T1 | 16 | 18 | 20 | 20 |
| A/F1 | 75 | 75 | 95 | - |
| A/F2 ⁴⁾ | 24 | 27 | 27 | - |
| A/F3 ⁴⁾ | - | - | - | 32 |
| A/F4 ⁴⁾ | - | - | - | 8 |
| A/F5 ⁴⁾ | 5 | 5 | - | - |
| A/F6 ⁴⁾ | 14 | 14 | - | - |

Control cover with integrated shuttle valve: Type ..G... (nominal dimensions in mm)

Sizes 16 to 63

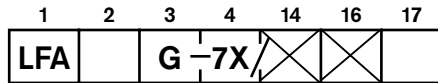

| Size | Nozzle in channel | |
|------|-------------------|------|
| | X | Z1 |
| 16 | Ø1,2 | Ø1,2 |
| 25 | Ø1,5 | Ø1,5 |
| 32 | Ø2,0 | Ø2,0 |
| 40 | X15 | Z15 |
| 50 | X18 | Z18 |
| 63 | X20 | Z20 |

No code = NBR seals
 V = FKM seals
 (Other seals on enquiry)
⚠ Caution!
 Observe compatibility of seals with hydraulic fluid used!

▲ Nozzle drilled (Ø in mm) ¹⁾
 ▽ Standard nozzle (Ø in 1/10 mm) ¹⁾

¹⁾ Not shown in the type designation

For ordering codes for nozzles, see page 14 and 15.

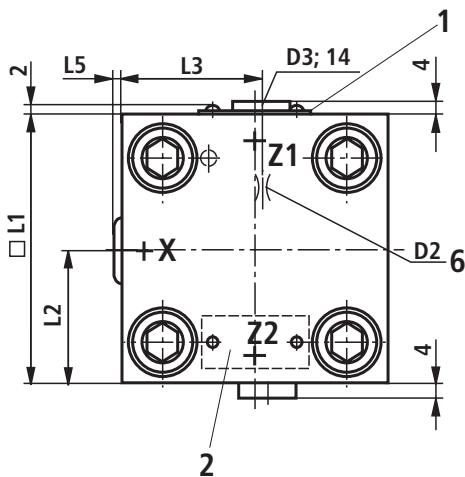
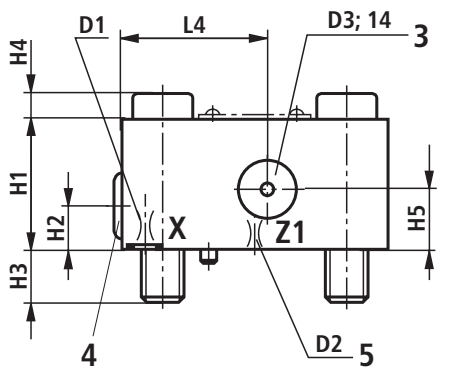
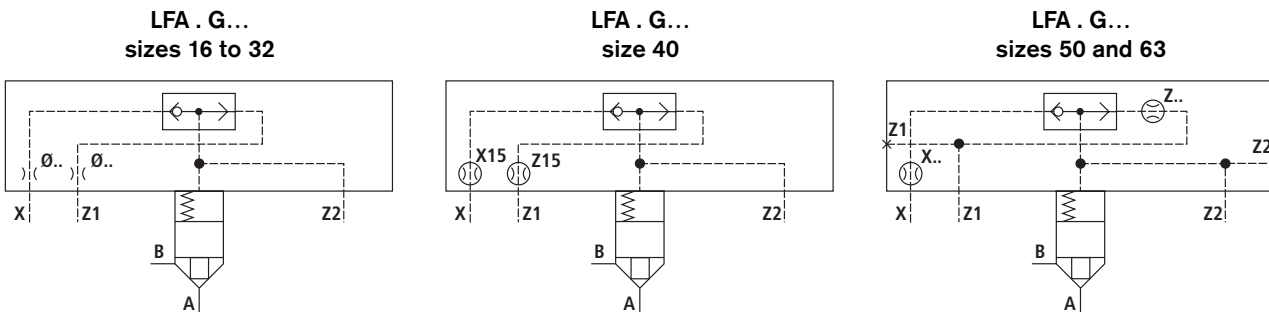

| Size | 16 | 25 | 32 | 40 | 50 | 63 |
|------|------|------|------|------|--------|--------|
| D1 | Ø1.2 | Ø1.5 | Ø2.0 | M6 | M8 x 1 | M8 x 1 |
| D2 | Ø1.2 | Ø1.5 | Ø2.0 | M6 | M8 x 1 | M8 x 1 |
| D3 | - | - | - | - | G1/2 | G1/2 |
| H1 | 35 | 30 | 35 | 60 | 68 | 82 |
| H2 | 17 | 17 | 21.5 | 30 | 32 | 42 |
| H3 | 15 | 24 | 28 | 32 | 34 | 50 |
| H4 | - | 12 | 16 | - | - | - |
| H5 | - | - | - | - | 32 | 40 |
| □ L1 | 65 | 85 | 100 | 125 | 140 | 180 |
| L2 | 36.5 | 45.5 | 50 | 62.5 | 74 | 90 |
| L3 | - | - | - | - | 72 | 81 |
| L4 | - | - | - | - | 72 | 90 |
| L5 | 4.5 | 4 | 1 | - | 6 | 4 |

- 1 Nameplate for sizes 16, 25, 32
- 2 Nameplate for sizes 40, 50, 63
- 3 Ports Z1 and Z2 optionally as threaded connection for sizes 50 and 63
- 4 Shuttle valve
- 5 D2 for sizes 16 to 40
- 6 D2 for sizes 50 and 63

Control cover with integrated shuttle valve: Type ..G... (nominal dimensions in mm)

Sizes 80 to 100

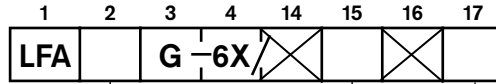

| Size | Nozzle in channel (Ø in 1/10 mm) | | |
|------|----------------------------------|-----|-----|
| | X | F | Z1 |
| 80 | X20 | F** | Z20 |
| 100 | X20 | F** | Z20 |

No code = NBR seals
 V = FKM seals
 (Other seals on enquiry)
⚠ Caution!
 Observe compatibility of seals with hydraulic fluid used!

- △ Standard nozzle – not shown in the type designation
- △ Nozzle possible; indicate, if required

For ordering codes for nozzles, see page 14 and 15.

LFA . G...

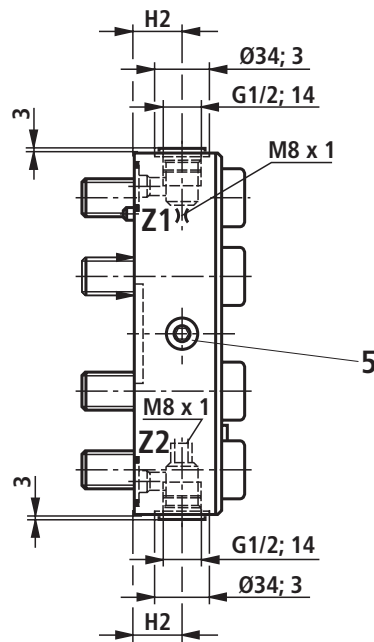
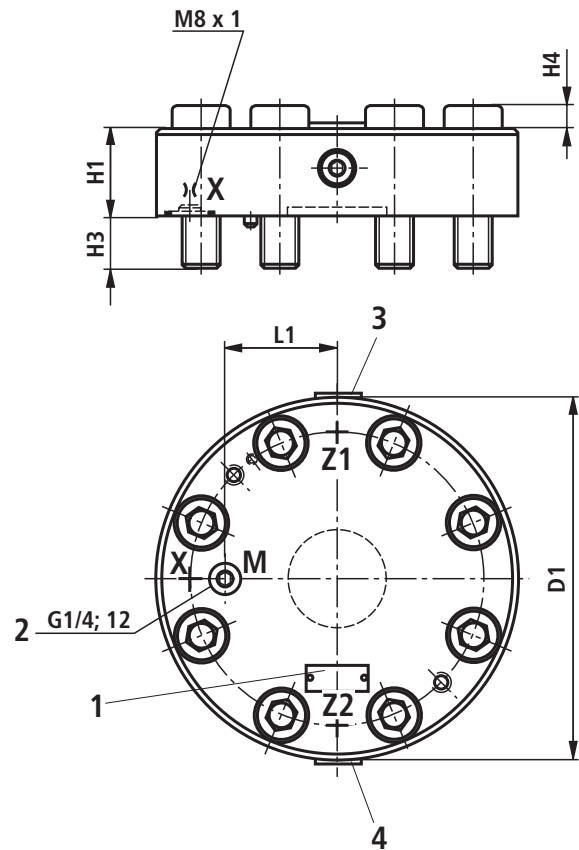
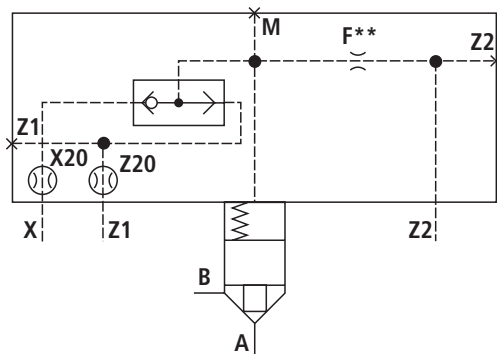

| Size | 80 | 100 |
|------|-----|------|
| D1 | 250 | 300 |
| H1 | 80 | 75 |
| H2 | 45 | 43 |
| H3 | 45 | 52,5 |
| H4 | 4 | 23,5 |
| L1 | 73 | 96,5 |

- 1 Nameplate
- 2 Measuring port
- 3 Port Z1 optionally as threaded connection
- 4 Port Z2 optionally as threaded connection
- 5 Shuttle valve

Control cover with integrated directional poppet valve: Type ..R...; ..RF...

Sizes 25 to 63

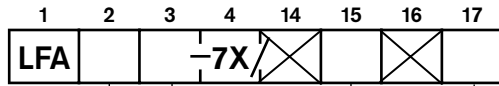

| Size | Type | Nozzle in channel (Ø in 1/10 mm) | | |
|------|------------------|-------------------------------------|-----|-----|
| | | X | F** | Z1 |
| 25 | R | X10 | F** | Z12 |
| 32 | R | X12 | F** | Z12 |
| 40 | R | X15 | F** | Z12 |
| 50 | R | X15 | F** | Z12 |
| 63 | R | X18 | F** | Z12 |
| 25 | RF ¹⁾ | X10 | F** | Z12 |
| 32 | RF ¹⁾ | X12 | F** | Z12 |
| 40 | RF ¹⁾ | X15 | F** | Z12 |
| 50 | RF ¹⁾ | X15 | F** | Z12 |
| 63 | RF ¹⁾ | X18 | F** | Z12 |

No code =
V =

NBR seals
FKM seals
(Other seals on enquiry)
⚠ Caution!
Observe compatibility of seals with hydraulic fluid used!

- △ Standard nozzle – not shown in the type designation
- △ Nozzle possible; indicate, if required

¹⁾ Directional poppet valve with spring return

**LFA . R...
sizes 25 to 50**

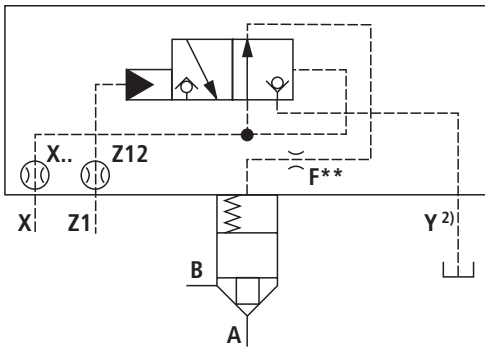

**LFA 63 R...
size 63**

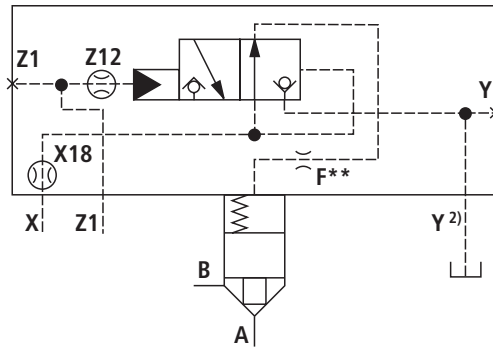

**LFA . RF...
sizes 25 to 50**

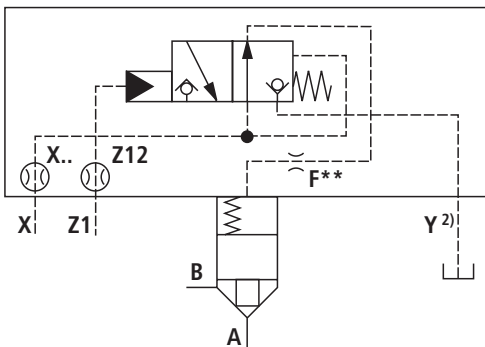

**LFA 63 RF...
size 63**

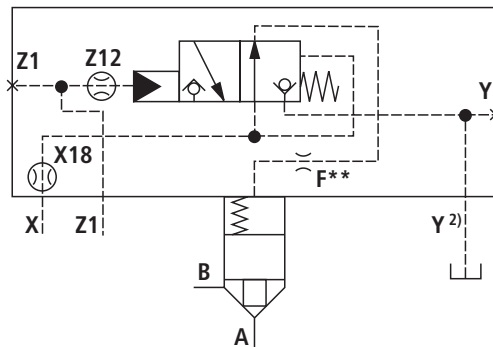

²⁾ Max. pressure in port Y 5 bar

Control cover with integrated directional poppet valve: Type ..R...; ..RF... (nominal dimensions in mm)

Sizes 25 to 63

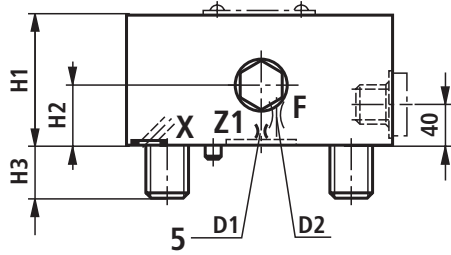

$$\text{Area ratio} \quad \frac{A_{Z1}}{A_X} = \frac{3}{1}$$

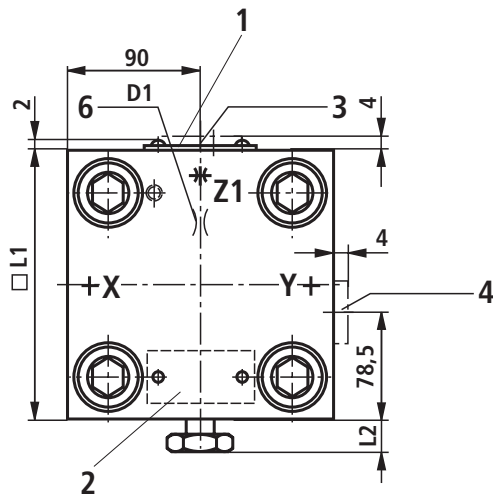

| Size | Type | 25 | 32 | 40 | 50 | 63 |
|------------------|------|------|------|--------|--------|--------|
| D1 ³⁾ | | M6 | M6 | M8 x 1 | M8 x 1 | M8 x 1 |
| D2 ³⁾ | | M6 | M6 | M8 x 1 | M8 x 1 | M8 x 1 |
| H1 | | 40 | 50 | 60 | 68 | 82 |
| H2 | | 20 | 26 | 33 | 32 | 40 |
| H3 | | 24 | 28 | 32 | 34 | 50 |
| □ L1 | | 85 | 100 | 125 | 140 | 180 |
| L2 | R | 2 | 1 | 4 | 3 | – |
| | RF | 18.5 | 17.5 | 25 | 24 | 16 |

³⁾ For ordering codes for nozzles, see page 14 and 15.

- 1 Nameplate for sizes 16, 25, 32
- 2 Nameplate for sizes 40, 50, 63
- 3 Port Z1 optionally as threaded connection for size 63 – G1/4; 12
- 4 Port Y optionally as threaded connection for size 63 – G1/2; 14
- 5 D1 for sizes 16 to 50
- 6 D1 for size 63

Control cover with integrated directional poppet valve: Type ..R...; ..R2...(nominal dimensions in mm)

Sizes 80 and 100

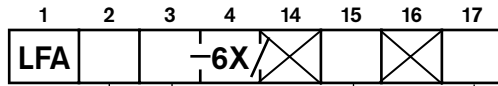

| Size | Type | Nozzle in channel (Ø in 1/10 mm) | | |
|------|------------------|-------------------------------------|-----|-----|
| | | X | F** | Z1 |
| 80 | R | X20 | F** | Z12 |
| 100 | R | X25 | F** | Z12 |
| 80 | R2 ¹⁾ | X20 | F** | Z12 |
| 100 | R2 ¹⁾ | X25 | F** | Z12 |

No code =
V =

NBR seals
FKM seals
(Other seals on enquiry)
⚠ Caution!
Observe compatibility of seals with hydraulic fluid used!

- △ Standard nozzle – not shown in the type designation
- △ Nozzle possible; indicate, if required

¹⁾ Directional poppet valve with spring return

LFA . R...

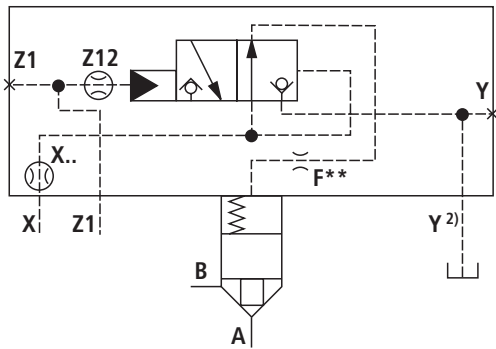

LFA . R2...

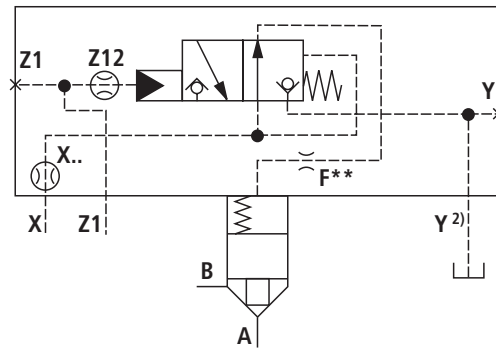

²⁾ Max. pressure in port Y 5 bar

Control cover with integrated directional poppet valve: Type ..R...; ..R2... (nominal dimensions in mm)
Sizes 80 and 100

Area ratio $\frac{A_{Z1}}{A_x} = \frac{3}{1}$

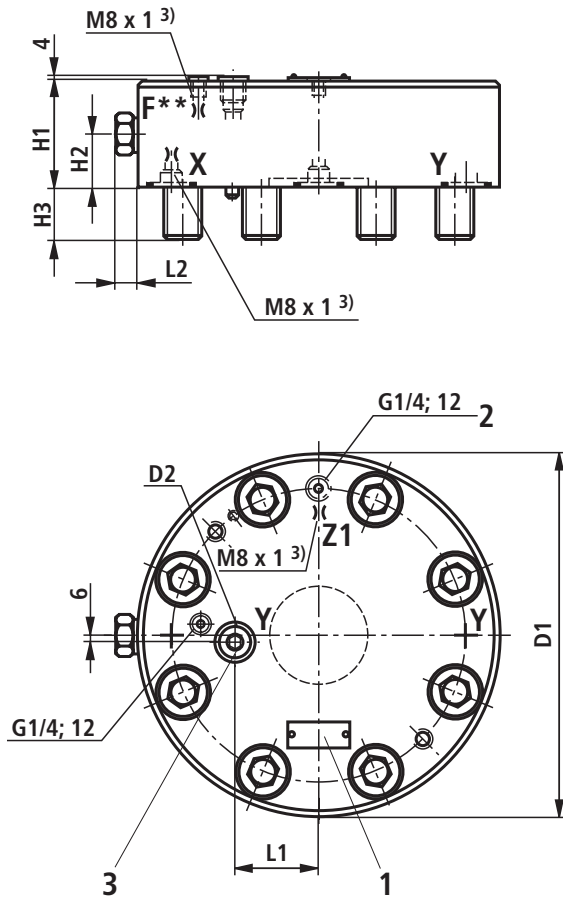

| Size | 80 | 100 |
|------|----------|----------|
| D1 | 250 | 300 |
| D2 | G1/4; 12 | G1/2; 14 |
| H1 | 80 | 100 |
| H2 | 36 | 45 |
| H3 | 45 | 52 |
| L1 | 52 | 74 |
| L2 | 21 | 18 |
| L3 | 6 | 5 |

³⁾ For ordering codes for nozzles, see page 14 and 15.

- 1 Nameplate
- 2 Port Z1 optionally as threaded connection
- 3 Port Y optionally as threaded connection

Control cover for mounting a directional spool or poppet valve: Type ..WEA..., ..WEB...

Sizes 16 to 50

| | | | | | | | | | | | | | |
|--|--|--|--|--|-----|---|---|------|----|----|----|----|----|
| | | | | | 1 | 2 | 3 | 4 | 10 | 11 | 12 | 13 | 17 |
| | | | | | LFA | | | -7X/ | | | | | |

| Size | | | | | Type | Nozzle in channel (Ø in 1/10 mm) | | | |
|------|----|----|----|----|------|-------------------------------------|-----|-----|-----|
| 16 | 25 | 32 | 40 | 50 | | A | B | P | T |
| x | x | x | x | x | WEA | A** | | P** | T** |
| x | x | x | x | x | WEB | | B** | P** | T** |

No code = NBR seals
 V = FKM seals
 (Other seals on enquiry)
⚠ Caution!
 Observe compatibility of seals with hydraulic fluid used!

⚠ Nozzle possible; indicate, if required

For ordering codes for nozzles, see page 14 and 15.

M-3SEW 6 C../420...

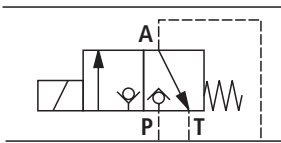

M-3SED 6 CK../350...

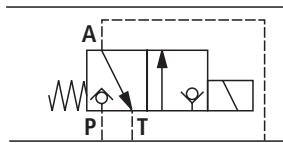

M-3SED 6 UK../350...
M-3SEW 6 U../420...

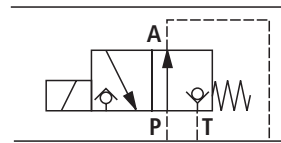

LFA . WEA...
sizes 16 to 32

(with directional spool valve type 4WE 6 D...)

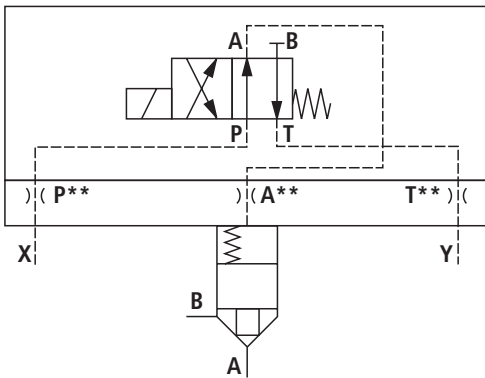

LFA . WEB...
sizes 16 to 32

(with directional spool valve type 4WE 6 D...)

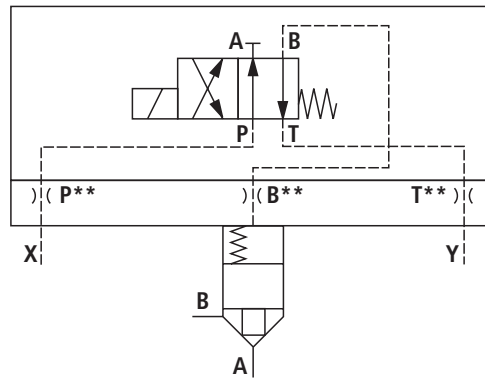

LFA . WEA...
sizes 40 and 50

(with directional spool valve type 4WE 6 D...)

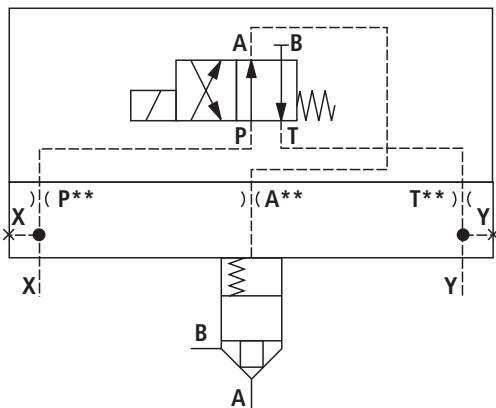

LFA . WEB...
sizes 40 and 50

(with directional spool valve type 4WE 6 D...)

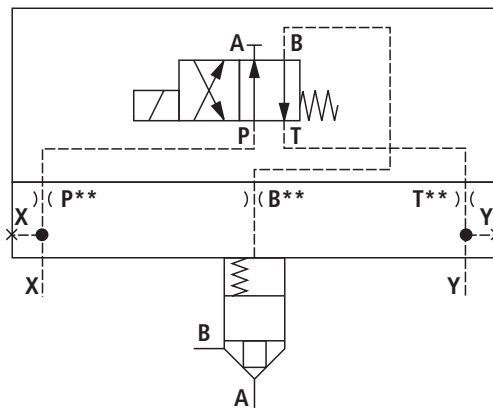

Control cover for mounting a directional spool or poppet valve: Type ..WEA..., ..WEB... (nominal dimensions in mm)

Sizes 16 to 50

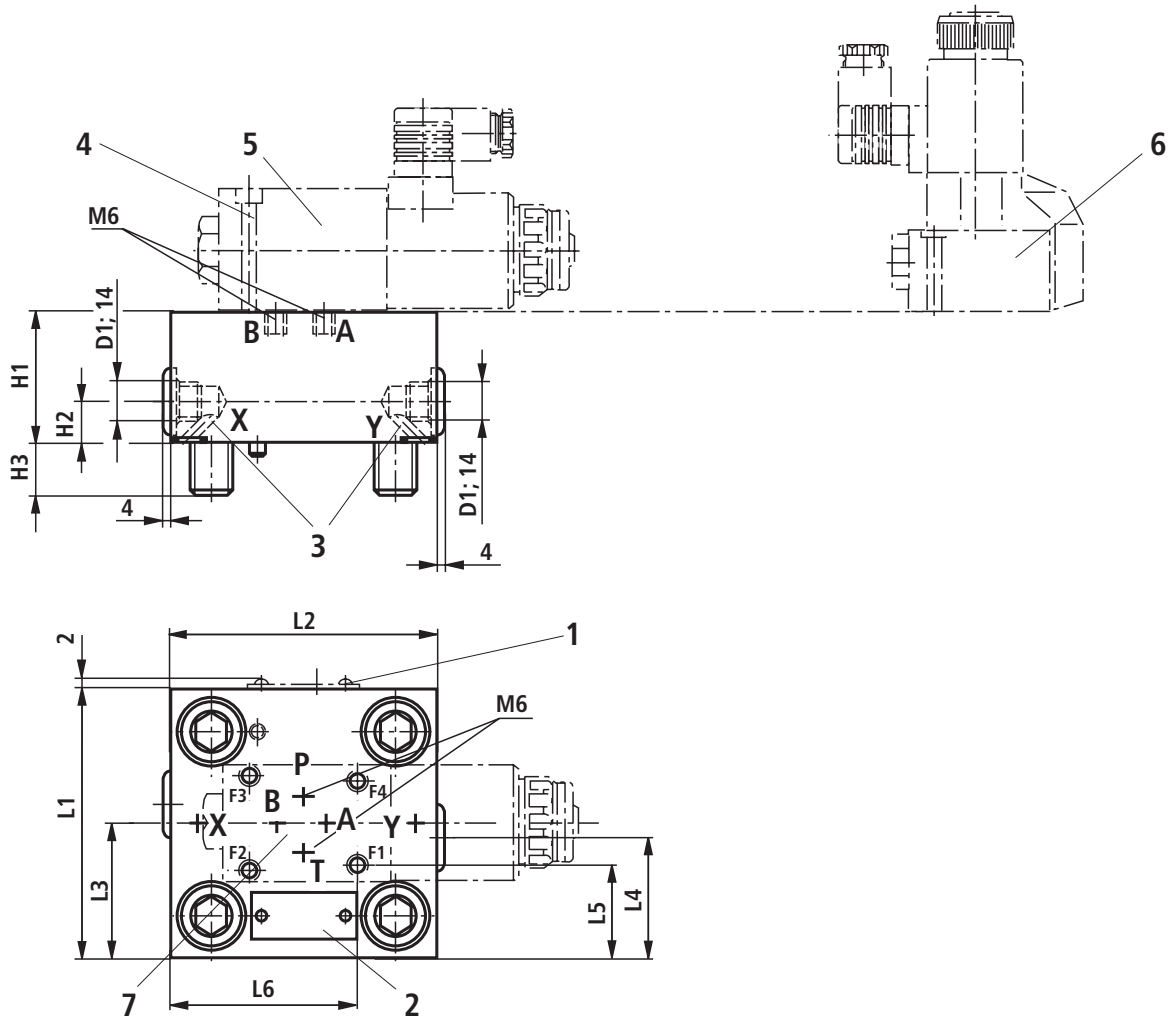

- 1 Nameplate for sizes 16, 25, 32
- 2 Nameplate for sizes 40 and 50
- 3 Ports X and Y optionally as threaded connection for sizes 40 and 50
- 4 Valve fixing screws included in the control cover's scope of supply
- 5 Directional spool valve type 4WE 6 D...
- 6 Directional poppet valve type M-3SEW 6 ...
- 7 Position of ports according to ISO 4401-03-02-0-94

| Size | 16 | 25 | 32 | 40 | 50 |
|------|------|----|------|------|------|
| D1 | - | - | - | G1/2 | G1/2 |
| H1 | 40 | 40 | 50 | 60 | 68 |
| H2 | - | - | - | 30 | 32 |
| H3 | 15 | 24 | 28 | 32 | 34 |
| L1 | 65 | 85 | 100 | 125 | 140 |
| L2 | 80 | 85 | 100 | 125 | 140 |
| L3 | - | - | - | 72 | 80 |
| L4 | - | - | - | 53 | 60 |
| L5 | 17 | 27 | 34.5 | 47 | 54.5 |
| L6 | 47.5 | 64 | 71.5 | 84 | 91.5 |

Control cover for mounting a directional spool or poppet valve: Type ..WEA..., ..WEB...

Size 63

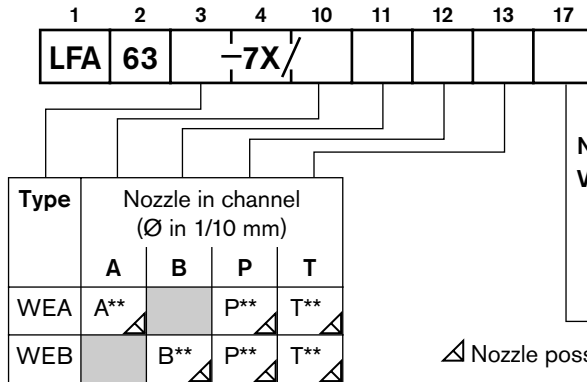

No code =
V =

NBR seals
FKM seals
(Other seals on enquiry)

⚠ Caution!

Observe compatibility of seals with hydraulic fluid used!

⚠ Nozzle possible; indicate, if required

For ordering codes for nozzles, see page 14 and 15.

M-3SEW 10 C../420...

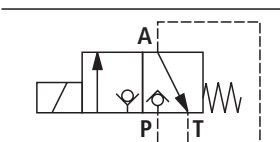

M-3SED 10 CK../350...

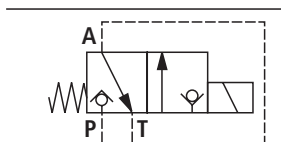

**M-3SED 10 UK../350...
M-3SEW 10 U../420...**

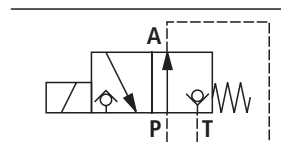

LFA 63 WEA...

(with directional spool valve type 4WE 10 D...)

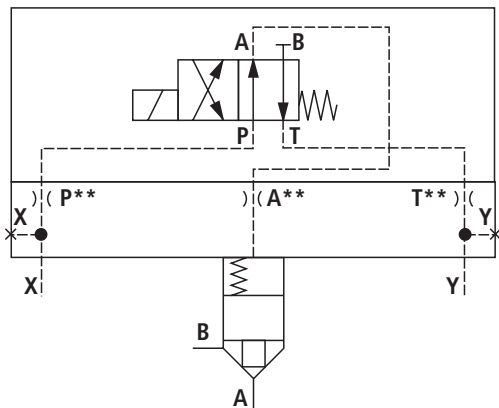

LFA 63 WEB...

(with directional spool valve type 4WE 10 D...)

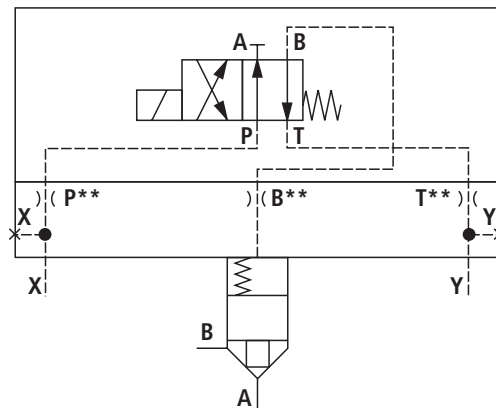

Control cover for mounting a directional spool or poppet valve: Type ..WEA..., ..WEB...

(nominal dimensions in mm)

Size 63

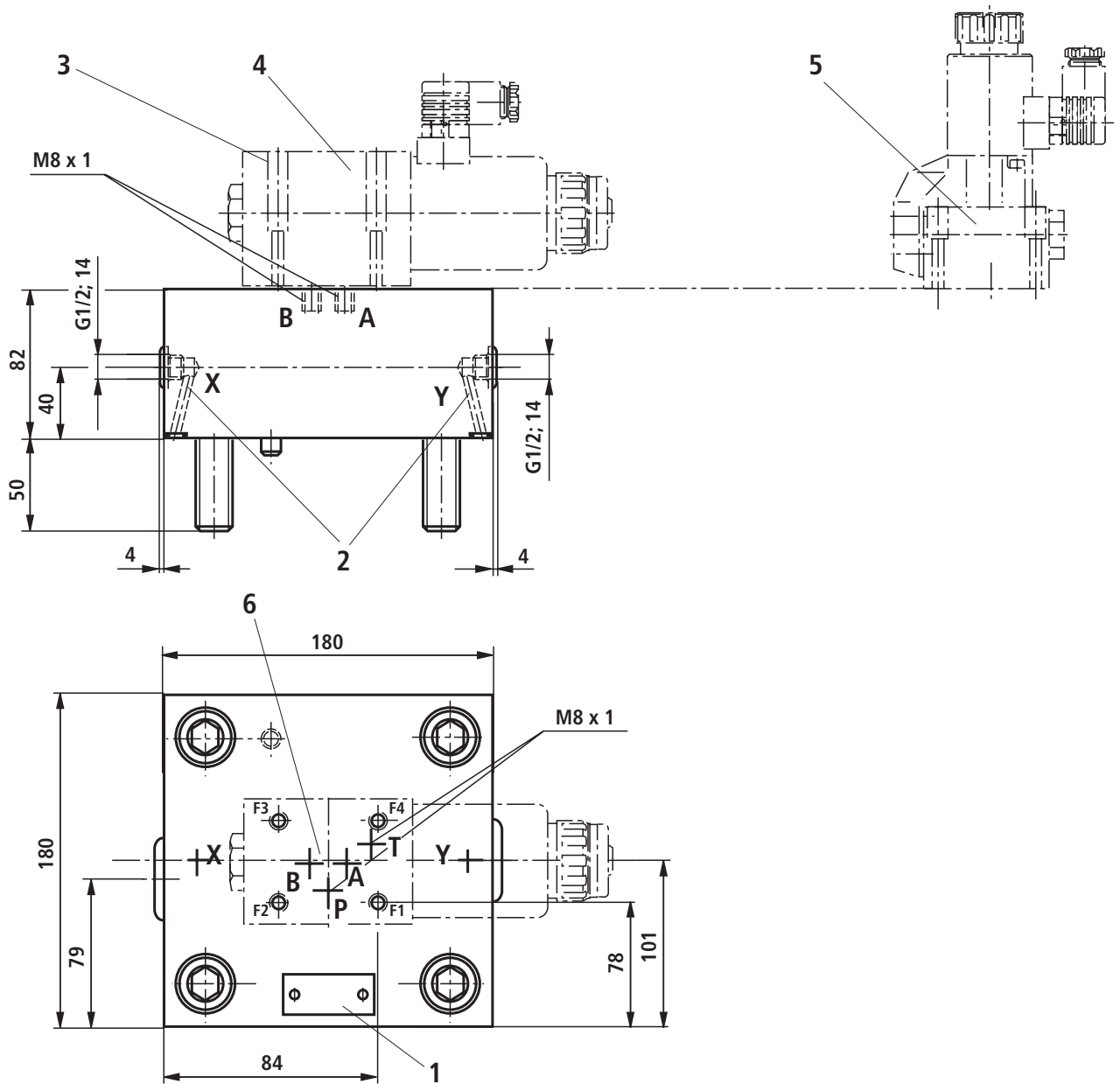

- 1 Nameplate
- 2 Ports X and Y optionally as threaded connection
- 3 Valve fixing screws are included in the control cover's scope of supply
- 4 Directional spool valve type 4WE 10 D...
- 5 Directional poppet valve type M-3SEW 10 ...
- 6 Position of ports to ISO 4401-05-04-0-94

Control cover for mounting a directional spool or poppet valve: Type ..WEA..., ..WEB...

Sizes 80 and 100

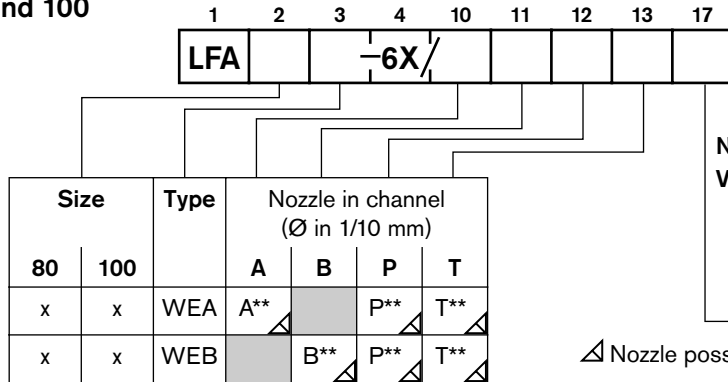

No code =
V =

NBR seals
FKM seals
(Other seals on enquiry)

⚠ Caution!

Observe compatibility of seals with hydraulic fluid used!

⚠ Nozzle possible; indicate, if required

For ordering codes for nozzles, see page 14 and 15.

M-3SEW 10 C../420...

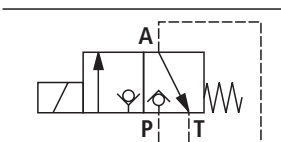

M-3SED 10 CK../350...

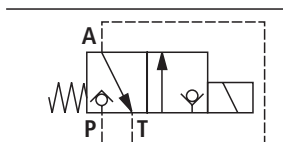

M-3SED 10 UK../350...
M-3SEW 10 U../420...

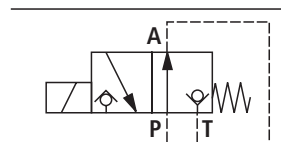

LFA . WEA...
sizes 80 and 100

(with directional spool valve type 4WE 10 D...)

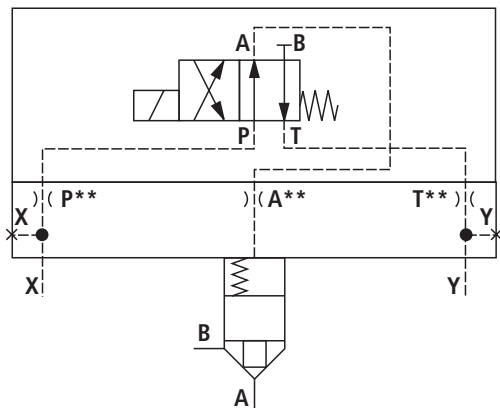

LFA . WEB...
sizes 80 and 100

(with directional spool valve type 4WE 10 D...)

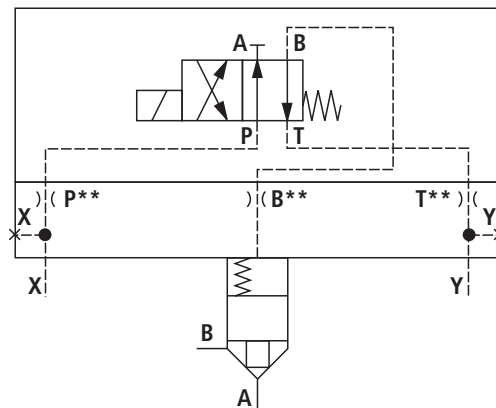

Control cover for mounting a directional spool or poppet valve: Type ..WEA..., ..WEB...

(nominal dimensions in mm)

Sizes 80 and 100

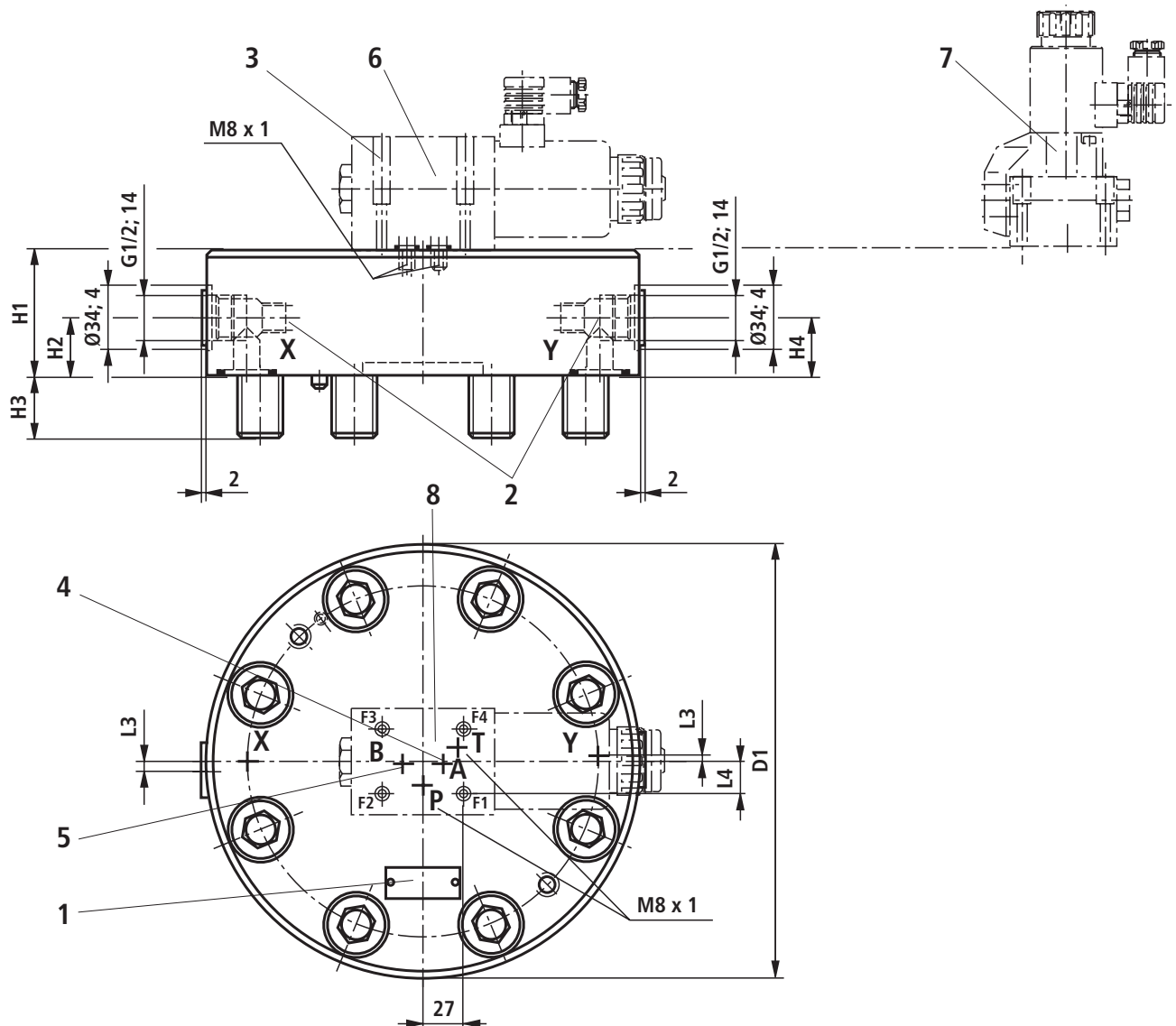

- 1 Nameplate
- 2 Ports X and Y optionally as threaded connection
- 3 Valve fixing screws are included in the control cover's scope of supply
- 4 Plug screw for type .. WEB..
- 5 Plug screw for type .. WEA..
- 6 Directional spool valve type 4WE 10 D...
- 7 Directional poppet valve type M-3SEW 10 ...
- 8 Position of ports to ISO 4401-05-04-0-94

| Size | 80 | 100 |
|------|-----|------|
| D1 | 250 | 300 |
| H1 | 80 | 100 |
| H2 | 30 | 24 |
| H3 | 45 | 52.5 |
| H4 | 45 | 55 |
| L3 | 10 | 13 |
| L4 | 16 | 18 |

Control cover for mounting a directional spool or poppet valve: Type ..WEMA..., ..WEMB...

Sizes 16 to 50

| | | | | | 1 | 2 | 3 | 4 | 12 | 13 | 15 | 17 |
|------|----|----|----|----|------|-------------------------------------|-----|------|----|----|----|----|
| | | | | | LFA | | | -7X/ | | | | |
| Size | | | | | Type | Nozzle in channel (Ø in 1/10 mm) | | | | | | |
| 16 | 25 | 32 | 40 | 50 | | P | T | F | | | | |
| x | x | x | x | x | WEMA | P** | T** | F** | | | | |
| x | x | x | x | x | WEMB | P** | T** | F** | | | | |

No code =
V =

NBR seals
FKM seals
(Other seals on enquiry)

⚠ Caution!

Observe compatibility of seals with hydraulic fluid used!

⚠ Nozzle possible; indicate, if required

For ordering codes for nozzles, see page 14 and 15.

M-3SEW 6 C../420...

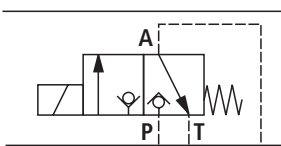

M-3SED 6 CK../350...

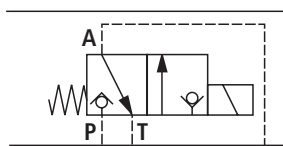

**M-3SED 6 UK../350...
M-3SEW 6 U../420...**

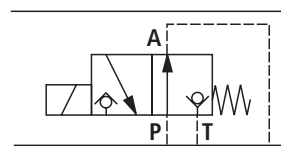

**LFA . WEMA...
sizes 16 to 32**

(with directional spool valve type 4WE 6 D...)

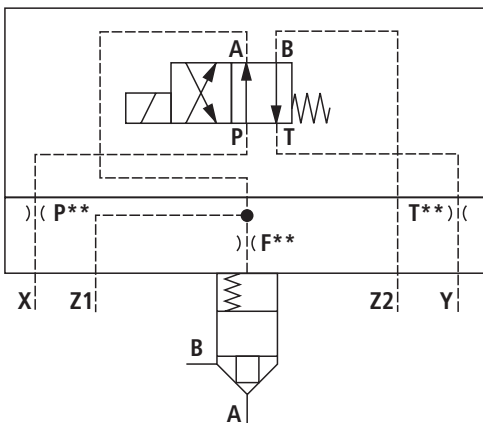

**LFA . WEMB...
sizes 16 to 32**

(with directional spool valve type 4WE 6 D...)

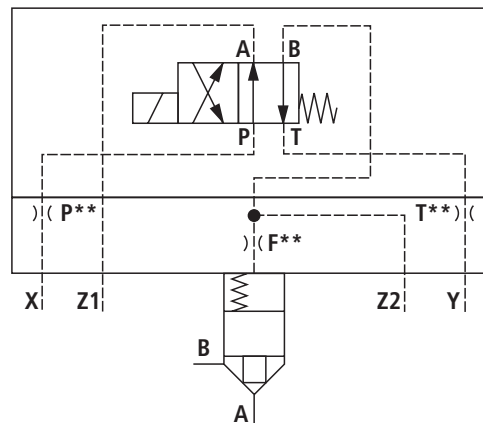

**LFA . WEMA...
sizes 40 and 50**

(with directional spool valve type 4WE 6 D...)

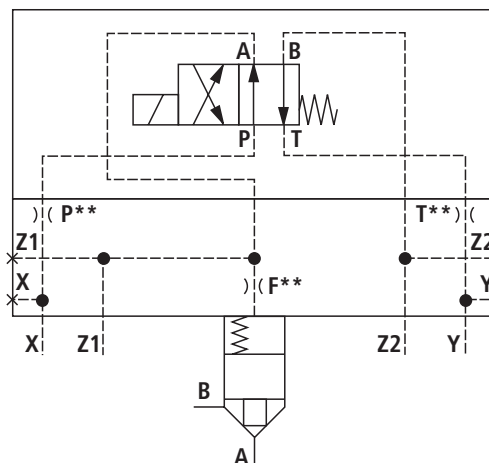

**LFA . WEMB...
sizes 40 and 50**

(with directional spool valve type 4WE 6 D...)

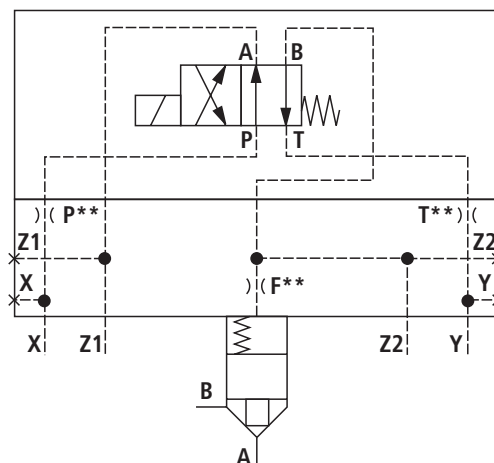

Control cover for mounting a directional spool or poppet valve: Type ..WEMA..., ..WEMB...
 (nominal dimensions in mm)

Sizes 16 to 50

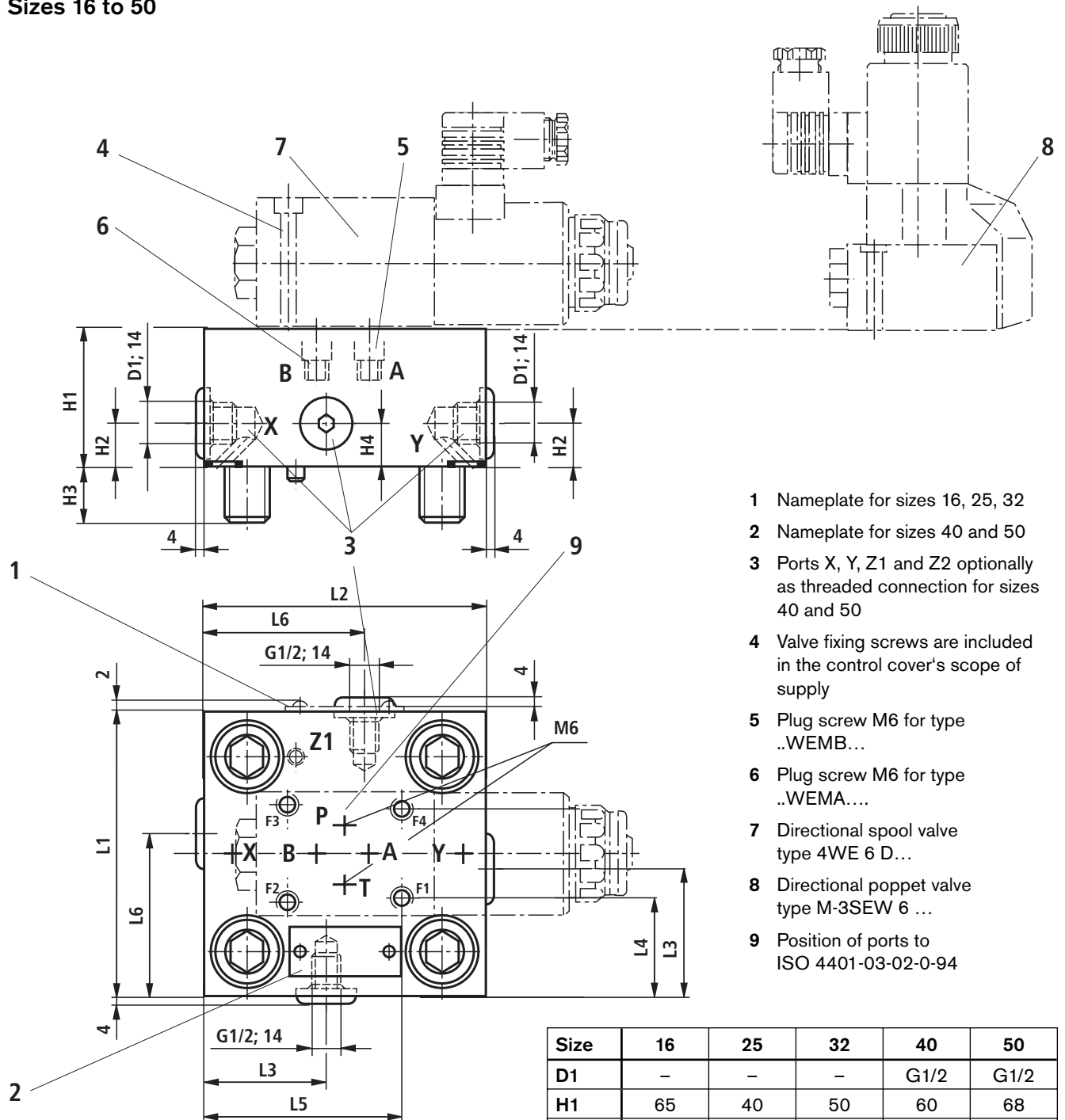

- 1 Nameplate for sizes 16, 25, 32
- 2 Nameplate for sizes 40 and 50
- 3 Ports X, Y, Z1 and Z2 optionally as threaded connection for sizes 40 and 50
- 4 Valve fixing screws are included in the control cover's scope of supply
- 5 Plug screw M6 for type ..WEMB...
- 6 Plug screw M6 for type ..WEMA....
- 7 Directional spool valve type 4WE 6 D...
- 8 Directional poppet valve type M-3SEW 6 ...
- 9 Position of ports to ISO 4401-03-02-0-94

| Size | 16 | 25 | 32 | 40 | 50 |
|------|------|----|------|------|------|
| D1 | - | - | - | G1/2 | G1/2 |
| H1 | 65 | 40 | 50 | 60 | 68 |
| H2 | - | - | - | 30 | 32 |
| H3 | 15 | 24 | 28 | 32 | 34 |
| H4 | - | - | - | 30 | 32 |
| L1 | 65 | 85 | 100 | 125 | 140 |
| L2 | 80 | 85 | 100 | 125 | 140 |
| L3 | - | - | - | 53 | 60 |
| L4 | 17 | 27 | 34.5 | 47 | 54.5 |
| L5 | 47.5 | 64 | 71.5 | 84 | 91.5 |
| L6 | - | - | - | 72 | 80 |

Control cover for mounting a directional spool or poppet valve: Type ..WEMA..., ..WEMB...

Size 63

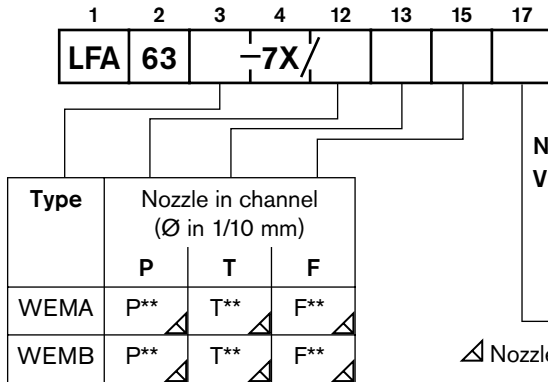

No code =
V =

NBR seals
FKM seals
(Other seals on enquiry)

⚠ Caution!

Observe compatibility of seals with hydraulic fluid used!

⚠ Nozzle possible; indicate, if required

For ordering codes for nozzles, see page 14 and 15.

M-3SEW 10 C../420...

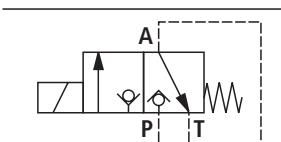

M-3SED 10 CK../350...

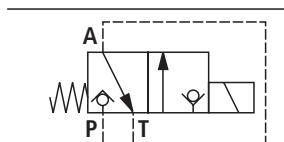

**M-3SED 10 UK../350...
M-3SEW 10 U../420...**

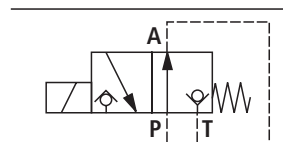

LFA 63 WEMA...

(with directional spool valve type 4WE 10 D...)

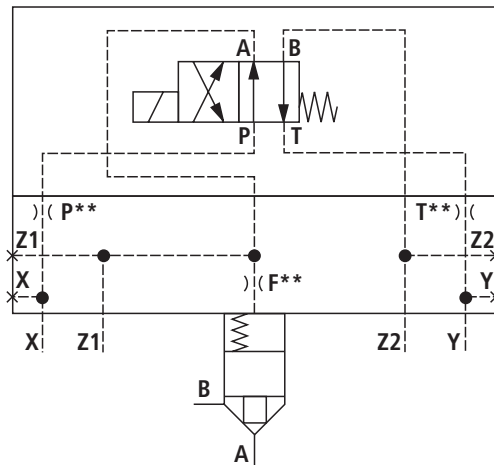

LFA 63 WEMB...

(with directional spool valve type 4WE 10 D...)

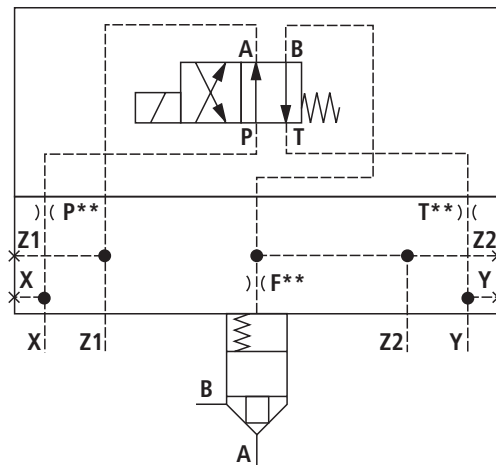

Control cover for mounting a directional spool or poppet valve: Type ..WEMA..., ..WEMB... (nominal dimensions in mm)

Size 63

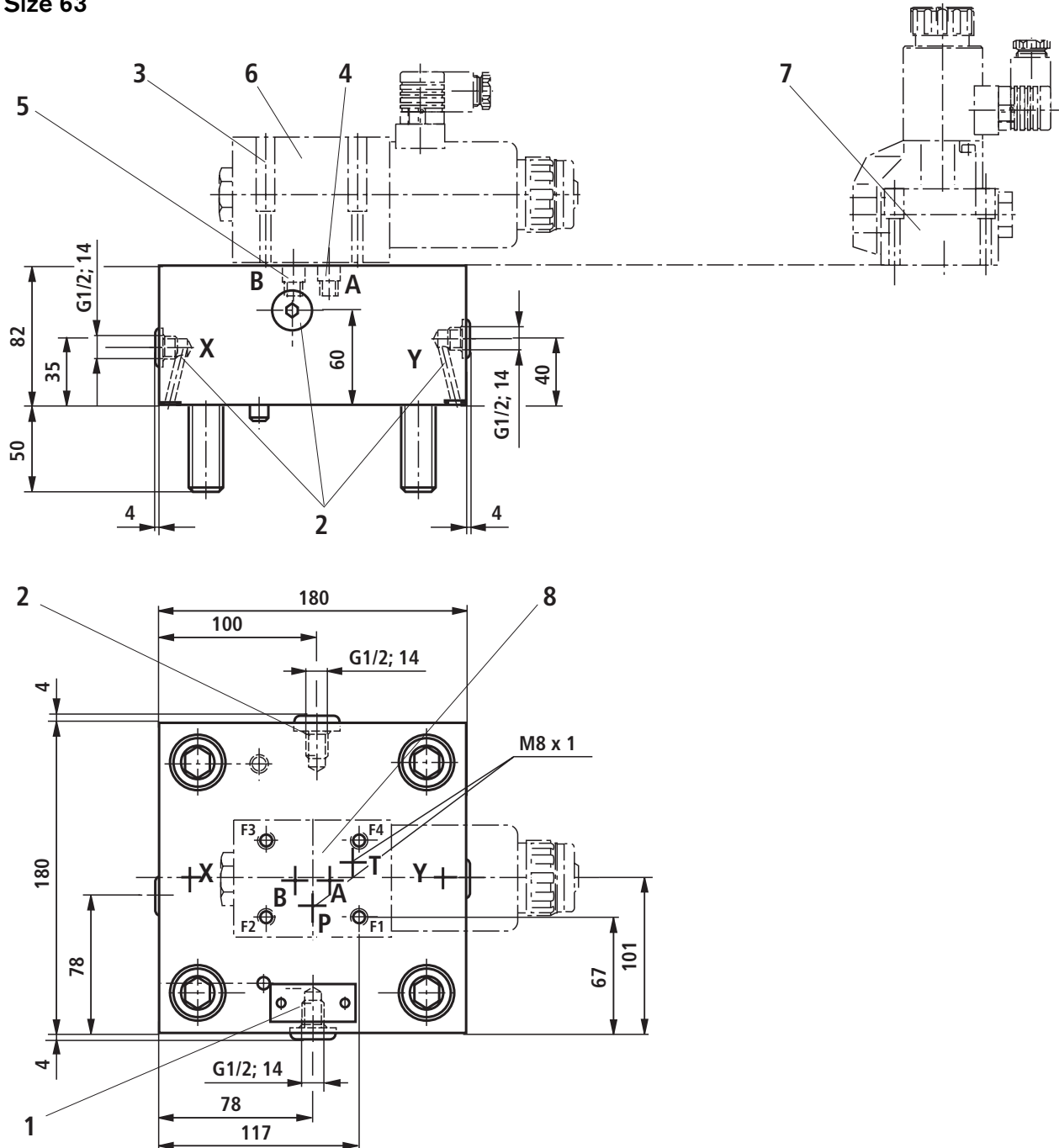

- 1 Nameplate
- 2 Ports X, Y, Z1 and Z2 optionally as threaded connection
- 3 Valve fixing screws are included in the control cover's scope of supply
- 4 Plug screw M8 x 1 for type ..WEMB...

- 5 Plug screw M8 x 1 for type ..WEMA...
- 6 Directional spool valve type 4WE 10 D...
- 7 Directional poppet valve type M-3SEW 10 ...
- 8 Position of ports to ISO 4401-05-04-0-94

Control cover for mounting a directional spool or poppet valve: Type ..WEA8..., ..WEB8...

Sizes 80 and 100

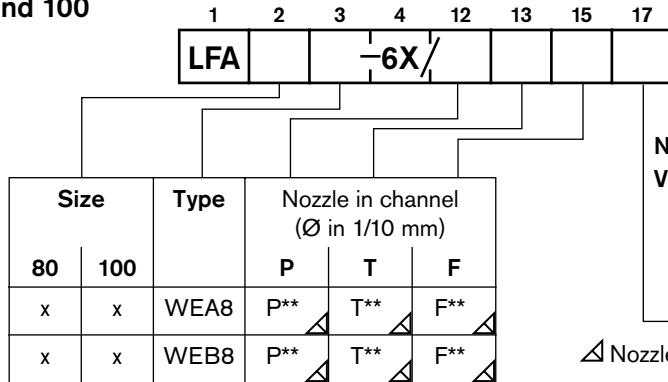

No code =
V =

NBR seals
FKM seals
(Other seals on enquiry)

⚠ Caution!

Observe compatibility of seals with hydraulic fluid used!

⚠ Nozzle possible; indicate, if required

For ordering codes for nozzles, see page 14 and 15.

M-3SEW 10 C../420...

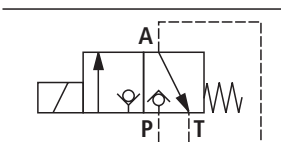

M-3SED 10 CK../350...

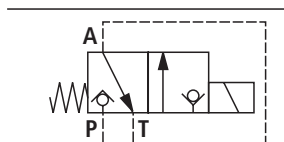

**M-3SED 10 UK../350...
M-3SEW 10 U../420...**

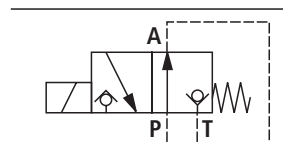

**LFA . WEA8...
sizes 80 and 100**

(with directional spool valve type 4WE 10 D...)

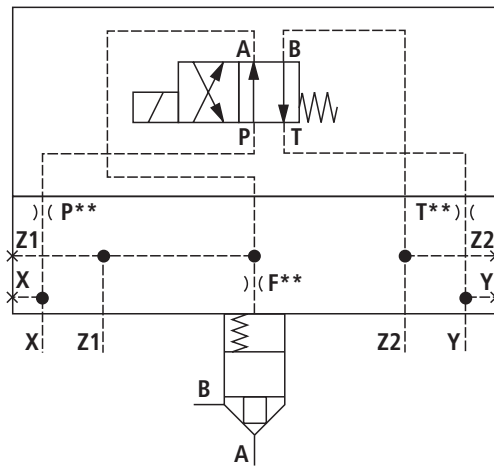

**LFA . WEB8...
sizes 80 and 100**

(with directional spool valve type 4WE 10 D...)

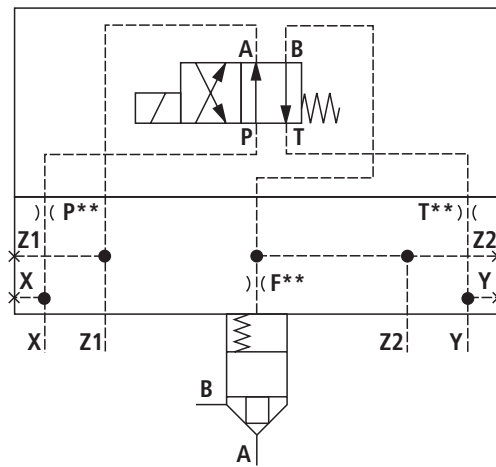

Control cover for mounting a directional spool or poppet valve: Type ..WEA8..., ..WEB8... (nominal dimensions in mm)

Sizes 80 and 100

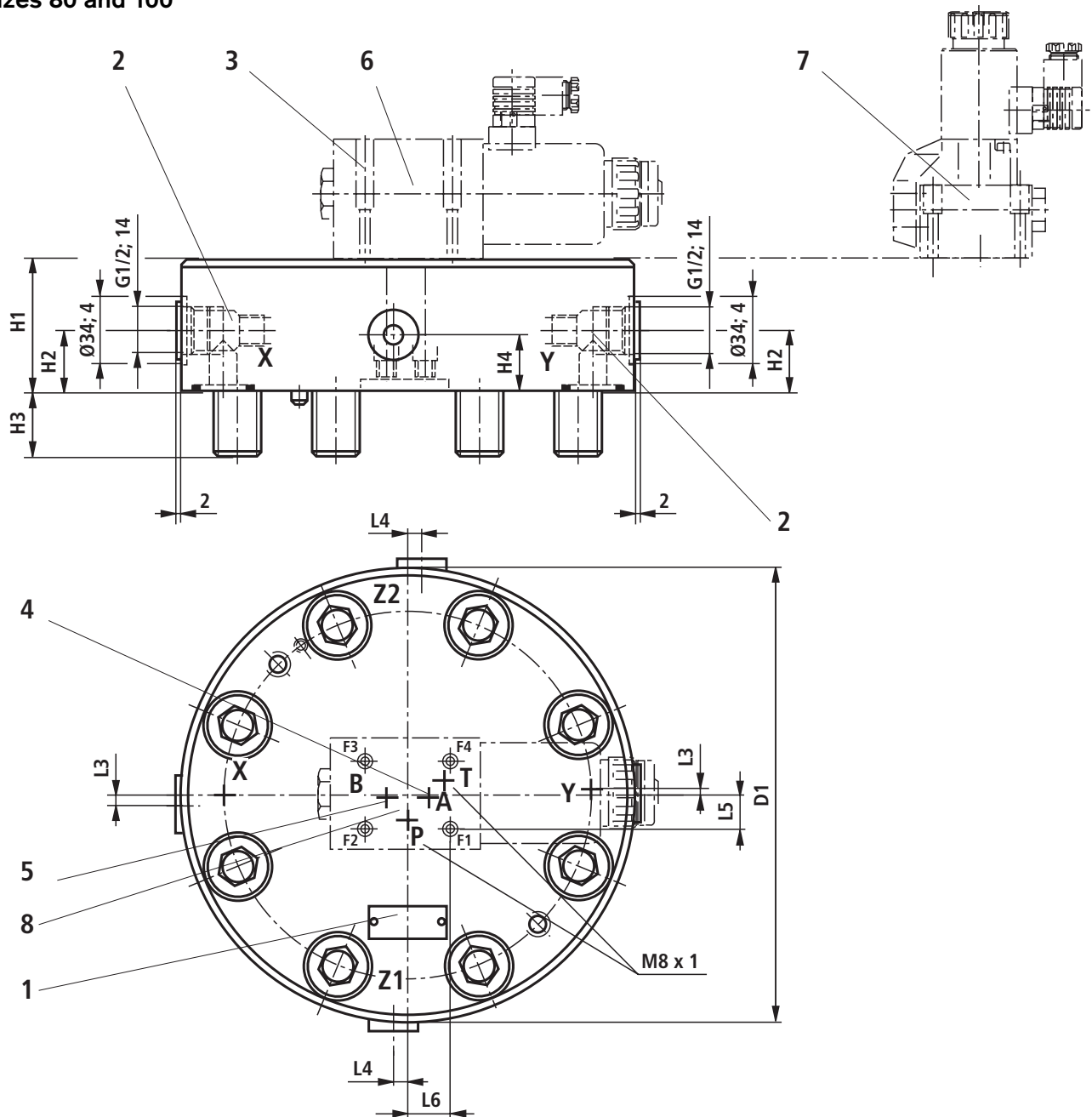

- 1 Nameplate
- 2 Ports X, Y, Z1 and Z2 optionally as threaded connection
- 3 Valve fixing screws are included in the control cover's scope of supply
- 4 Plug screw M8 x 1 for type .. WEB8..
- 5 Plug screw M8 x 1 for type .. WEA8..
- 6 Directional spool valve type 4WE 10 D...
- 7 Directional poppet valve type M-3SEW 10 ...
- 8 Position of ports to ISO 4401-05-04-0-94

| Size | 80 | 100 |
|------|-----|------|
| D1 | 250 | 300 |
| H1 | 80 | 100 |
| H2 | 42 | 55 |
| H3 | 45 | 52.5 |
| H4 | 26 | 35 |
| L3 | 10 | 13 |
| L4 | 10 | 9.5 |
| L5 | 16 | 27 |
| L6 | 27 | 26 |

Control cover for mounting a directional spool valve: Type ..WECA...

Sizes 16 to 50

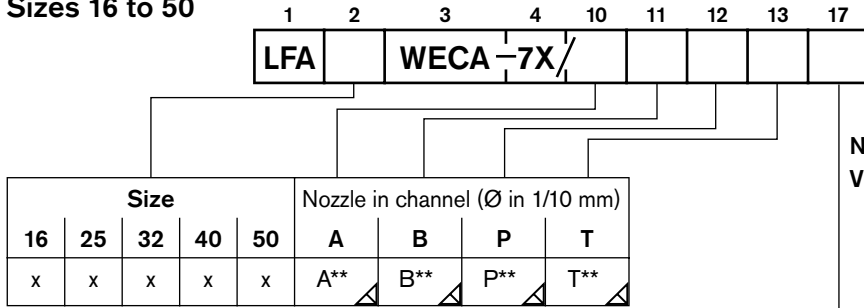

No code =
V =

NBR seals
FKM seals
(Other seals on enquiry)

⚠ Caution!

Observe compatibility of seals with hydraulic fluid used!

⚠ Nozzle possible; indicate, if required

For ordering codes for nozzles, see page 14 and 15.

LFA . WECA...
size 16

(with directional spool valve type 3WE 6 A...)

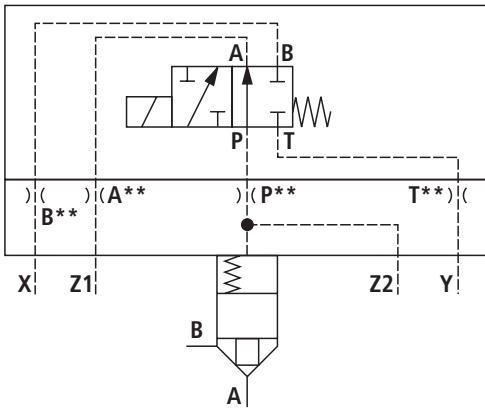

LFA . WECA...
sizes 25 and 32

(with directional spool valve type 3WE 6 A...)

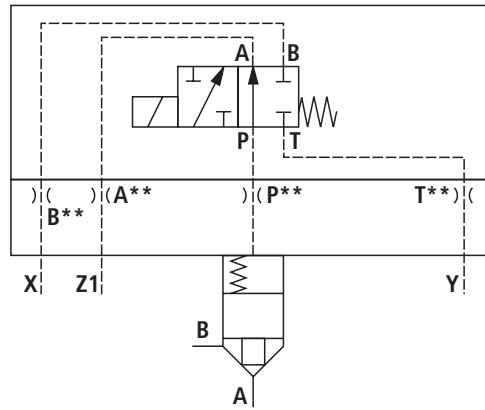

LFA . WECA...
sizes 40 and 50

(with directional spool valve type 3WE 6 A...)

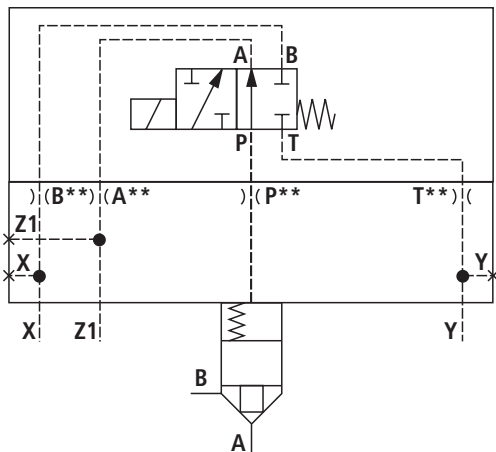

Control cover for mounting a directional spool valve: Type ..WECA... (nominal dimensions in mm)

Sizes 16 to 50

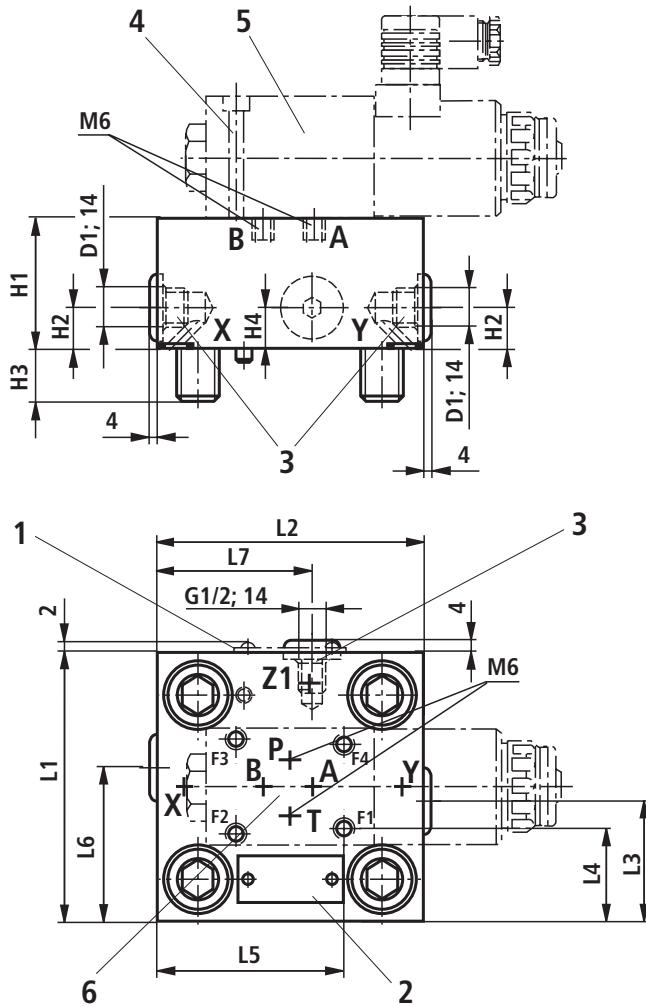

| Size | 16 | 25 | 32 | 40 | 50 |
|------|------|----|------|------|------|
| D1 | - | - | - | G1/2 | G1/2 |
| H1 | 40 | 40 | 50 | 60 | 68 |
| H2 | - | - | - | 30 | 32 |
| H3 | 15 | 24 | 28 | 32 | 34 |
| H4 | - | - | - | 30 | 32 |
| L1 | 65 | 85 | 100 | 125 | 140 |
| L2 | 80 | 85 | 100 | 125 | 140 |
| L3 | - | - | - | 53 | 60 |
| L4 | 17 | 27 | 34.5 | 47 | 54.5 |
| L5 | 47.5 | 64 | 71.5 | 84 | 91.5 |
| L6 | - | - | - | 62.5 | 70 |
| L7 | - | - | - | 72 | 80 |

- 1 Nameplate for sizes 16, 25, 32
- 2 Nameplate for sizes 40 and 50
- 3 Ports X, Y and Z1 optionally as threaded connection for sizes 40 and 50
- 4 Valve fixing screws are included in the control cover's scope of supply
- 5 Directional spool valve type 3WE 6 A...
- 6 Position of ports to ISO 4401-03-02-0-94

Control cover for mounting a directional spool valve: Type ..WECA... (nominal dimensions in mm)

Size 63

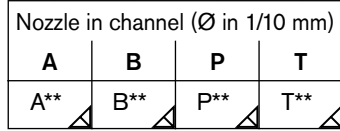
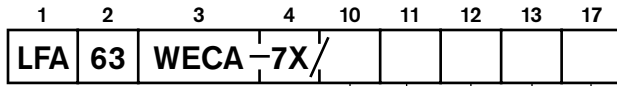

No code =
V =

NBR seals
FKM seals
(Other seals on enquiry)

⚠ Caution!

Observe compatibility of seals with hydraulic fluid used!

⚠ Nozzle possible; indicate, if required

For ordering codes for nozzles, see page 14 and 15.

LFA 63 WECA...

(with directional spool valve type 3WE 10 A...)

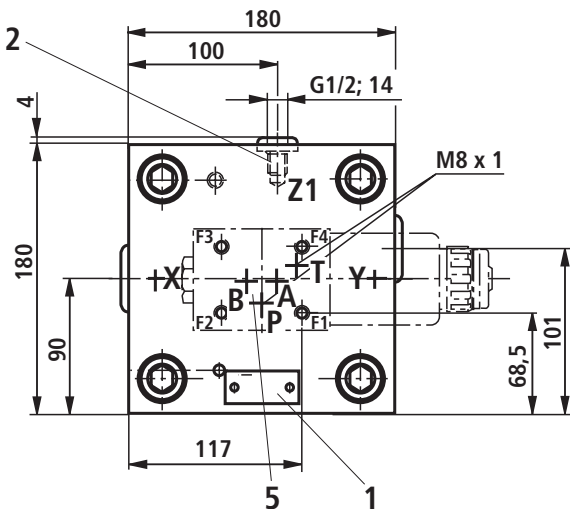
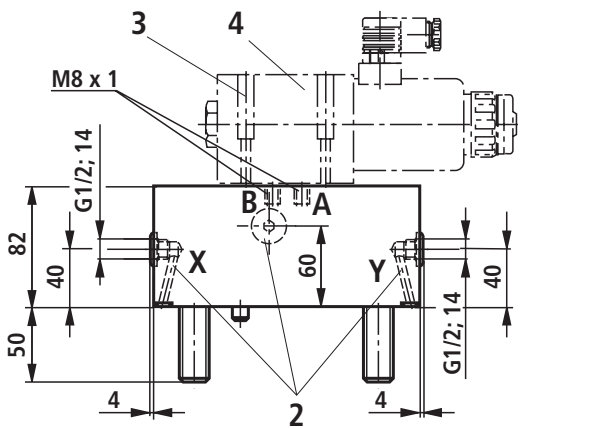
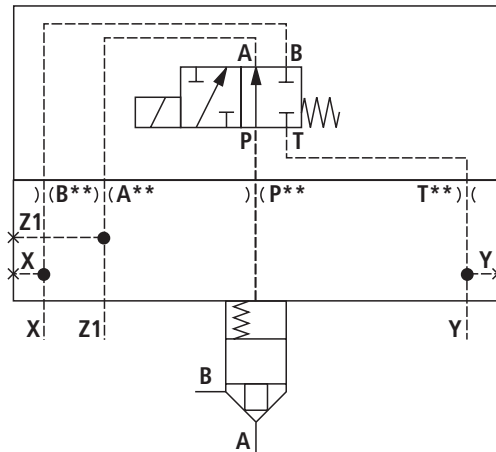

- 1 Nameplate
- 2 Ports X, Y and Z1 optionally as threaded connection
- 3 Valve fixing screws are included in the control cover's scope of supply
- 4 Directional spool valve type 3WE 6 A...
- 5 Position of ports to ISO 4401-05-04-0-94

Control cover for mounting a directional spool valve: Type ..WEA9... (nominal dimensions in mm)

Sizes 80 and 100

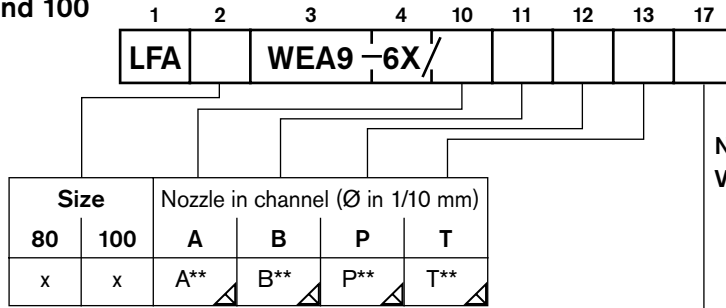

No code = NBR seals
 V = FKM seals
 (Other seals on enquiry)
⚠ Caution!
 Observe compatibility of seals with hydraulic fluid used!

▽ Nozzle possible; indicate, if required

For ordering codes for nozzles, see page 14 and 15.

**LFA . WEA9...
 sizes 80 and 100**
 (with directional spool valve type 3WE 10 A...)

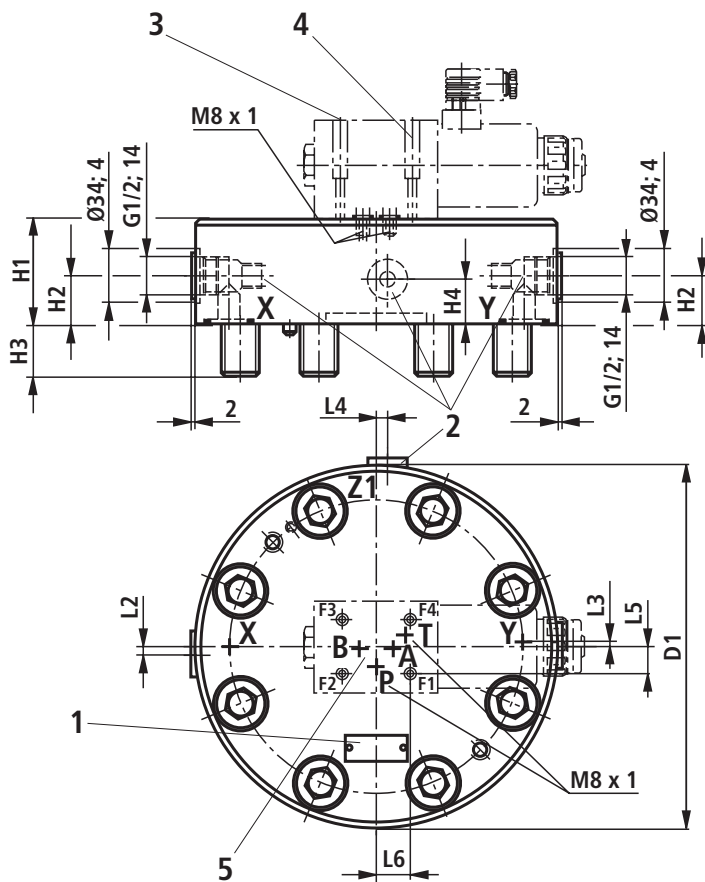
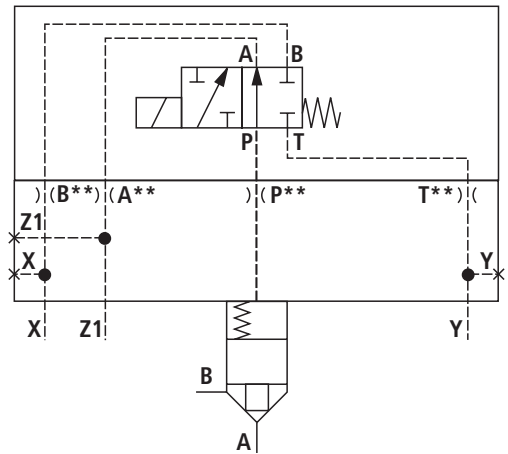

| Size | 80 | 100 |
|------|-----|------|
| D1 | 250 | 300 |
| H1 | 80 | 100 |
| H2 | 30 | 40 |
| H3 | 45 | 52.5 |
| H4 | 30 | 70 |
| L2 | 0 | 6 |
| L3 | 6 | 6 |
| L4 | 6 | 6 |
| L5 | 23 | 19 |
| L6 | 27 | 26 |

- 1 Nameplate
- 2 Ports X, Y, Z1 and Z2 optionally as threaded connection
- 3 Valve fixing screws included in the control cover's scope of supply
- 4 Directional spool valve type 3WE 10 A...
- 5 Position of ports to ISO 4401-05-04-0-94

Control cover for mounting a directional spool valve: Type ..GWA..., ..GWB...

Sizes 16 to 50

| | | | | | | | | | | | | | |
|--|--|--|--|--|-----|---|---|------|----|----|----|----|----|
| | | | | | 1 | 2 | 3 | 4 | 10 | 11 | 12 | 13 | 17 |
| | | | | | LFA | | | -7X/ | | | | | |

| Size | | | | | Type | Nozzle in channel (Ø in 1/10 mm) | | | |
|------|----|----|----|----|------|-------------------------------------|-----|-----|-----|
| 16 | 25 | 32 | 40 | 50 | | A | B | P | T |
| x | x | x | x | x | GWA | A** | | P** | T** |
| x | x | x | x | x | GWB | | B** | P** | T** |

No code = NBR seals
 V = FKM seals
 (Other seals on enquiry)
⚠ Caution!
 Observe compatibility of seals with hydraulic fluid used!

⚠ Nozzle possible; indicate, if required

For ordering codes for nozzles, see page 14 and 15.

M-3SEW 6 C../420...

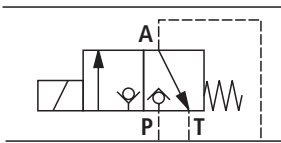

M-3SED 6 CK../350...

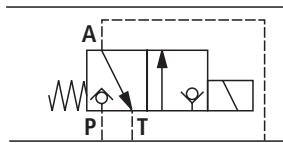

M-3SED 6 UK../350...
 M-3SEW 6 U../420...

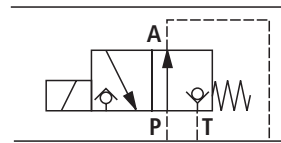

LFA . GWA...
 sizes 16 to 32

(with directional spool valve type 4WE 6 D...)

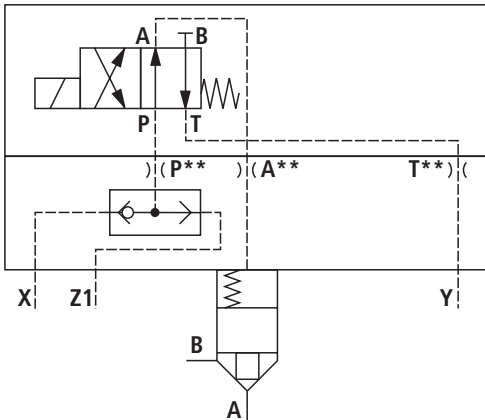

LFA . GWB...
 sizes 16 to 32

(with directional spool valve type 4WE 6 D...)

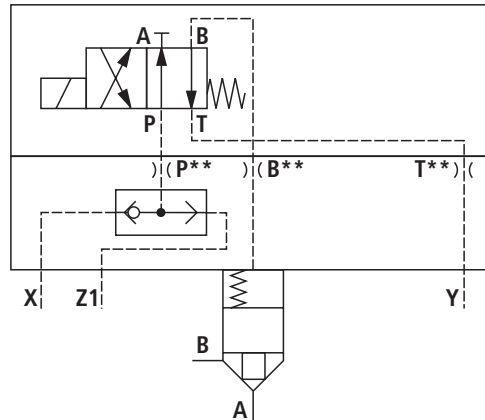

LFA . GWA...
 sizes 40 and 50

(with directional spool valve type 4WE 6 D...)

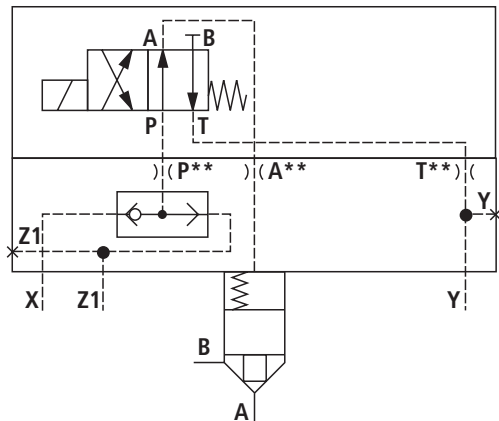

LFA . GWB...
 sizes 40 and 50

(with directional spool valve type 4WE 6 D...)

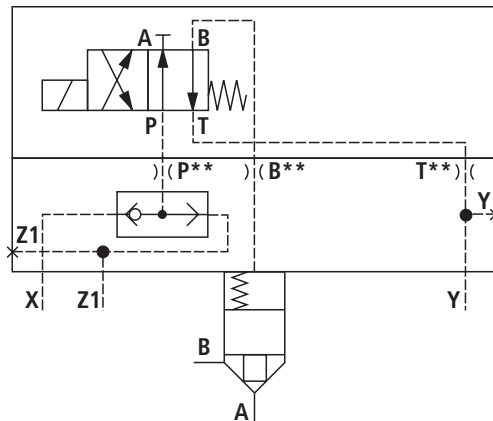

Control cover for mounting a directional spool valve: Type ..GWA..., ..GWB... (nominal dimensions in mm)

Sizes 16 to 50

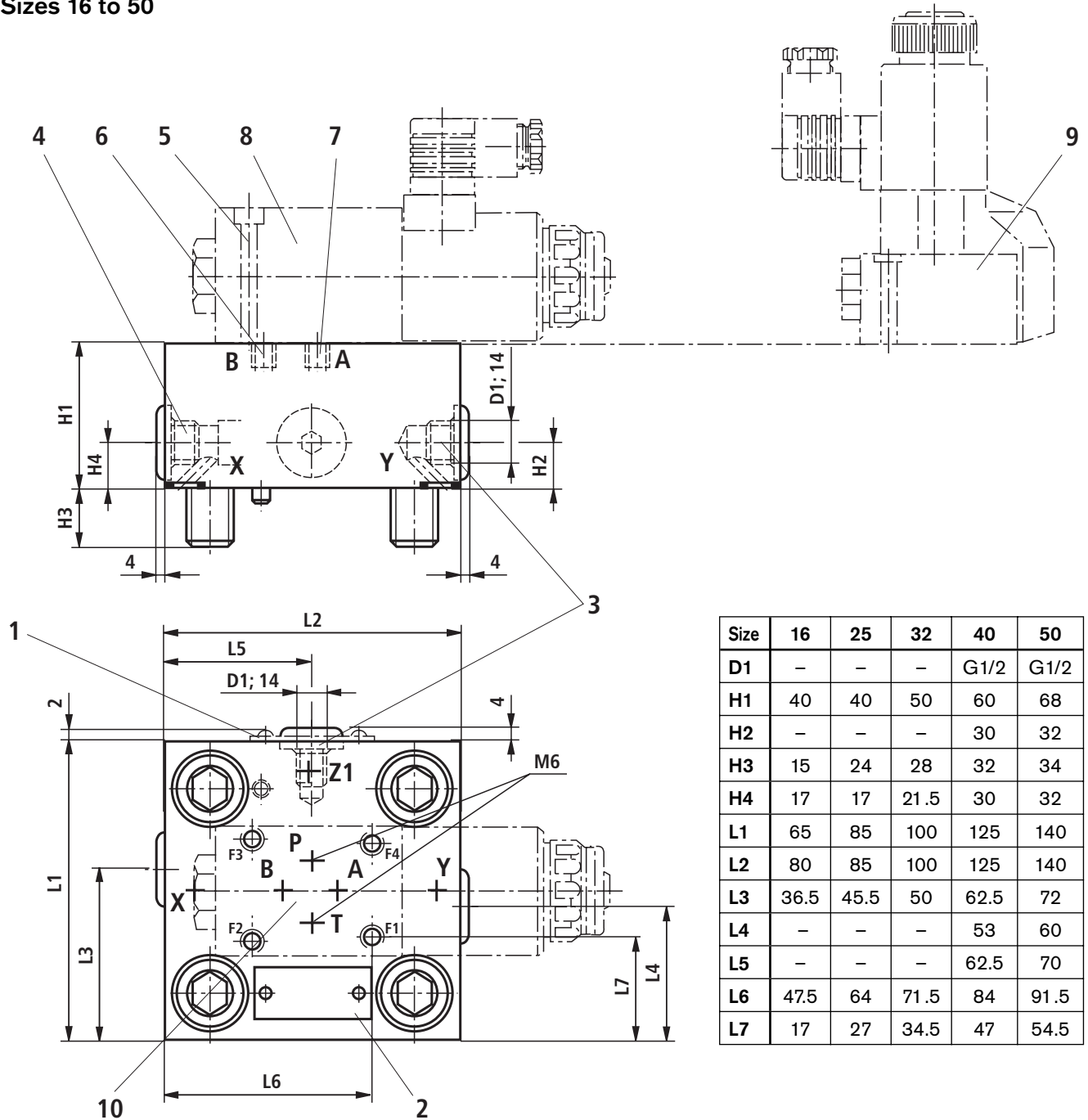

- 1 Nameplate for sizes 16, 25, 32
- 2 Nameplate for sizes 40 and 50
- 3 Ports Y and Z1 optionally as threaded connection for sizes 40 and 50
- 4 Shuttle valve
- 5 Valve fixing screws are included in the control cover's scope of supply

- 6 Plug screw M6 for ..GWA...
- 7 Plug screw M6 for ..GWB...
- 8 Directional spool valve type 4WE 6 D...
- 9 Directional poppet valve type M-3SEW 6 ...
- 10 Position of ports to ISO 4401-03-02-0-94

Control cover for mounting a directional spool or poppet valve: Type ..GWA..., ..GWB...

Size 63

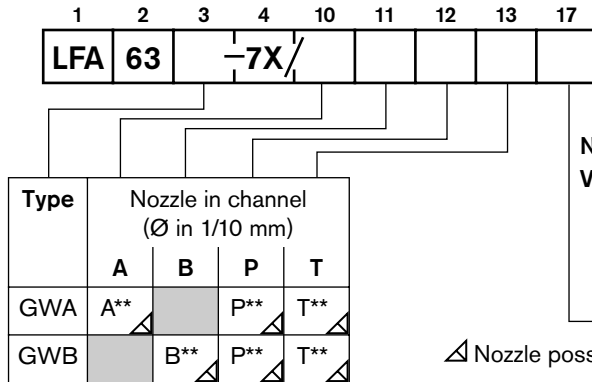

No code =
V =

NBR seals
FKM seals
(Other seals on enquiry)

⚠ Caution!

Observe compatibility of seals with hydraulic fluid used!

⚠ Nozzle possible; indicate, if required

For ordering codes for nozzles, see page 14 and 15.

M-3SEW 10 C../420...

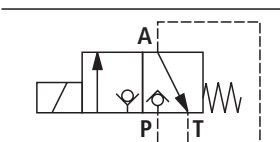

M-3SED 10 CK../350...

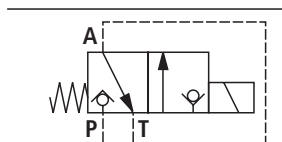

**M-3SED 10 UK../350...
M-3SEW 10 U../420...**

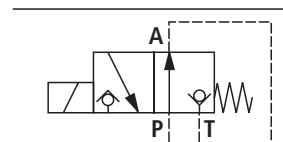

LFA 63 GWA...

(with directional spool valve type 4WE 10 D...)

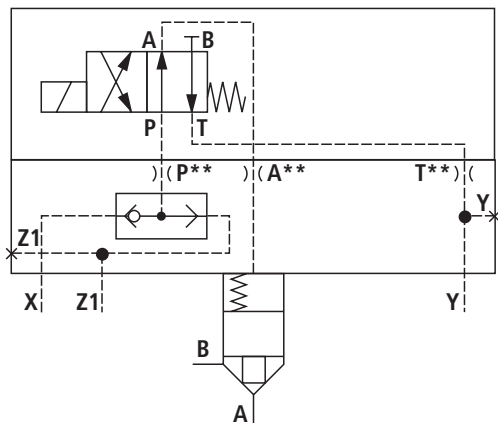

LFA 63 GWB...

(with directional spool valve type 4WE 10 D...)

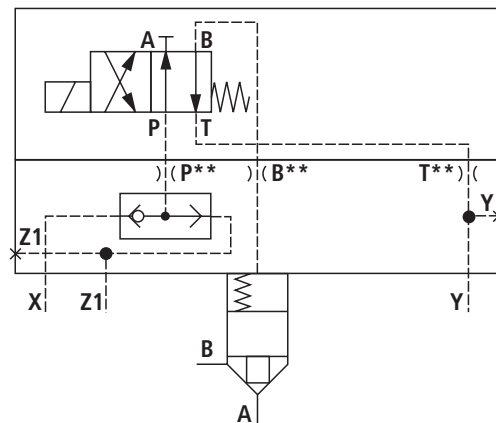

Control cover for mounting a directional spool or poppet valve: Type ..GWA..., ..GWB...

(nominal dimensions in mm)

Size 63

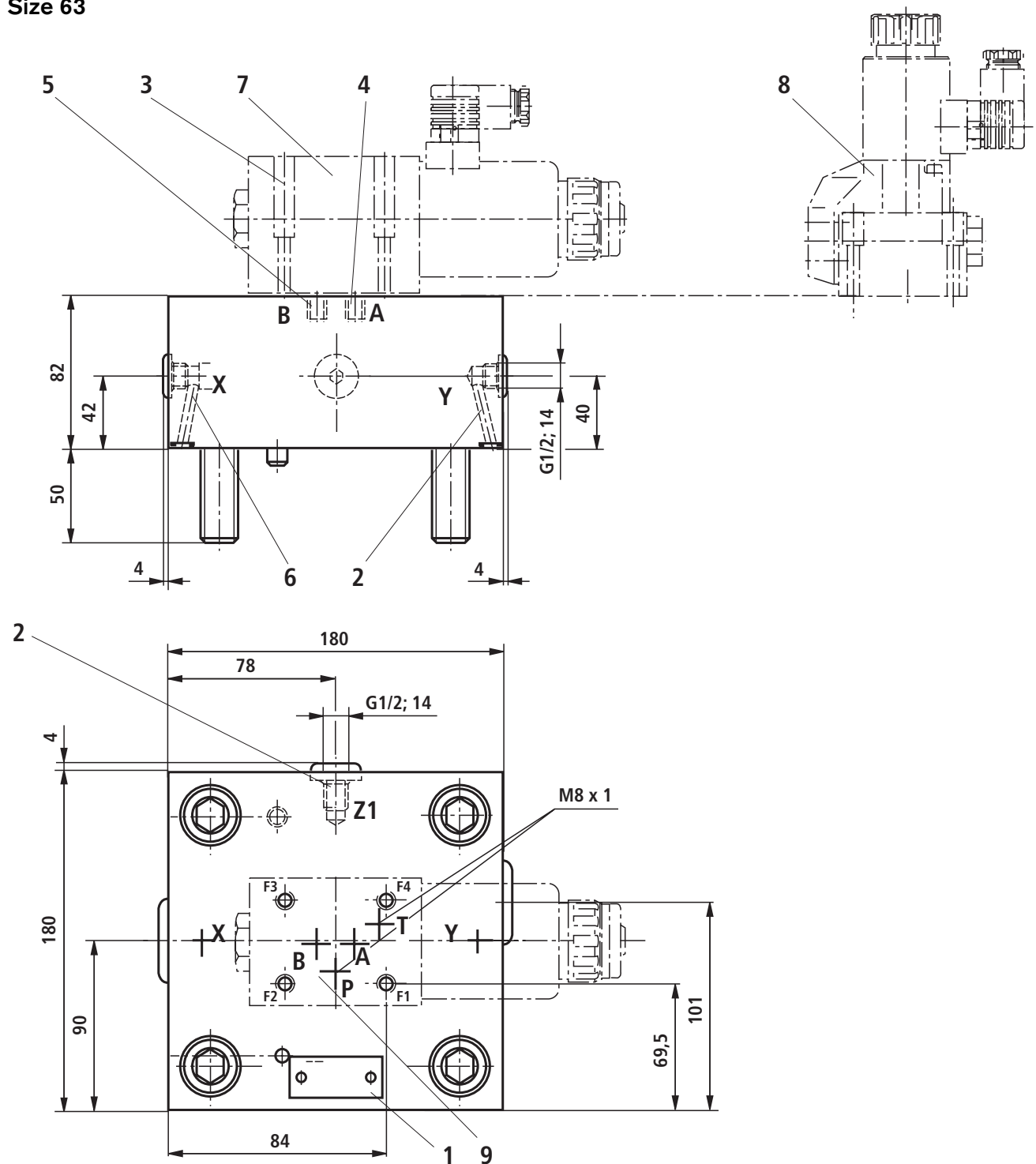

- | | |
|---|---|
| 1 Nameplate | 5 Plug screw M8 x 1 for type ..GWA.... |
| 2 Ports Y and Z1 optionally as threaded connection | 6 Shuttle valve |
| 3 Valve fixing screws are included in the control cover's scope of supply | 7 Directional spool valve type 4WE 10 D... |
| 4 Plug screw M8 x 1 for type ..GWB... | 8 Directional poppet valve type M-3SEW 10 ... |
| | 9 Position of ports to ISO 4401-05-04-0-94 |

Control cover for mounting a directional spool or poppet valve: Type ..GWA..., ..GWB...

Sizes 80 and 100

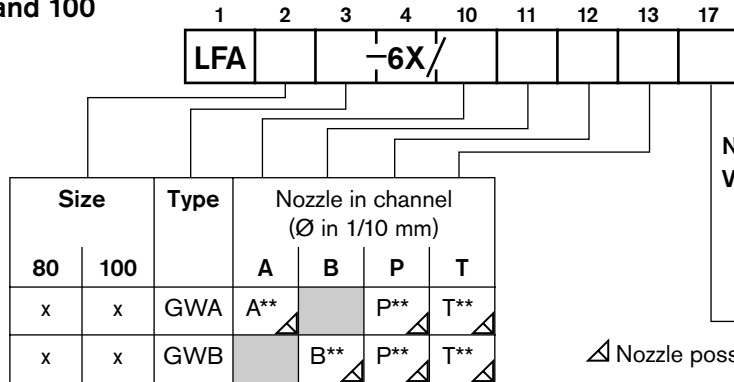

No code =
V =

NBR seals
FKM seals
(Other seals on enquiry)

⚠ Caution!

Observe compatibility of seals with hydraulic fluid used!

⚠ Nozzle possible; indicate, if required

For ordering codes for nozzles, see page 14 and 15.

M-3SEW 10 C../420...

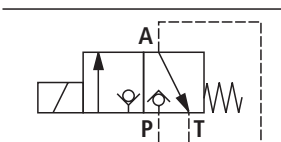

M-3SED 10 CK../350...

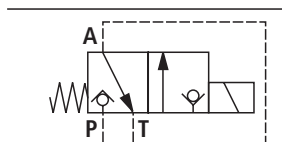

M-3SED 10 UK../350...
M-3SEW 10 U../420...

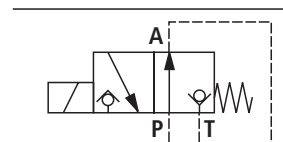

LFA . GWA...
sizes 80 and 100

(with directional spool valve type 4WE 10 D...)

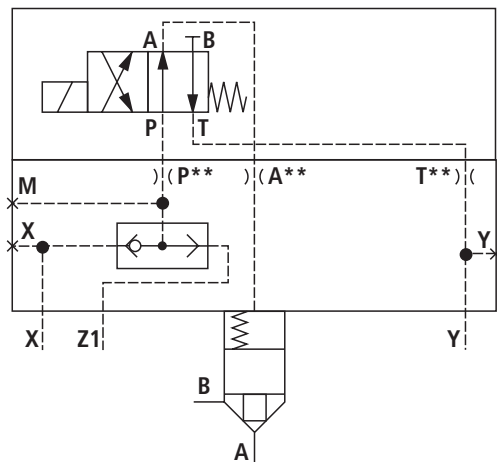

LFA . GWB...
sizes 80 and 100

(with directional spool valve type 4WE 10 D...)

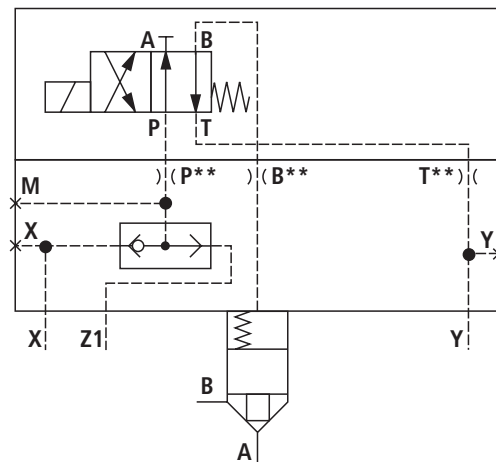

Control cover for mounting a directional spool or poppet valve: Type ..GWA..., ..GWB... (nominal dimensions in mm)

Sizes 80 and 100

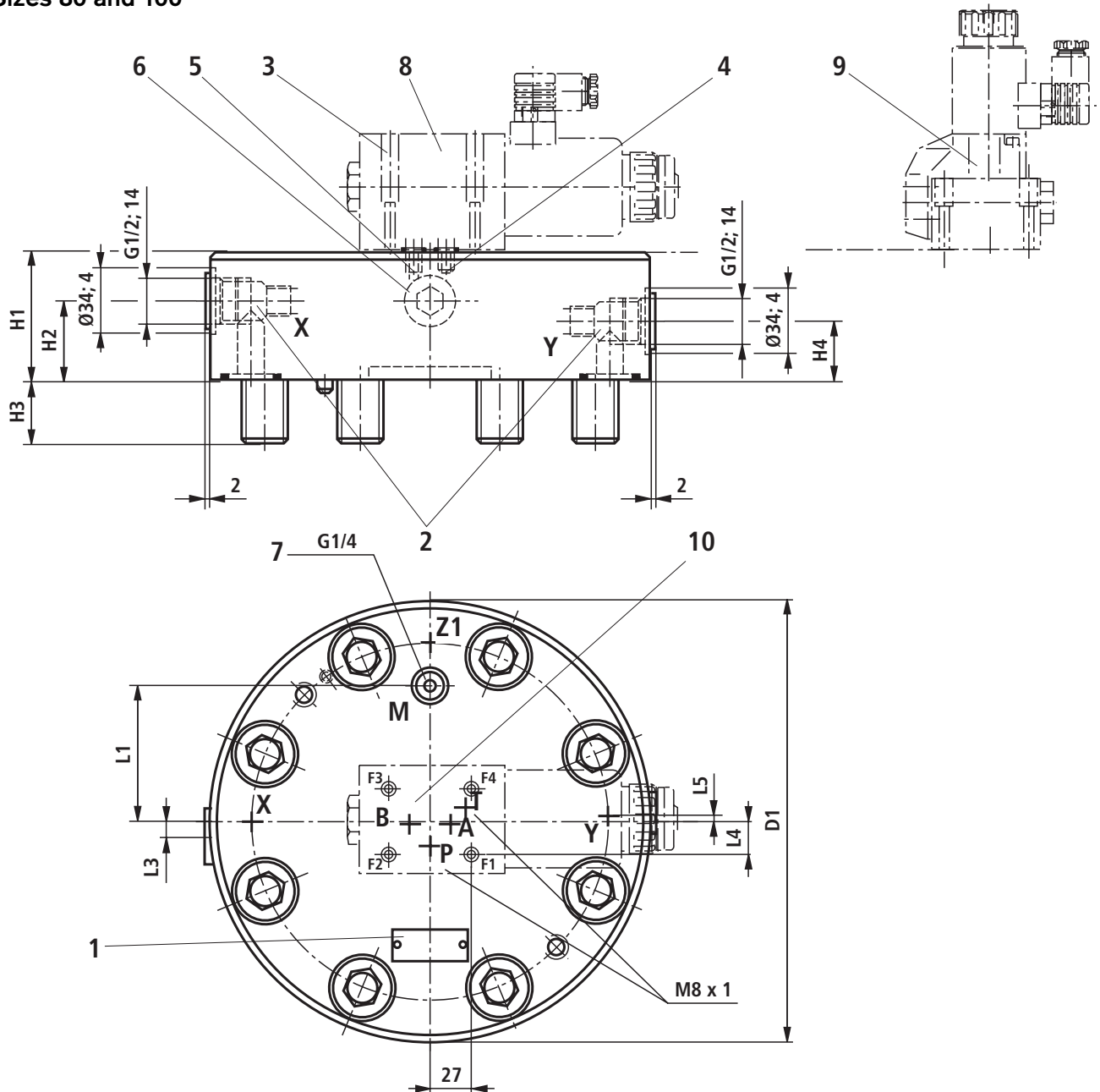

- 1 Nameplate
- 2 Ports X and Y optionally as threaded connection
- 3 Valve fixing screws are included in the control cover's scope of supply
- 4 Plug screw M8 x 1 for type ..GWB..
- 5 Plug screw M8 x 1 for type ..GWA..
- 6 Shuttle valve
- 7 Measuring port
- 8 Directional spool valve type 4WE 10 D...
- 9 Directional poppet valve type M-3SEW 10 ...
- 10 Position of ports to ISO 4401-05-04-0-94

| Size | 80 | 100 |
|------|------|------|
| D1 | 250 | 300 |
| H1 | 80 | 100 |
| H2 | 26 | 40 |
| H3 | 45 | 52.5 |
| H4 | 26 | 55 |
| L1 | 74 | 96.5 |
| L3 | 9.5 | 13 |
| L4 | 17 | 18 |
| L5 | 10.5 | 13 |

Control cover for mounting a directional spool or poppet valve: Type ..KWA..., ..KWB...

Sizes 16 to 50

| Size | Type | Nozzle in channel (Ø in 1/10 mm) | | | |
|------|------|----------------------------------|-----|-----|------|
| | | A | B | P | X |
| 16 | KWA | A** | | P15 | X15 |
| 25 | KWA | A** | | P15 | Ø2,0 |
| 32 | KWA | A** | | P20 | Ø2,5 |
| 40 | KWA | A** | | P20 | X30 |
| 50 | KWA | A** | | P20 | X30 |
| 16 | KWB | | B** | P15 | X15 |
| 25 | KWB | | B** | P15 | Ø2,0 |
| 32 | KWB | | B** | P20 | Ø2,5 |
| 40 | KWB | | B** | P20 | X30 |
| 50 | KWB | | B** | P20 | X30 |

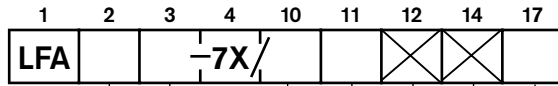

No code =
V =

NBR seals
FKM seals
(Other seals on enquiry)

⚠ Caution!

Observe compatibility of seals with hydraulic fluid used!

- ▲ Nozzle drilled (Ø in mm) ¹⁾
- △ Standard nozzle (Ø in 1/10 mm) ¹⁾
- ◁ Nozzle possible; indicate, if required (Ø in 1/10 mm)

¹⁾ Not shown in the type designation

For ordering codes for nozzles, see page 14 and 15.

M-3SEW 6 C../420...

M-3SED 6 CK../350...

M-3SED 6 UK../350...
M-3SEW 6 U../420...

4WE 6 D...
(for type LFA . KWA only)

4WE 6 D...
(for type LFA . KWB only)

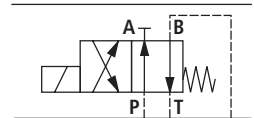
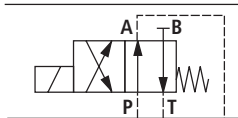
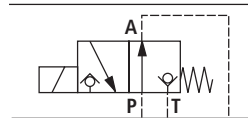
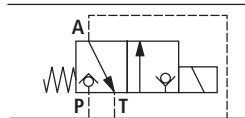
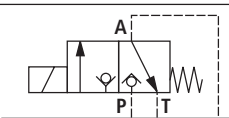

LFA . KWA...
size 16

(for directional valve, see above)

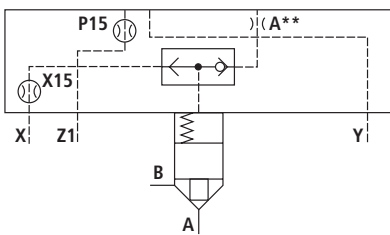

LFA . KWA...
sizes 25 and 32

(for directional valve, see above)

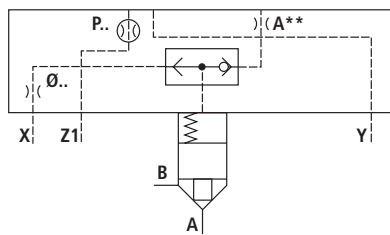

LFA . KWA...
sizes 40 and 50

(for directional valve, see above)

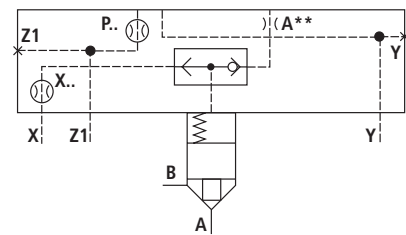

LFA . KWB...
size 16

(for directional valve, see above)

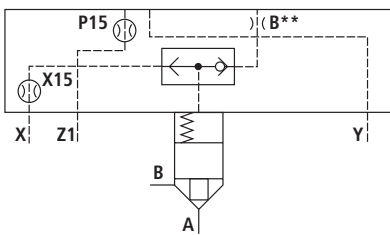

LFA . KWB...
sizes 25 and 32

(for directional valve, see above)

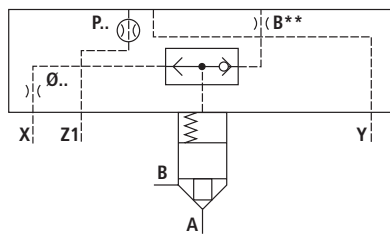

LFA . KWB...
sizes 40 and 50

(for directional valve, see above)

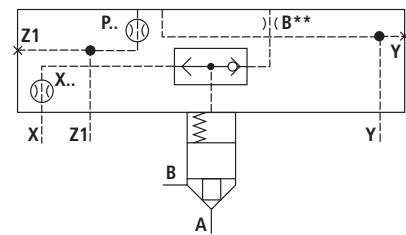

Control cover for mounting a directional spool or poppet valve: Type ..KWA..., ..KWB...

(nominal dimensions in mm)

Sizes 16 to 50

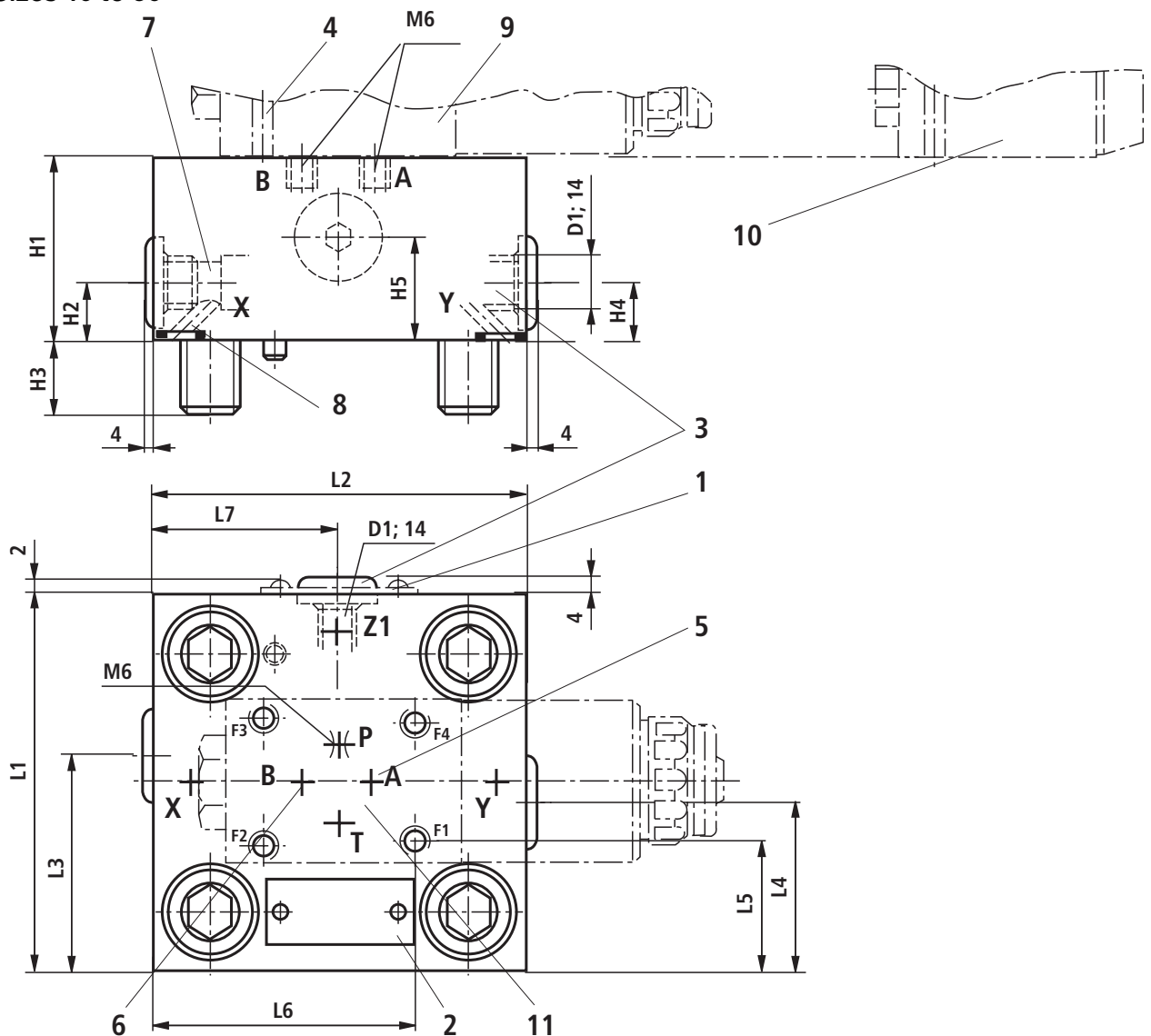

- 1 Nameplate for sizes 16, 25 and 32
- 2 Nameplate for sizes 40 and 50
- 3 Ports Y and Z1 optionally as threaded connection for sizes 40 and 50
- 4 Valve fixing screws are included in the control cover's scope of supply
- 5 Plug screw ..KWB...
- 6 Plug screw ..KWA...
- 7 Shuttle valve
- 8 M6 for sizes 16 and 40, M8 x 1 for size 50
- 9 Directional spool valve type 4WE 6 D...
- 10 Directional poppet valve type M-3SEW 6 ...
- 11 Position of ports to ISO 4401-03-02-0-94

| Size | 16 | 25 | 32 | 40 | 50 |
|------|------|------|------|------|------|
| D1 | - | - | - | G1/2 | G1/2 |
| H1 | 40 | 40 | 50 | 60 | 68 |
| H2 | 17 | 17 | 21.5 | 30 | 32 |
| H3 | 15 | 24 | 28 | 32 | 34 |
| H4 | - | - | - | 30 | 32 |
| H5 | - | - | - | 30 | 50 |
| L1 | 65 | 85 | 100 | 125 | 140 |
| L2 | 80 | 85 | 100 | 125 | 140 |
| L3 | 36.5 | 45.5 | 50 | 62.5 | 72 |
| L4 | - | - | - | 53 | 60 |
| L5 | 17 | 27 | 34.5 | 47 | 54.5 |
| L6 | 47.5 | 64 | 71.5 | 84 | 91.5 |
| L7 | - | - | - | 62.5 | 70 |

Control cover for mounting a directional spool or poppet valve: Type ..KWA..., ..KWB...

Size 63

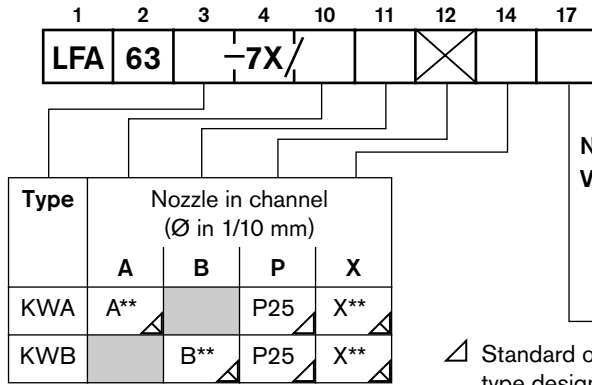

| Type | Nozzle in channel (Ø in 1/10 mm) | | | |
|------|-------------------------------------|-----|-----|-----|
| | A | B | P | X |
| KWA | A** | | P25 | X** |
| KWB | | B** | P25 | X** |

No code =
V =

NBR seals
FKM seals
(Other seals on enquiry)

⚠ Caution!

Observe compatibility of seals with hydraulic fluid used!

⚠ Standard nozzle (Ø in 1/10 mm) – is not shown in the type designation

⚠ Nozzle possible; indicate, if required (Ø in 1/10 mm)

For ordering codes for nozzles, see pages 14 and 15.

M-3SEW 10 C../420...

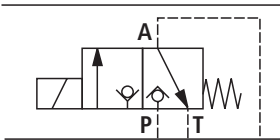

M-3SED 10 CK../350...

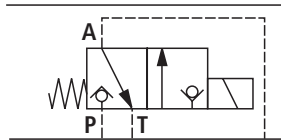

**M-3SED 10 UK../350...
M-3SEW 10 U../420...**

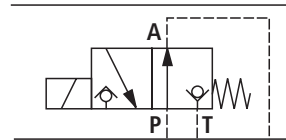

LFA 63 KWA...

(with directional spool valve type 4WE 10 D...)

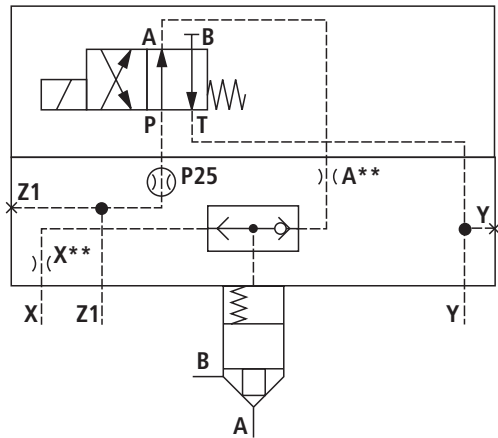

LFA 63 KWB...

(with directional spool valve type 4WE 10 D...)

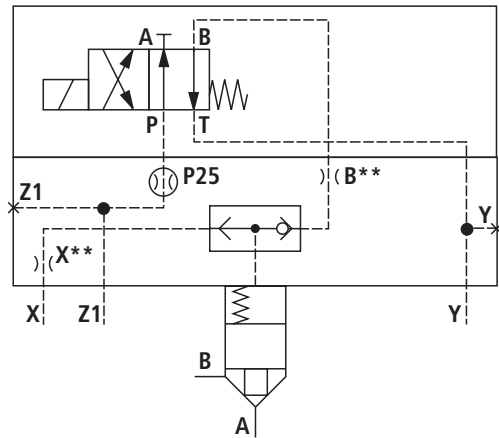

Control cover for mounting a directional spool or poppet valve: Type ..KWA..., ..KWB...
(nominal dimensions in mm)

Size 63

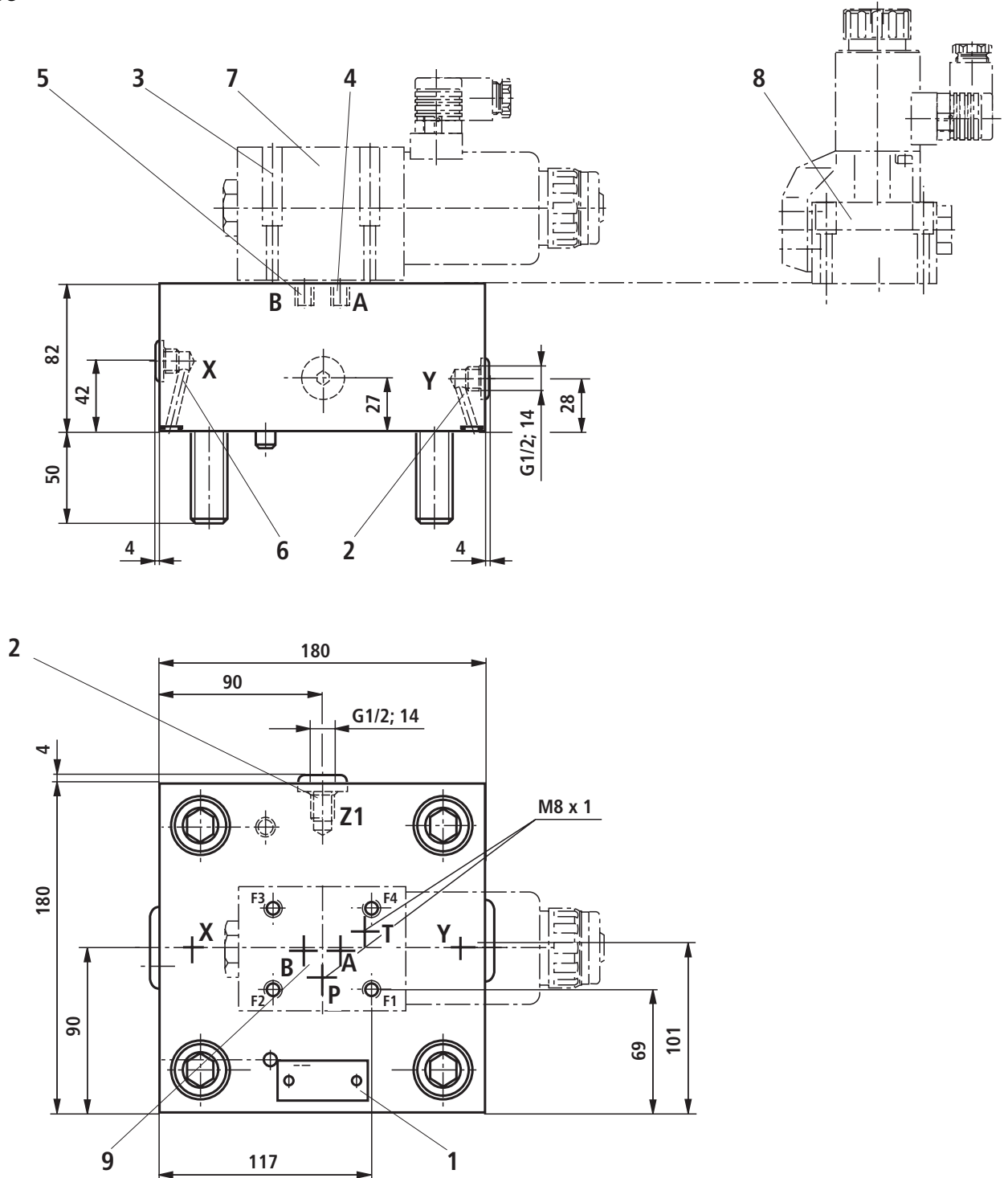

- | | |
|--|--|
| <p>1 Nameplate</p> <p>2 Ports Y and Z1 optionally as threaded connection</p> <p>3 Valve fixing screws are included in the control cover's scope of supply</p> <p>4 Plug screw M8 x 1 for type ..KWB...</p> | <p>5 Plug screw M8 x 1 for type ..KWA...</p> <p>6 Shuttle valve</p> <p>7 Directional spool valve type 4WE 10 D...</p> <p>8 Directional poppet valve type M-3SEW 10 ...</p> <p>9 Position of ports to ISO 4401-03-02-0-94</p> |
|--|--|

Control cover for mounting a directional spool or poppet valve: Type ..KWA..., ..KWB...

Sizes 80 and 100

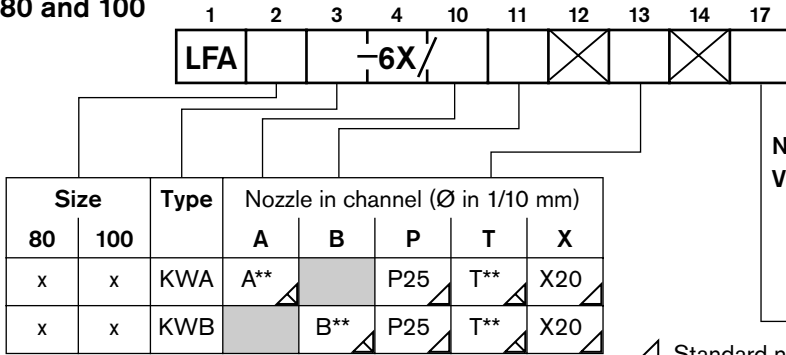

No code =
V =

NBR seals
FKM seals
(Other seals on enquiry)

⚠ Caution!

Observe compatibility of seals with hydraulic fluid used!

| Size | | Type | Nozzle in channel (Ø in 1/10 mm) | | | | |
|------|-----|------|----------------------------------|-----|-----|-----|-----|
| 80 | 100 | | A | B | P | T | X |
| x | x | KWA | A** | | P25 | T** | X20 |
| x | x | KWB | | B** | P25 | T** | X20 |

- △ Standard nozzle – is not shown in the type designation
- ◻ Nozzle possible; indicate, if required

For ordering codes for nozzles, see page 14 and 15.

M-3SEW 10 C../420...

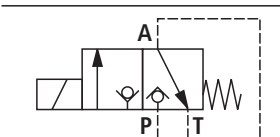

M-3SED 10 CK../350...

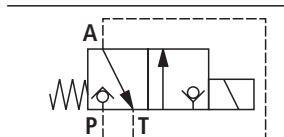

M-3SED 10 UK../350...
M-3SEW 10 U../420...

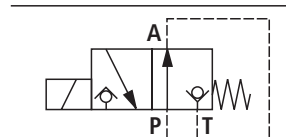

LFA . KWA...
sizes 80 and 100

(with directional spool valve type 4WE 10 D...)

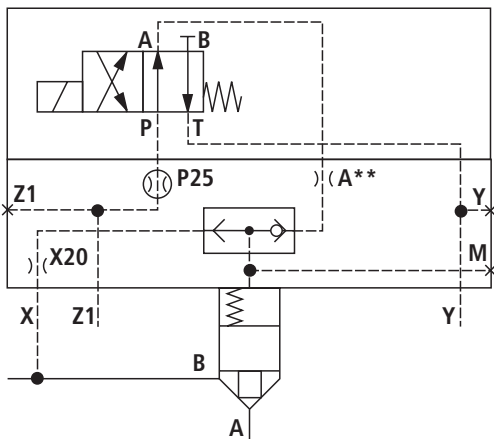

LFA . KWB...
sizes 80 and 100

(with directional spool valve type 4WE 10 D...)

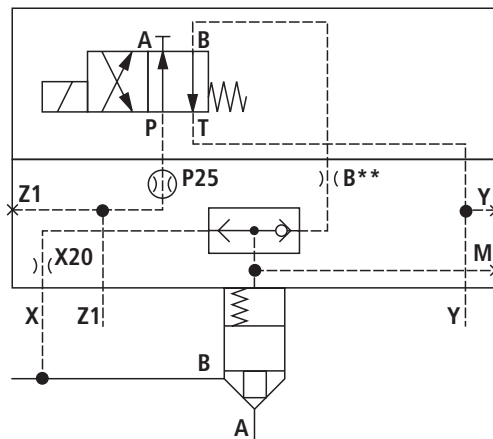

Control cover for mounting a directional spool or poppet valve: Type ..KWA..., ..KWB...
(nominal dimensions in mm)

Sizes 80 and 100

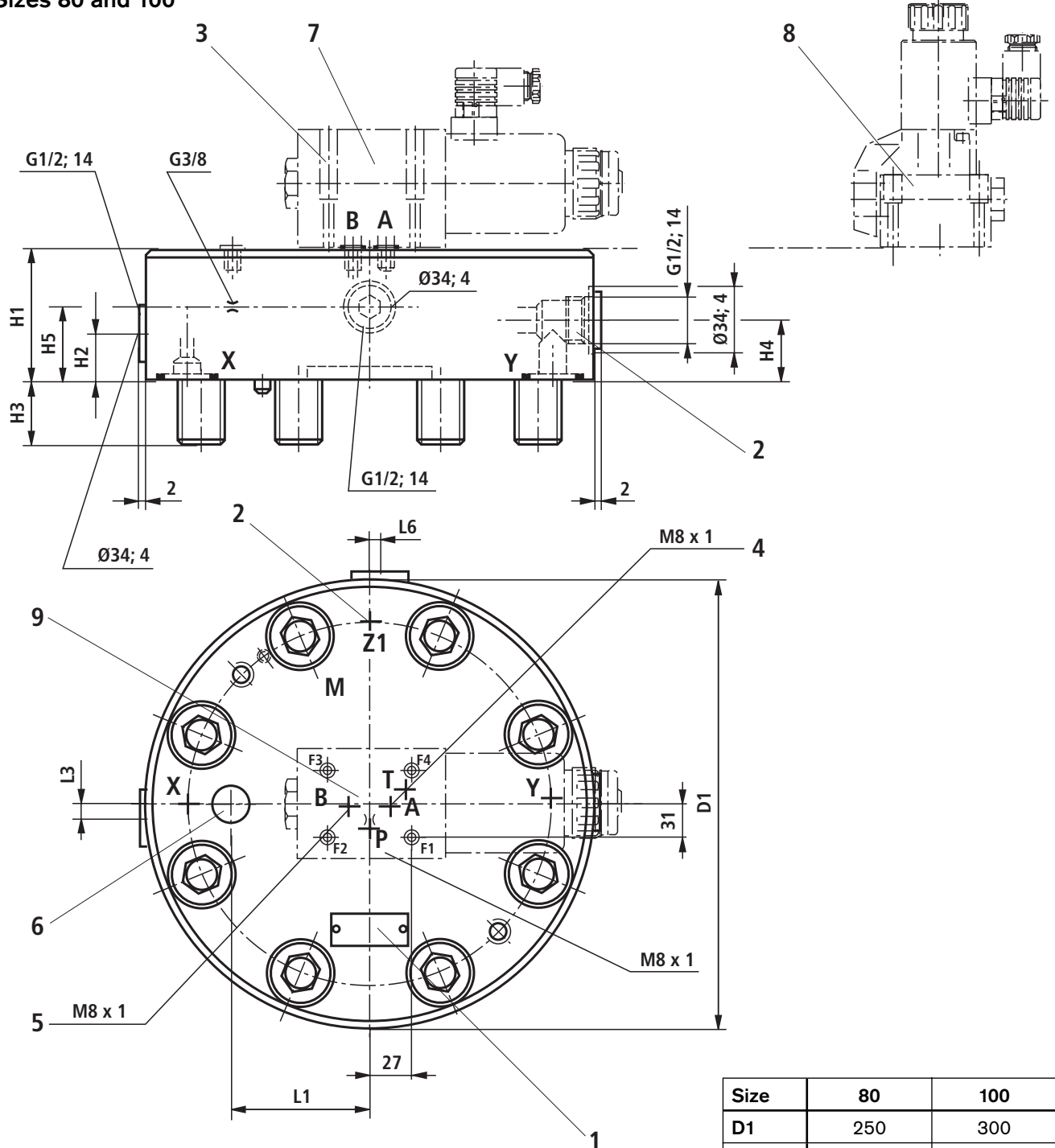

- 1 Nameplate
- 2 Ports Y and Z1 optionally as threaded connection
- 3 Valve fixing screws are included in the control cover's scope of supply
- 4 Plug screw ..KWB...
- 5 Plug screw ..KWA...
- 6 Shuttle valve
- 7 Directional spool valve type 4WE 10 D...
- 8 Directional poppet valve type M-3SEW 10 ...
- 9 Position of ports to ISO 4401-05-04-0-94

| Size | 80 | 100 |
|------|------|------|
| D1 | 250 | 300 |
| H1 | 100 | 110 |
| H2 | 19.5 | 27 |
| H3 | 45 | 52.5 |
| H4 | 60 | 70 |
| H5 | 52 | 62 |
| L1 | 55 | 62 |
| L3 | 6.5 | 5 |
| L6 | 6.5 | 2 |

Control cover with electrical monitor of the closed position: Type ..E... (monitoring of the closed position)

Technical data and notes are valid for all listed control covers with electrical monitor (E, EH2, EWA and EWB).

The contact-free position switch with integrated amplifier switches after having reached the switching position. This position switch offers the following advantages:

- No dynamic seals
- Direct monitoring of the closed position of the valve
- Long service life
- **Control cover and cartridge valve included completely in this type**
- $p_{max} = 400 \text{ bar}$

Position switch

For connection, functions, pin assignment, see page 66.

⚠ Caution!

Outputs of the position switch protected only from load short-circuit.

Prevent short-circuit of the outputs against +24 V.

Sizes 16 to 63

| | | | | | | | | | | | | | | | | | | | | | |
|-----|--|---|--|---|--|-----|--|---|--|---|--|-------|--|---|--|---|--|----|--|----|--|
| 1 | | 2 | | 3 | | 4 | | 5 | | 6 | | 7 | | 8 | | 9 | | 14 | | 17 | |
| LFA | | | | E | | 7X/ | | | | D | | QMG24 | | F | | | | | | | |

| Size | | | | | |
|------|----|----|----|----|----|
| 16 | 25 | 32 | 40 | 50 | 63 |
| x | x | x | x | x | x |

| Area ratio A1: A2 | Cracking pressure p_{δ} | Nozzle in channel (\varnothing in 1/10 mm) |
|---------------------------|-----------------------------------|--|
| CA = 2:1 ¹⁾ | 10 = 1.0 bar | X** |
| CB = 14.3:1 ²⁾ | 20 = 2.0 bar | |
| | 40 = 4.0 bar | |

No code =
V =

NBR seals
FKM seals
(Other seals on enquiry)
⚠ Caution!
Observe compatibility of seals with
hydraulic fluid used!

⚠ Nozzle possible; indicate, if required

QM = Inductive position switch, see page 66

G24 = 24 V DC voltage

For ordering codes for nozzles, see page 14 and 15.

¹⁾ Annulus area = 50% (standard version)

²⁾ Annulus area = 7%

LFA . E... sizes 16 to 63

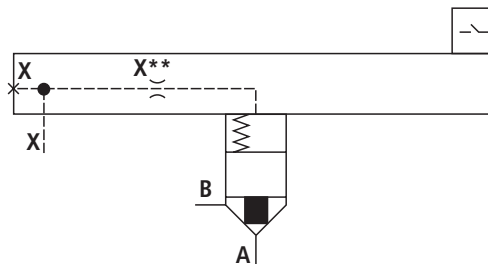

Control cover with electrical monitor of the closed position: Type ..E...
 (monitoring of the closed position) (nominal dimensions in mm)

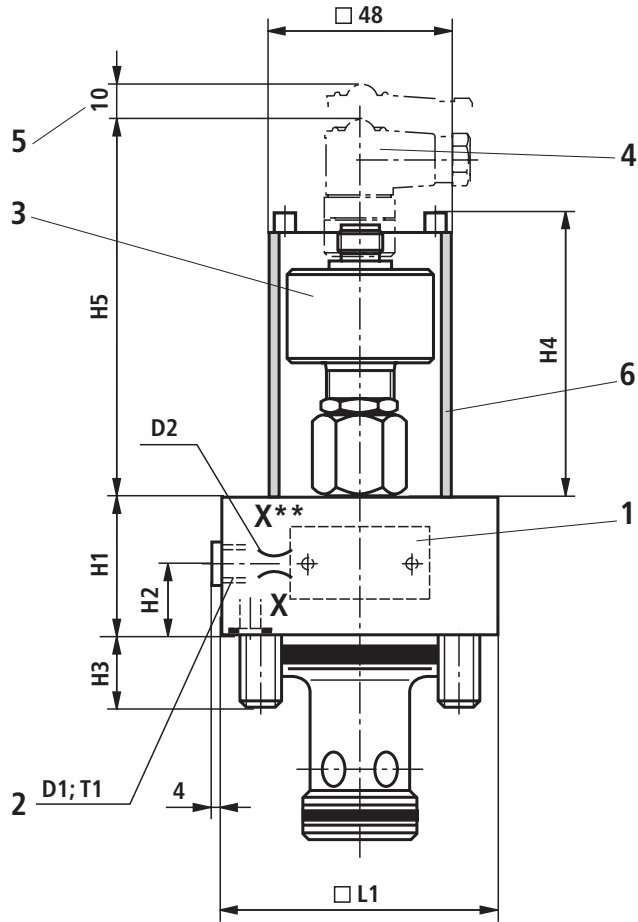

| Size | 16 | 25 | 32 | 40 | 50 | 63 |
|------|------|------|------|--------|--------|--------|
| D1 | G1/8 | G1/4 | G1/4 | G1/2 | G1/2 | G3/4 |
| D2 | M6 | M6 | M6 | M8 x 1 | M8 x 1 | M8 x 1 |
| H1 | 50 | 50 | 70 | 110 | 120 | 150 |
| H2 | 12 | 16 | 16 | 83 | 93 | 113 |
| H3 | 15 | 24 | 28 | 32 | 34 | 50 |
| H4 | 78 | 78 | 78 | 98 | 98 | 98 |
| H5 | 105 | 105 | 105 | 123 | 123 | 123 |
| □ L1 | 65 | 85 | 100 | 125 | 140 | 180 |
| T1 | 8 | 12 | 12 | 14 | 14 | 16 |

- 1 Nameplate
- 2 Port X optionally as threaded connection
- 3 Position switch type QM (included in the type, see page 66)
- 4 Cable socket Z24 (separate order, see page 66)
- 5 Space required to remove cable socket
- 6 Protective cap

Control cover with electrical monitor of the closed position and stroke limiter: Type ..EH2...
(monitoring of the closed position)

Sizes 16 to 40

| | | | | | | | | | | | |
|--|-----|---|-----|-----|---|---|---|-------|---|----|----|
| | 1 | 2 | 3 | 4 | 5 | 6 | 7 | 8 | 9 | 14 | 17 |
| | LFA | | EH2 | -7X | / | | D | QMG24 | F | | |

| | | | |
|-------------|----|----|----|
| Size | | | |
| 16 | 25 | 32 | 40 |
| x | x | x | x |

| | | |
|------------------------------|---|--|
| Area ratio A1: A2 | Cracking pressure $p_{\bar{o}}$ | Nozzle in channel (\varnothing in 1/10 mm) |
| CA = 2:1 ¹⁾ | 10 = 1.0 bar | X** |
| CB = 14.3:1 ²⁾ | 20 = 2.0 bar | |
| | 40 = 4.0 bar | |

No code = NBR seals
V = FKM seals
 (Other seals on enquiry)
⚠ Caution!
 Observe compatibility of seals with hydraulic fluid used!

⚠ Nozzle possible; indicate, if required

QM = Inductive position switch, see page 66

G24 = 24 V DC voltage

For ordering codes for nozzles, see page 14 and 15.

¹⁾ Annulus area = 50% (standard version)

²⁾ Annulus area = 7%

LFA . EH2...
sizes 16 and 32

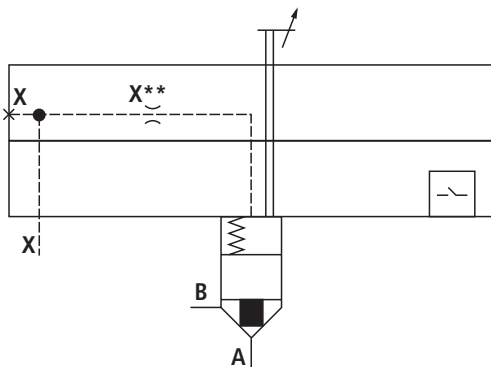

LFA . EH2...
size 40

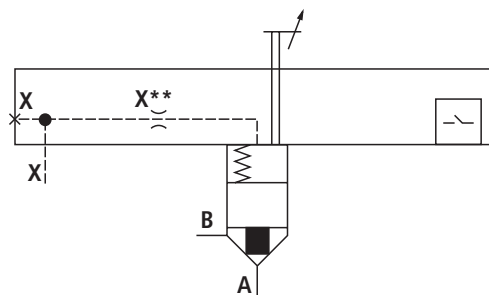

Control cover with electrical monitor of the closed position and stroke limiter: Type ..EH2...
 (monitoring of the closed position) (nominal dimensions in mm)

Sizes 16 to 32

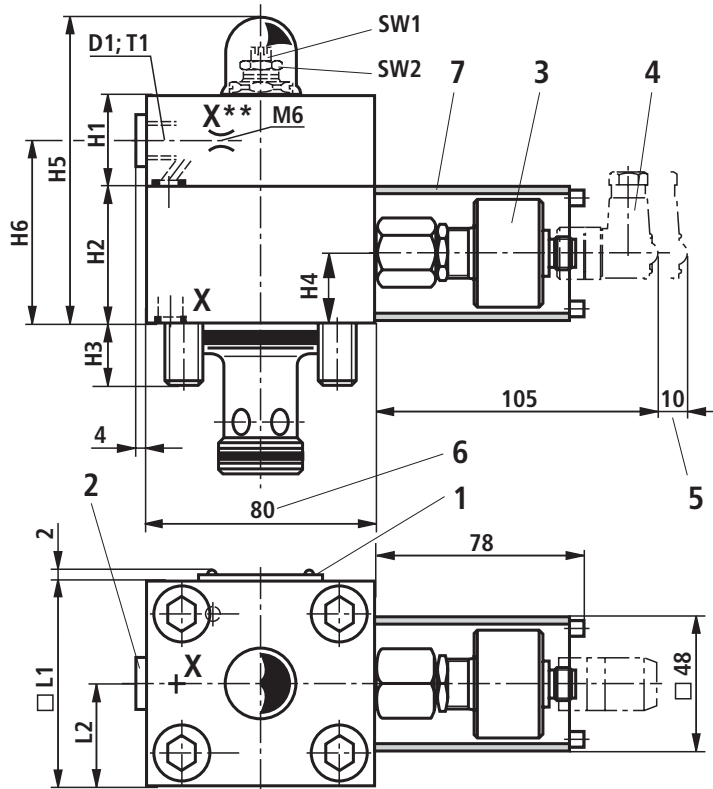

Size 40

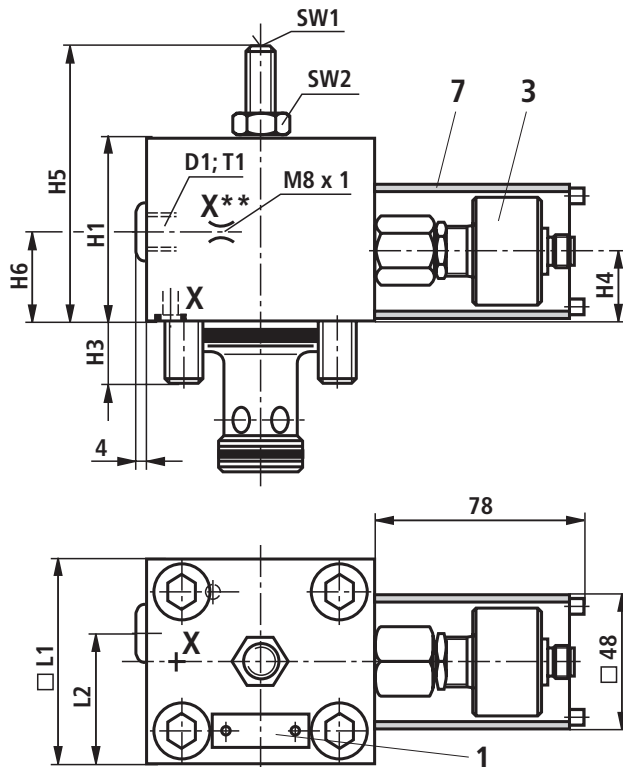

| Size | 16 | 25 | 32 | 40 |
|------|------|------|-------------------|-------------------|
| D1 | G1/8 | G1/4 | G1/4 | G1/2 |
| H1 | 35 | 40 | 50 | 182 |
| H2 | 50 | 50 | 50 | - |
| H3 | 15 | 24 | 28 | 32 |
| H4 | 25 | 25 | 25 | 25 |
| H5 | 126 | 130 | 150 ³⁾ | 233 ³⁾ |
| H6 | 62 | 66 | 66 | 88 |
| □ L1 | 65 | 85 | 100 | 125 |
| L2 | 32.5 | 42.5 | 50 | 62.5 |
| T1 | 8 | 12 | 12 | 14 |
| A/F1 | 6 | 6 | 10 | 14 |
| A/F2 | 21 | 21 | 27 | 46 |

³⁾ Maximum dimension

- 1 Nameplate
- 2 Port X optionally as threaded connection
- 3 Position switch type QM (included in type, see page 66)
- 4 Cable socket Z24 (separate order, see page 66)
- 5 Space required to remove cable socket
- 6 For size 16 (lower cover only)
- 7 Protective cap

Control cover with electrical monitor of the closed position for mounting a directional spool or poppet valve: Type ..EWA..., ..EWB... (monitoring of the closed position)

Sizes 16 to 32

| | | | | | | | | | | | | | | | | | | | | | | | | | |
|-----|--|---|--|---|--|------|--|---|--|---|--|-------|--|---|--|----|--|----|--|----|--|----|--|----|--|
| 1 | | 2 | | 3 | | 4 | | 5 | | 6 | | 7 | | 8 | | 10 | | 11 | | 12 | | 13 | | 17 | |
| LFA | | | | | | -7X/ | | | | D | | QMG24 | | | | | | | | | | | | | |

| Size | | | Type |
|------|----|----|------|
| 16 | 25 | 32 | |
| x | x | x | EWA |
| x | x | x | EWB |

| Area ratio A1: A2 | Cracking pressure $p_{\dot{o}}$ |
|---------------------------|------------------------------------|
| CA = 2:1 ¹⁾ | 10 = 1.0 bar |
| CB = 14.3:1 ²⁾ | 20 = 2.0 bar |
| | 40 = 4.0 bar |

| Nozzle in channel (\varnothing in 1/10 mm) | | | |
|--|-----|-----|-----|
| A | B | P | T |
| A** | | P** | T** |
| | B** | P** | T** |

No code = NBR seals
V = FKM seals
(Other seals on enquiry)
⚠ Caution!
Observe compatibility of seals with hydraulic fluid used!

⚠ Nozzle possible; indicate, if required

QM = Inductive position switch, see page 66

G24 = 24 V DC voltage

For ordering codes for nozzles, see page 14 and 15.

¹⁾ Annulus area = 50% (standard version)

²⁾ Annulus area = 7%

M-3SEW 6 C../420...

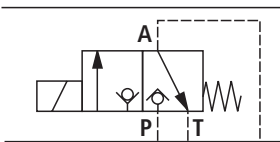

M-3SED 6 CK../350...

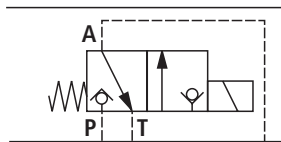

**M-3SED 6 UK../350...
M-3SEW 6 U../420...**

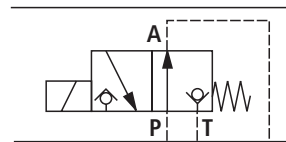

**LFA . EWA...
sizes 16 to 32**

(with directional spool valve type 4WE 6 D...)

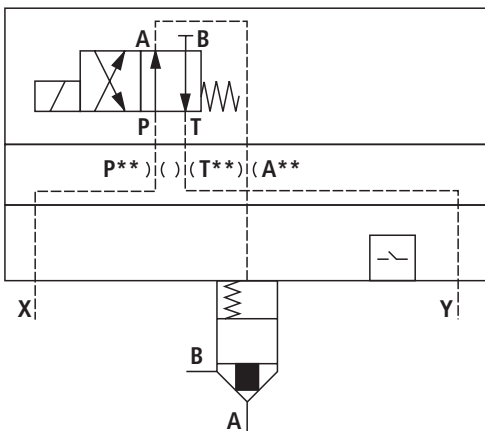

**LFA . EWB...
sizes 16 to 32**

(with directional spool valve type 4WE 6 D...)

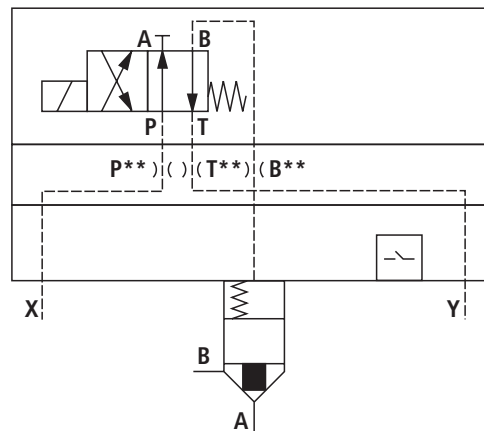

Control cover with electrical monitor of the closed position for mounting a directional spool or poppet valve: Type ..EWA..., ..EWB... (monitoring of the closed position) (nominal dimensions in mm)

Sizes 16 to 32

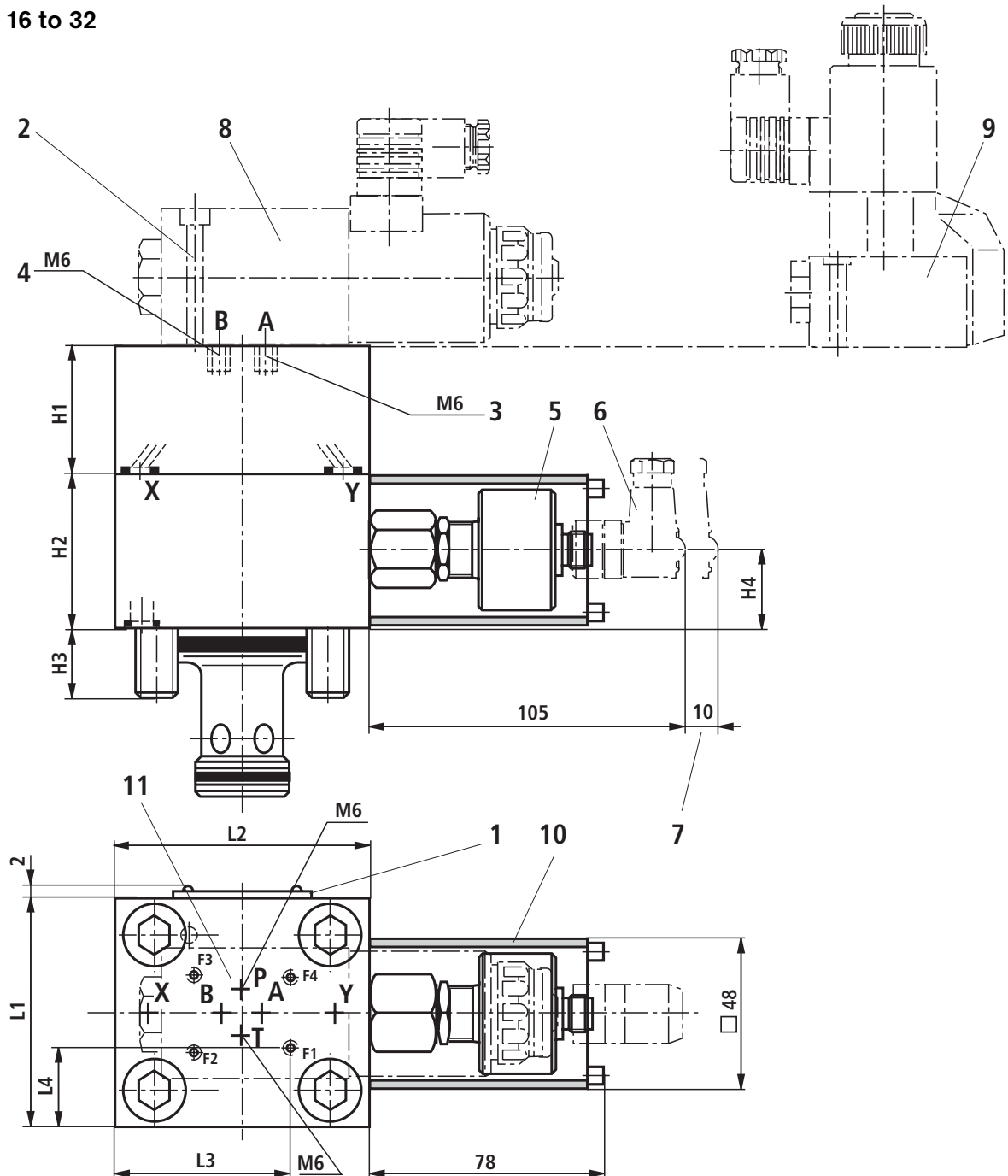

- | | |
|--|---|
| <p>1 Nameplate</p> <p>2 Valve fixing screws are included in the control cover's scope of supply</p> <p>3 Plug screw M6 for type ..EWB...</p> <p>4 Plug screw M6 for type ..EWA...</p> <p>5 Position switch type QM (included in type, see page 66)</p> | <p>6 Cable socket Z24 (separate order, see page 66)</p> <p>7 Space required to remove cable socket</p> <p>8 Directional spool valve type 4WE 6 D...</p> <p>9 Directional poppet valve type M-3SEW 6 ...</p> <p>10 Protective cap</p> <p>11 Position of ports to ISO 4401-03-02-0-94</p> |
|--|---|

| Size | 16 | 25 | 32 |
|------|-------|-------|-------|
| H1 | 40 | 40 | 50 |
| H2 | 50 | 50 | 50 |
| H3 | 15 | 24 | 28 |
| H4 | 25 | 25 | 25 |
| L1 | 65 | 85 | 100 |
| L2 | 80 | 85 | 100 |
| L3 | 47.5 | 64 | 71.5 |
| L4 | 17.25 | 27.25 | 34.75 |

Control cover with electrical monitor of the closed position for mounting a directional spool or poppet valve: Type ..EWA..., ..EWB... (monitoring of the closed position)

Sizes 40 and 50

| | | | | | | | | | | | | | | | | | | | | | | | | | |
|-----|--|---|--|---|--|------|--|---|--|---|--|-------|--|---|--|----|--|----|--|----|--|----|--|----|--|
| 1 | | 2 | | 3 | | 4 | | 5 | | 6 | | 7 | | 8 | | 10 | | 11 | | 12 | | 13 | | 17 | |
| LFA | | | | | | -7X/ | | | | D | | QMG24 | | | | | | | | | | | | | |

| Size | | Type |
|------|----|------|
| 40 | 50 | |
| x | x | EWA |
| x | x | EWB |

| Area ratio A1: A2 | |
|---------------------------|--|
| CA = 2:1 ¹⁾ | |
| CB = 14.3:1 ²⁾ | |

| Cracking pressure $p_{\bar{o}}$ | |
|---------------------------------|--|
| 10 = 1.0 bar | |
| 20 = 2.0 bar | |
| 40 = 4.0 bar | |

| Nozzle in channel (Ø in 1/10 mm) | | | |
|----------------------------------|-----|-----|-----|
| A | B | P | T |
| A** | | P** | T** |
| | B** | P** | T** |

No code = NBR seals
 V = FKM seals
 (Other seals on enquiry)

⚠ Caution!
 Observe compatibility of seals with hydraulic fluid used!

⚠ Nozzle possible; indicate, if required

QM = Inductive position switch, see page 66

G24 = 24 V DC voltage

For ordering codes for nozzles, see page 14 and 15.

¹⁾ Annulus area = 50% (standard version)

²⁾ Annulus area = 7%

M-3SEW 6 C../420...

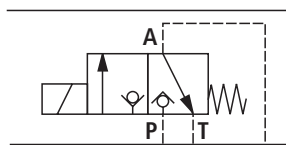

**M-3SED 6 UK../350...
M-3SEW 6 U../420...**

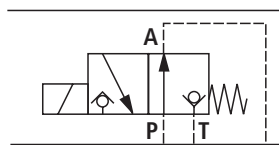

**LFA . EWA...
sizes 40 and 50**

(with directional spool valve type 4WE 6 D...)

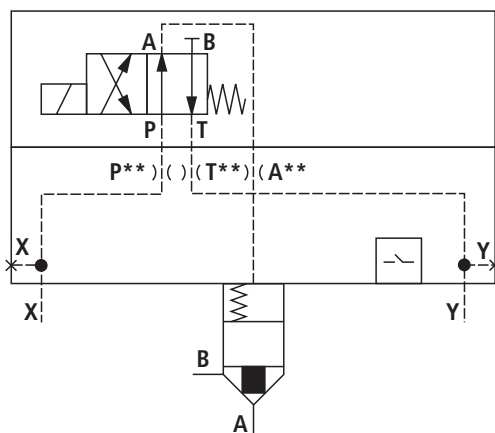

**LFA . EWB...
sizes 40 and 50**

(with directional spool valve type 4WE 6 D...)

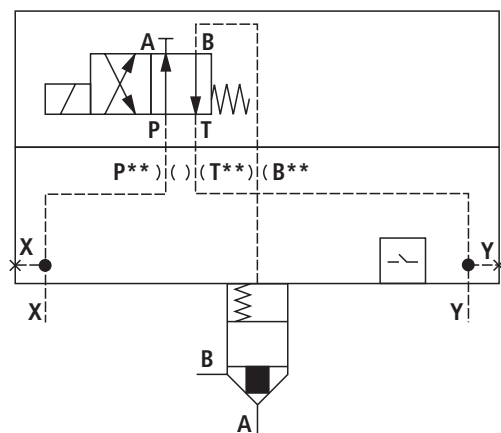

Control cover with electrical monitor of the closed position for mounting a directional spool or poppet valve: Type ..EWA..., ..EWB... (monitoring of the closed position) (nominal dimensions in mm)

Sizes 40 and 50

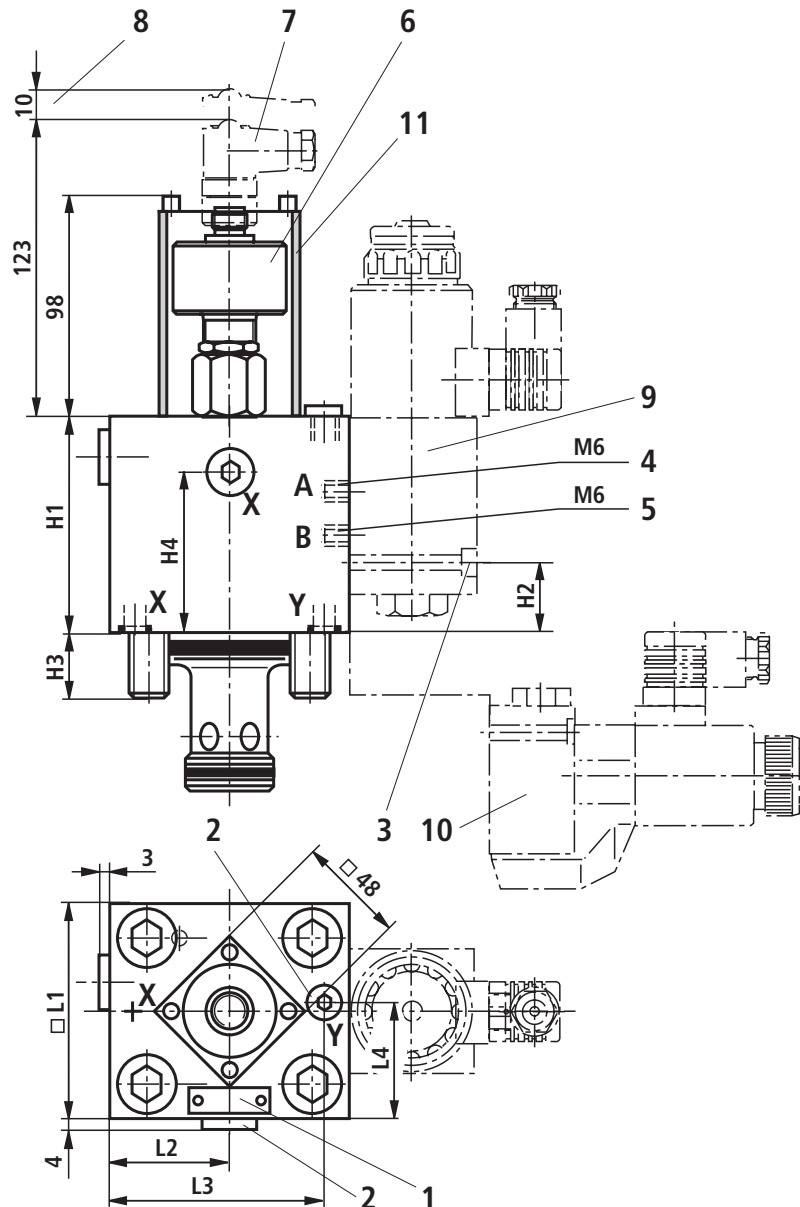

| Size | 40 | 50 |
|------|------|-----|
| H1 | 110 | 120 |
| H2 | 58.5 | 68 |
| H3 | 32 | 34 |
| H4 | 77.5 | 87 |
| □ L1 | 125 | 140 |
| L2 | 62.5 | 70 |
| L3 | 98.5 | 113 |
| L4 | 66.5 | 70 |

- | | |
|--|---|
| <ul style="list-style-type: none"> 1 Nameplate 2 Ports X and Y optionally as threaded connection G1/4 3 Valve fixing screws are included in the control cover's scope of supply 4 Plug screw M6 for ..EWB... 5 Plug screw M6 for ..EWA... | <ul style="list-style-type: none"> 6 Position switch type QM (included in type, see page 66) 7 Cable socket Z24 (separate order, see page 66) 8 Space required to remove cable socket 9 Directional spool valve type 4WE 6 D... 10 Directional poppet valve type M-3SEW 6 ... 11 Protective cap |
|--|---|

Control cover with electrical monitor of the closed position for mounting a directional spool or poppet valve: Type ..EWA..., ..EWB... (monitoring of the closed position)

Size 63

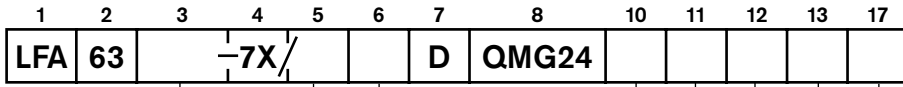

| Type |
|------|
| EWA |
| EWB |

| Area ratio A1: A2 |
|---------------------------|
| CA = 2:1 ¹⁾ |
| CB = 14.3:1 ²⁾ |

| Cracking pressure $p_{\bar{o}}$ |
|---------------------------------|
| 10 = 1.0 bar |
| 20 = 2.0 bar |
| 40 = 4.0 bar |

| Nozzle in channel (Ø in 1/10 mm) | | | |
|----------------------------------|-----|-----|-----|
| A | B | P | T |
| A** | | P** | T** |
| | B** | P** | T** |

No code = NBR seals
 V = FKM seals
 (Other seals on enquiry)
⚠ Caution!
 Observe compatibility of seals with hydraulic fluid used!

⚠ Nozzle possible; indicate, if required

QM = Inductive position switch, see page 66

G24 = 24 V DC voltage

For ordering codes for nozzles, see page 14 and 15.

¹⁾ Annulus area = 50% (standard version)

²⁾ Annulus area = 7%

M-3SEW 10 C../420...

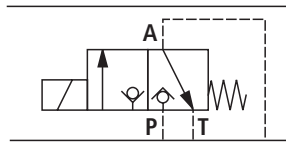

**M-3SED 10 UK../350...
M-3SEW 10 U../420...**

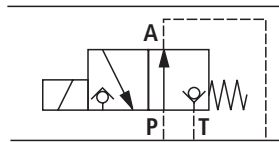

LFA 63 EWA...

(with directional spool valve type 4WE 10 D...)

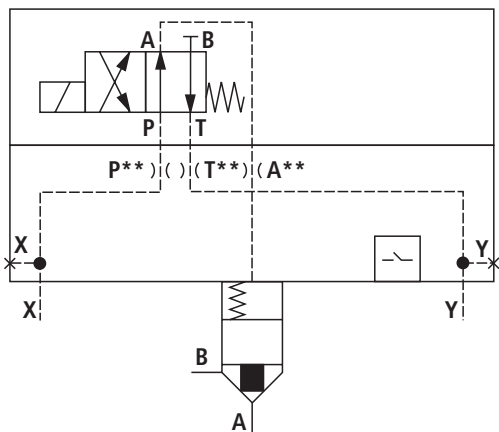

LFA 63 EWB...

(with directional spool valve type 4WE 10 D...)

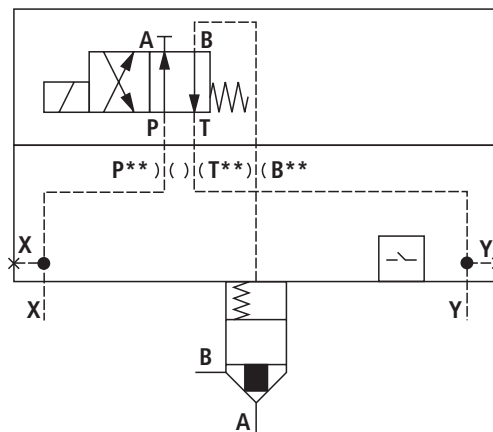

Control cover with electrical monitor of the closed position for mounting a directional spool or poppet valve: Type ..EWA..., ..EWB... (monitoring of the closed position) (nominal dimensions in mm)

Size 63

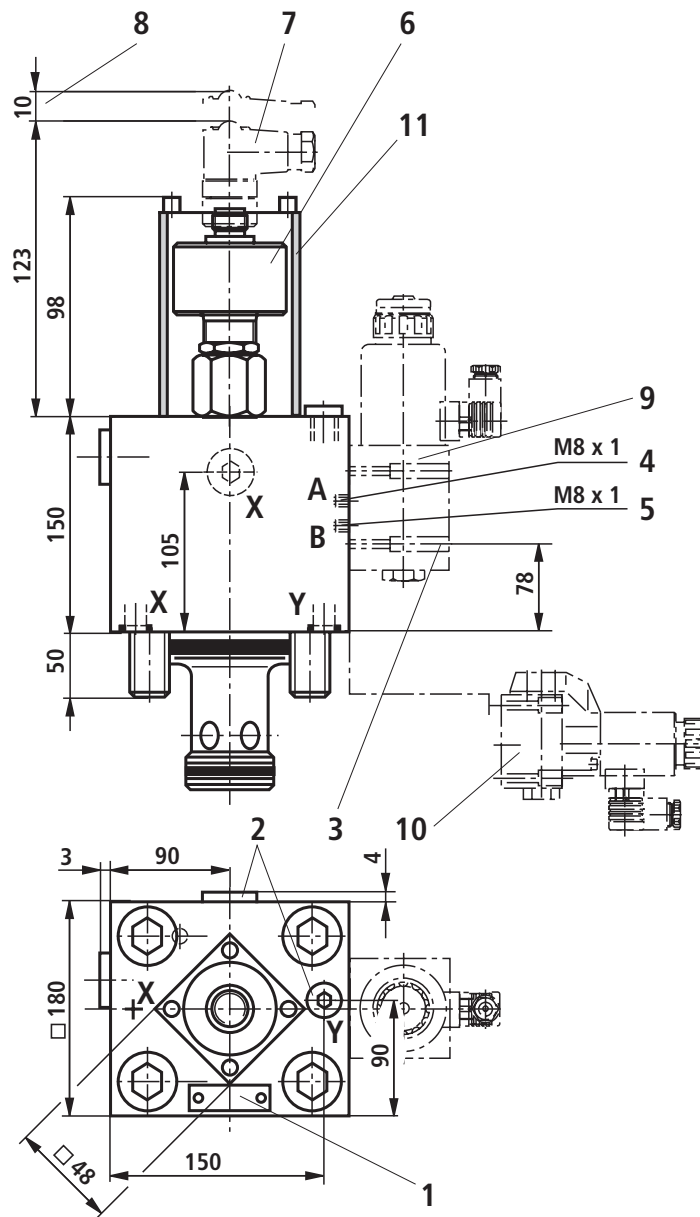

- | | |
|---|--|
| 1 Nameplate | 7 Cable socket Z24 (separate order, see page 66) |
| 2 Ports X and Y optionally as threaded connection G1/2 | 8 Space required to remove cable socket |
| 3 Valve fixing screws are included in the control cover's scope of supply | 9 Directional spool valve type 4WE 10 D... |
| 4 Plug screw M8 x 1 for ..EWB... | 10 Directional poppet valve type M-3SEW 10 ... |
| 5 Plug screw M8 x 1 for ..EWA... | 11 Protective cap |
| 6 Position switch type QM (included in type, see page 66) | |

Inductive position switch type QM, electrical connection

The electrical connection is made by means of a 4-pin cable socket with threaded connection M12 x 1.

The cable socket must be ordered separately (see below).

Operating voltage 24 V DC voltage + 20 %
- 10 %
(Residual ripple content < 10%)

Current consumption: Maximum 40 mA

Load-carrying capacity of outputs : 400 mA (output to PNP 24 V ⇒)

Temperature range: -20° C to +80° C

Pin assignment:

- 1: +24V
- 2: Normally-closed (low-resistance-high-resistance)
- 3: 0 V
- 4: Normally-open (high-resistance-low-resistance)

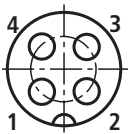

Plug-in contacts on position switch

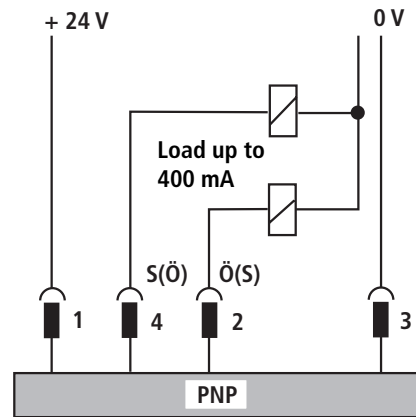

Inductive position switch type QM can be a normally-closed or normally-open contact.

⚠ Caution!

The position switch is not provided with a protective conductor connection!

Cable socket for inductive position switch type QM, separate order (nominal dimensions in mm)

Cable socket Z24, 4-pin, M12 x 1 with threaded connection, cable gland Pg 9.

Material no. **R900031155**

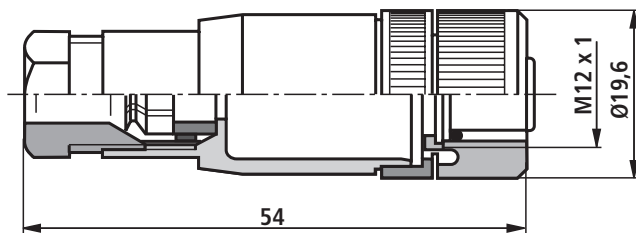

Cable socket Z24-3m, 4-pin, M12 x 1 with moulded-on PVC cable, 3m long.

Cable cross-section: 4 x 0.34 mm²

Wire identification:

- 1: brown
- 2: white
- 3: blue
- 4: black

Material no. **R900064381**

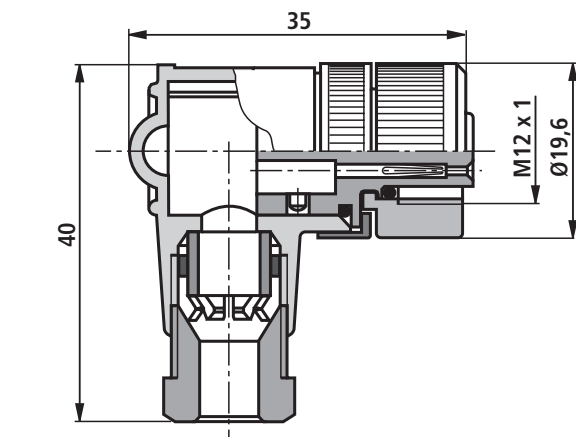
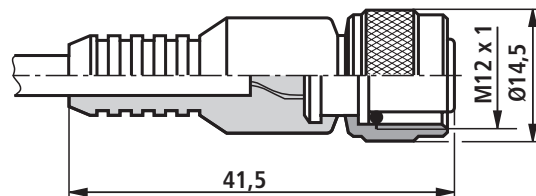

Cable socket Z24 – angled, 4-pin, M12 x 1 with threaded connection, cable gland Pg 9, angled.

Housing can be rotated through 4 x 90° in relation to the contact insert.

Material no. **R900082899**

Notes

Notes

Bosch Rexroth AG
Hydraulics
Zum Eisengießer 1
97816 Lohr am Main, Germany
Phone +49 (0) 93 52 / 18-0
Fax +49 (0) 93 52 / 18-23 58
documentation@boschrexroth.de
www.boschrexroth.de

© This document, as well as the data, specifications and other information set forth in it, are the exclusive property of Bosch Rexroth AG. Without their consent it may not be reproduced or given to third parties.

The data specified above only serve to describe the product. No statements concerning a certain condition or suitability for a certain application can be derived from our information. The given information does not release the user from the obligation of own judgement and verification. It must be remembered that our products are subject to a natural process of wear and aging.