

## Montageanleitung für original:

Pullbloc® · Pullbloc® 3.0 · Pullbloc® 4.1  
 Slidebloc® · Slidebloc® 3.0 · Slidebloc® 4.1  
 Slidebloc® light



### Kugellager- und Gleitlagertechniken Made in Germany!

Montage nur von Fachpersonal durchführen lassen.  
 Zur fachgerechten Montage Bohrlehre verwenden. (scoop Artikel 000133).  
 Die Garnituren sind wartungsfrei, geprüft und zertifiziert.

- Bohrlehre senkrecht ausrichten.  
**! Achtung !** Löcher  $\varnothing$  7,5 mm von beiden Seiten präzise bohren.  
**Nicht durchbohren, ansonsten kann das Schloss beschädigt werden!**
- Den Vierkant in das Türschloss zentriert einsetzen, so dass die dünne Seite der exzentrischen Bohrung zur Madenschraube des jeweiligen Drückers gerichtet ist.

- ! Achtung !** Bei Unterkonstruktionen LINKS und RECHTS beachten, beidseitig über den Vierkant pressen. Zusammenpressen bis die Stütznocken in die gebohrten Löcher eingreifen. Die Unterkonstruktionen miteinander verschrauben.  
**! Achtung !** Bitte beachten Sie, dass nicht jeder Türtyp im Schlossbereich gleich stabil ist. Die Schrauben dem Türtyp entsprechend festschrauben.

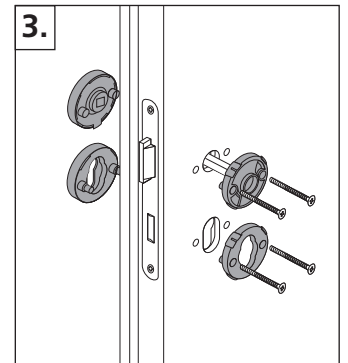
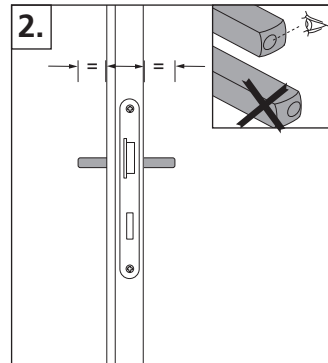
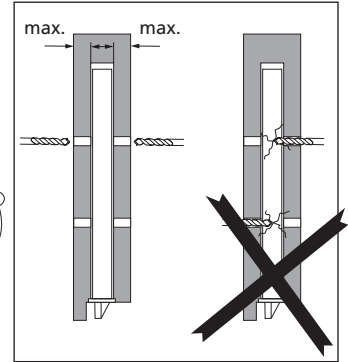
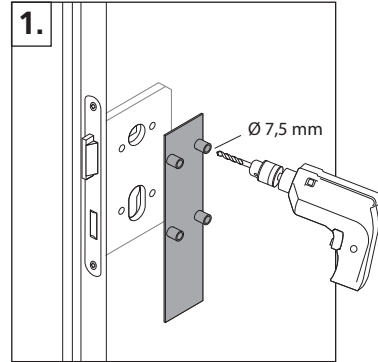
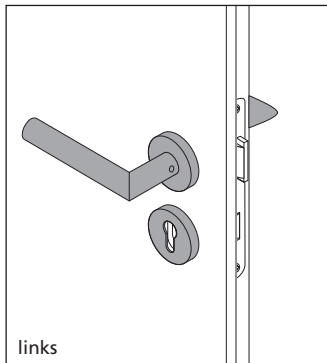
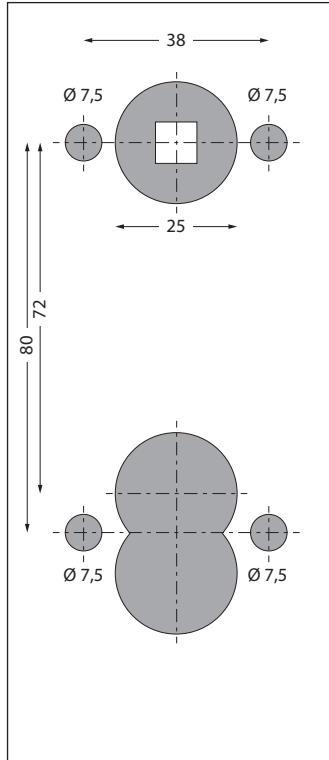
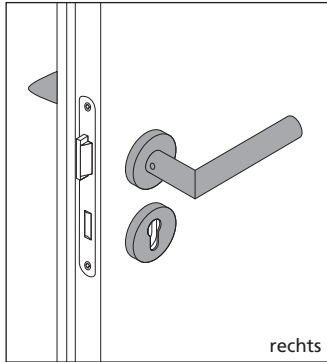

- ! Achtung ! Ganz wichtig!!**  
 Zuerst die Deckrosette aufklippen (Verdrehsicherung beachten!) und erst danach die Drücker aufsetzen, zusammenpressen, die Madenschrauben fest anziehen.

Zur Demontage beide Madenschrauben lösen und Drücker abziehen. Mit Hilfe eines Rosettenhebers die Deckrosetten von den Unterkonstruktionen abklippen.

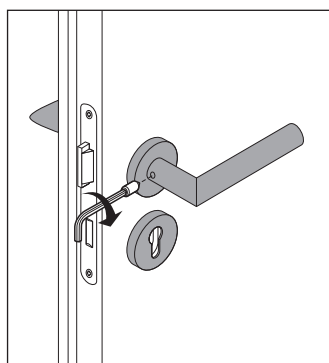
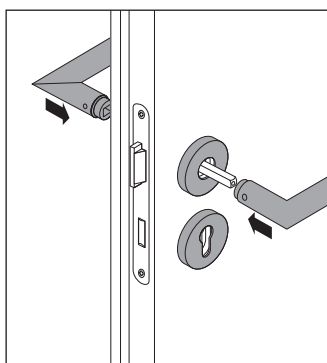
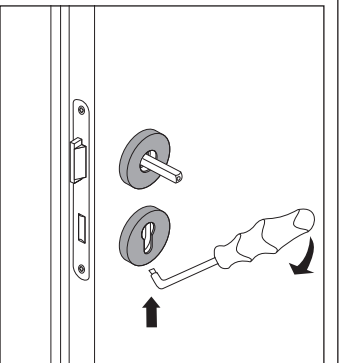
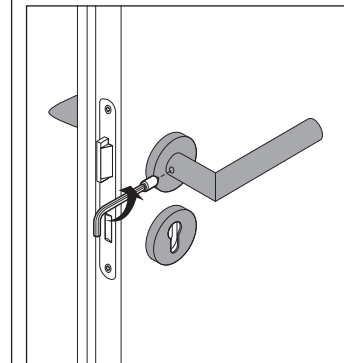
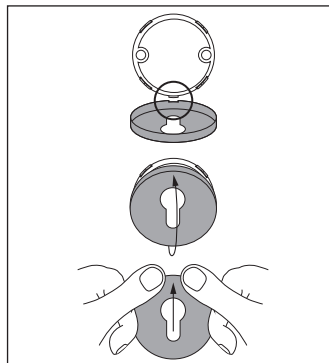
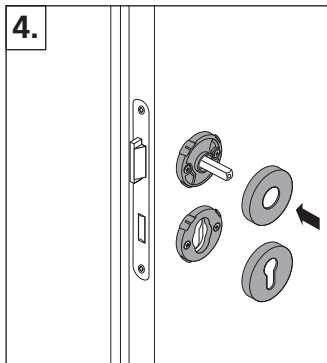

**Assembly instruction for original:**

Pullbloc® · Pullbloc® 3.0 · Pullbloc® 4.1  
 Slidebloc® · Slidebloc® 3.0 · Slidebloc® 4.1  
 Slidebloc® light



**Ball bearing- and slide bearing systems  
 Made in Germany!**

**Assembly by professionals only!**

Use a drilling template for competent installation. (scoop article 000133)  
 The door handles are maintenance-free, tested and certified.

1. Align drilling template vertically.  
**! Attention !** Drill holes  $\varnothing$  7,5 mm from each side precisely.  
**Don't drill through to avoid damaging the mortise lock!**
2. Insert the spindle into the mortise lock, with the thin side of the eccentric drillhole facing the thread holes of the handles.

**3. ! Attention!** Follow **LEFT** and **RIGHT** sides of bases, press both bases onto the spindle. Press tight until the supporting cams counter-sink into the drilled holes. Screw the bases together.  
**! Attention!** Please note that not every door type in the lock area is equally stable. Tighten screws according to door type.

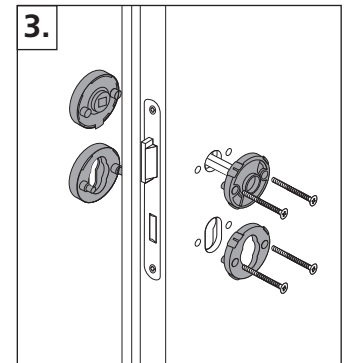
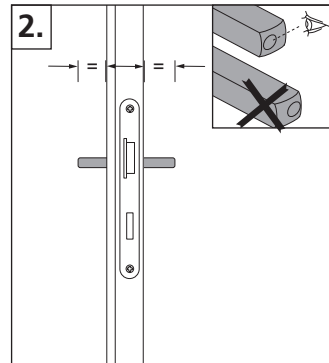
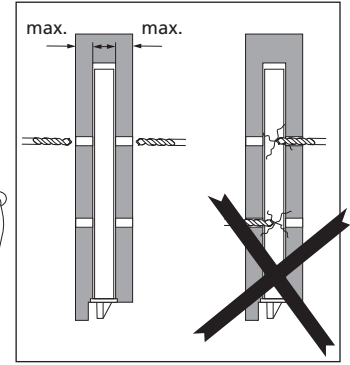
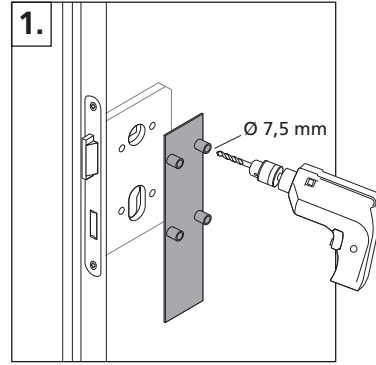
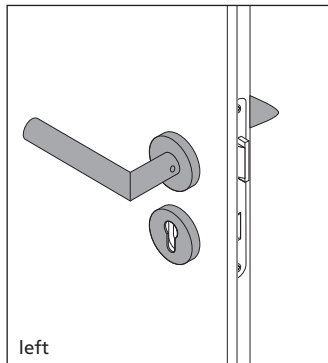
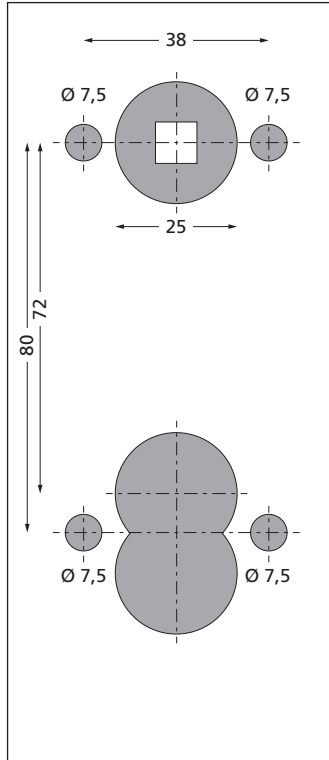
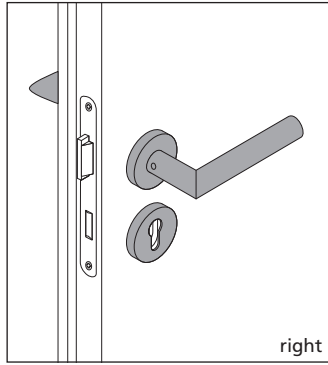

**4. ! Attention !** The first step is to clip on the covering rosette (follow fixing position gap) and then attach the handles, press them together firmly and tighten the grub screws firmly.

To dismantle, loosen both grub screws and remove handles. Using a rosette lifter, unclip the covering rosettes from the bases.

