



## NH fuse-switch 1p box terminal 35 - 150 mm<sup>2</sup>; mounting plate; NH1

**Part no.** XNH1-1-A250-BT  
**Catalog No.** 183050

### Delivery program

Basic function			Basic device
Number of poles			3 pole
Mounting type			Busbars of 60 mm
Size			1
Type of connection			Box terminal
Rated operational current	$I_e$	A	250
Front degree of protection (XNH installed)			IP20 (Operating status) IP2XC (Contact protection) IP10 (Handle cover open)
Rated operational voltage	$U_e$	V AC	690
Rated operational voltage	$U_e$	V DC	440
Rated conditional short-circuit current		kA	120 (500 V) 100 (690 V)
Flammability characteristics			Self-extinguishing as per UL 94
Description			Current paths of electrolytic copper, silver-plated

### Technical data

#### Electrical

Standards			IEC/EN 60947-3
Rated operational voltage	$U_e$	V AC	690
Rated operational voltage	$U_e$	V DC	440
Rated operational current	$I_e$	A	250
Rated frequency	f	Hz	40 - 60
Rated insulation voltage	$U_i$	V AC	800
Total heat dissipation at $I_{th}$ (without fuses)	$P_v$	W	22
Heat dissipation at 80% (without fuses)	$P_v$	W	14.1
Rated impulse withstand voltage	$U_{imp}$	kV	8
Utilization category AC-23B			
Rated operating voltage	$U_e$	V AC	400
Rated operating current	$I_e$	A	250
Utilization category AC22B			
Rated operating voltage	$U_e$	V AC	500
Rated operating current	$I_e$	A	250
Utilization category AC-21B			
Rated operating voltage	$U_e$	V AC	690
Rated operating current	$I_e$	A	250
Utilization category DC-22B			
Rated operating voltage	$U_e$	V DC	DC values on request
Rated operating current	$I_e$	A	DC values on request

Utilization category DC21B			
Rated operating voltage	U <sub>e</sub>	V DC	DC values on request
Rated operating current	I <sub>e</sub>	A	DC values on request
Rated conditional short-circuit current		kA	120 (500 V) 100 (690 V)
Rated short-time withstand current	I <sub>cw</sub>	kA	10
Max. fuse			
Size according to DIN VDE 0636-2			1
Max. permitted power loss per fuse link	P <sub>v</sub>	W	23
Lifespan, electrical	Operations		200

## Mechanical

Front degree of protection (XNH installed)			IP20 (Operating status) IP2XC (Contact protection) IP10 (Handle cover open)
Ambient temperature		°C	-25 - +55
Rated operating mode			Permanent operation
Activation			Dependent manual activation
Mounting position			Vertical, horizontal
Altitude		m	Max. 2000
Overvoltage category/pollution degree			III/3
RoHS (in accordance with Directive 2002/95/EC of the European Parliament and Council)			Yes
Direction of incoming supply			as required
Lockable			Yes, optional
Sealable			Yes, Standard
Material characteristics			
Material			Polyamide
Colour			Grey
Flammability characteristics			Self-extinguishing as per UL 94
Halogen-free			Yes
Voltage test			Yes, sliding inspection windows
Lifespan, mechanical	Operations		1400
Track resistance			CTI 600
Heat deflection temperature		?C	125

## Terminal capacity

Flange connection			
Bolt diameter			M10
Cable lug max. width		mm	37
Flat busbar		mm	30 x 10
Box terminal			
Stranded		mm <sup>2</sup>	35 - 150 Cu/Al
Copper strip	Number of segments x width x thickness	mm	10 x 16 x 0,8
Box terminal			
Stranded		mm <sup>2</sup>	25 - 150 Cu
Copper band	Number of segments x width x thickness	mm	6 x 16 x 0,8
Clamp-type terminal			
1-hole		mm <sup>2</sup>	10 - 150 Cu/Al
Double clamp-type terminal			
Stranded		mm <sup>2</sup>	2x (70 - 95) Cu/Al

## Design verification as per IEC/EN 61439

Technical data for design verification			
Rated operational current for specified heat dissipation	I <sub>n</sub>	A	250

Heat dissipation per pole, current-dependent	P <sub>vid</sub>	W	5.3
Equipment heat dissipation, current-dependent	P <sub>vid</sub>	W	16
IEC/EN 61439 design verification			
10.2 Strength of materials and parts			
10.2.2 Corrosion resistance			Meets the product standard's requirements.
10.2.3.1 Verification of thermal stability of enclosures			Meets the product standard's requirements.
10.2.3.2 Verification of resistance of insulating materials to normal heat			Meets the product standard's requirements.
10.2.3.3 Verification of resistance of insulating materials to abnormal heat and fire due to internal electric effects			Meets the product standard's requirements.
10.2.4 Resistance to ultra-violet (UV) radiation			Meets the product standard's requirements.
10.2.5 Lifting			Does not apply, since the entire switchgear needs to be evaluated.
10.2.6 Mechanical impact			Does not apply, since the entire switchgear needs to be evaluated.
10.2.7 Inscriptions			Meets the product standard's requirements.
10.3 Degree of protection of ASSEMBLIES			Does not apply, since the entire switchgear needs to be evaluated.
10.4 Clearances and creepage distances			Is the panel builder's responsibility.
10.5 Protection against electric shock			Does not apply, since the entire switchgear needs to be evaluated.
10.6 Incorporation of switching devices and components			Does not apply, since the entire switchgear needs to be evaluated.
10.7 Internal electrical circuits and connections			Is the panel builder's responsibility.
10.8 Connections for external conductors			Is the panel builder's responsibility.
10.9 Insulation properties			
10.9.2 Power-frequency electric strength			U <sub>i</sub> = 800 V AC
10.9.3 Impulse withstand voltage			Is the panel builder's responsibility.
10.9.4 Testing of enclosures made of insulating material			Is the panel builder's responsibility.
10.10 Temperature rise			The panel builder is responsible for the temperature rise calculation. Eaton will provide heat dissipation data for the devices.
10.11 Short-circuit rating			Is the panel builder's responsibility. The specifications for the switchgear must be observed.
10.12 Electromagnetic compatibility			Is the panel builder's responsibility. The specifications for the switchgear must be observed.
10.13 Mechanical function			The device meets the requirements, provided the information in the instruction leaflet (IL) is observed.

## Technical data ETIM 6.0

Low-voltage industrial components (EG000017) / Fuse switch disconnecter (EC001040)			
Electric engineering, automation, process control engineering / Low-voltage switch technology / Off-load switch, circuit breaker, control switch / Fuse switch disconnecter (ec1@ss8.1-27-37-14-01 [AKF058010])			
Version as main switch			No
Version as safety switch			No
Max. rated operation voltage U <sub>e</sub> AC		V	690
Rated permanent current I <sub>u</sub>		A	250
Rated operation power at AC-23, 400 V		kW	0
Conditioned rated short-circuit current I <sub>q</sub>		kA	120
Rated short-time withstand current I <sub>cw</sub>		kA	6
Suitable for fuses			NH1
Number of poles			1
With error protection			No
Type of electrical connection of main circuit			Frame clamp
Suitable for ground mounting			Yes
Suitable for front mounting 4-hole			No
Suitable for busbar mounting			No
Type of control element			Cover grip
Position control element			Front side
Motor drive optional			No
Motor drive integrated			No
Version as emergency stop installation			No
Degree of protection (IP), front side			-

## Dimensions

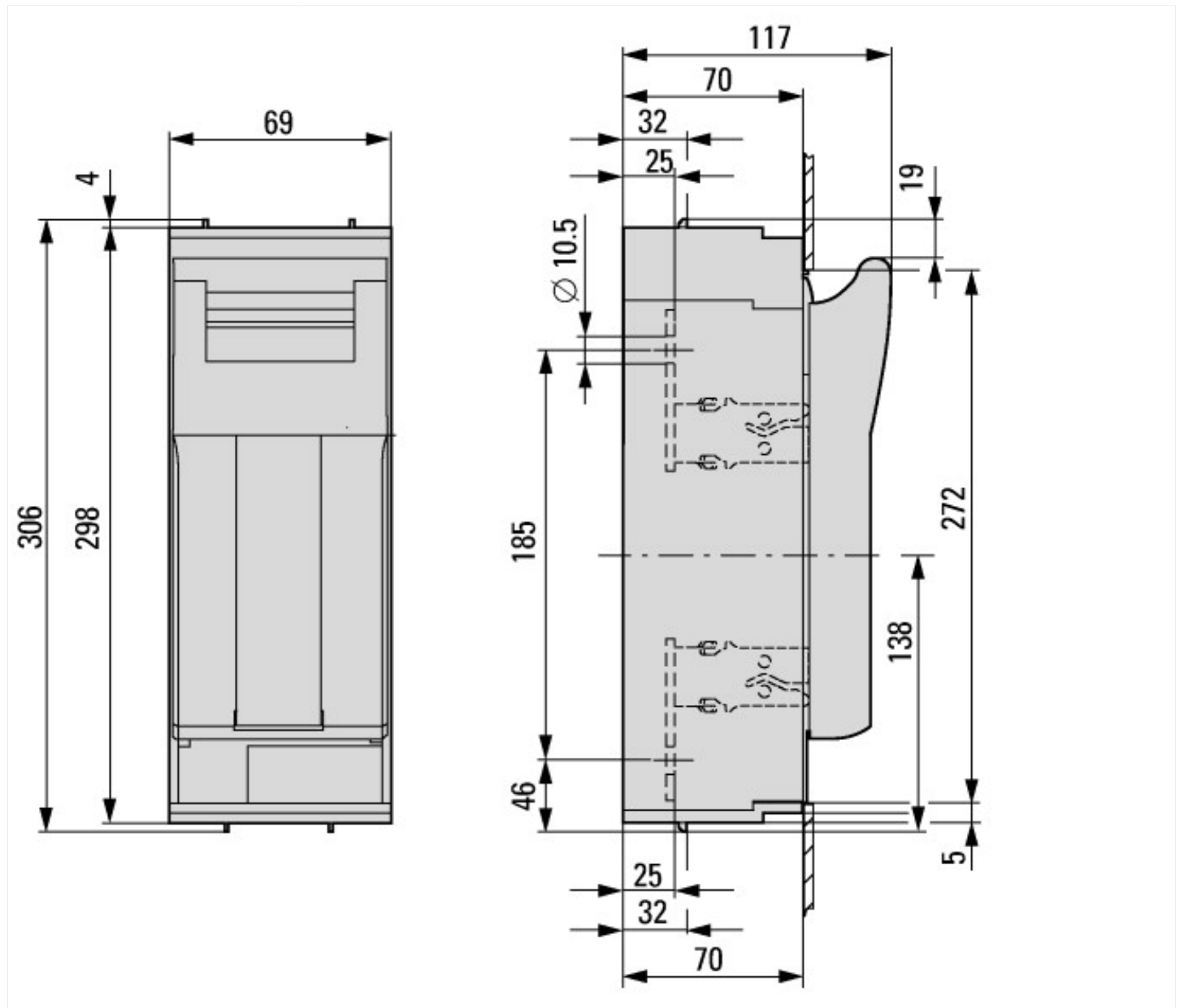

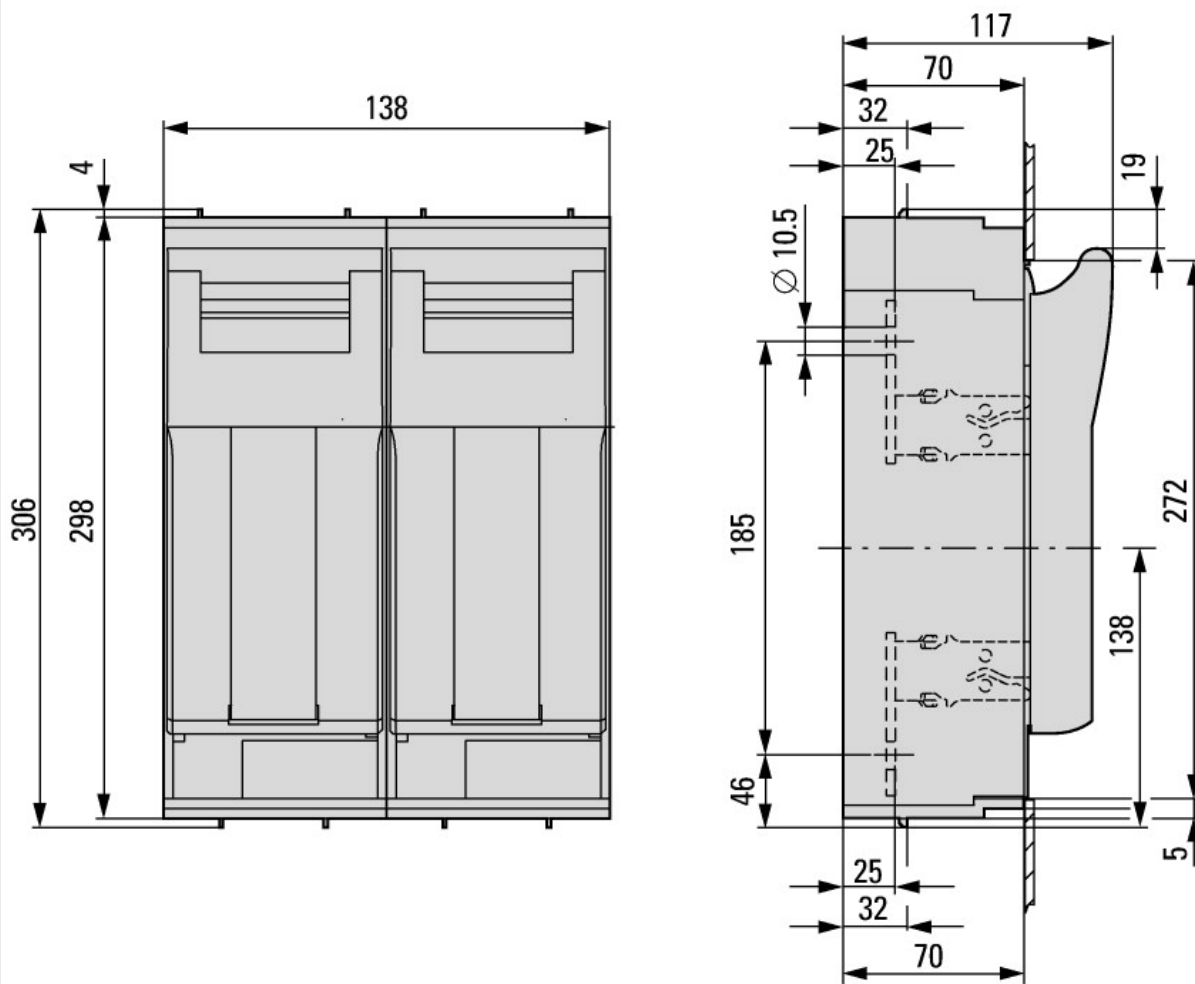

2x XNH1-1-A...

### Additional product information (links)

**IL0131119ZU Fuse switch-disconnector XNH**

IL0131119ZU Fuse switch-disconnector XNH [ftp://ftp.moeller.net/DOCUMENTATION/AWA\\_INSTRUCTIONS/IL0131119ZU2017\\_02.pdf](ftp://ftp.moeller.net/DOCUMENTATION/AWA_INSTRUCTIONS/IL0131119ZU2017_02.pdf)